

# AXEL Platine Terminal

AX3000 Models 65, 70, 75, 80 and 85

## *USER'S MANUAL*

April 2011 - Ref.: AX3E/0826-5

The reproduction of this material, in part or whole, is strictly prohibited. For additional information, please contact:

**AXEL**

14 Avenue du Québec  
Bât. K2 EVOLIC - BP 728  
91962 Courtabœuf cedex - FRANCE  
Tel.: 33 1.69.28.27.27  
Fax: 33 1.69.28.82.04  
Email: [info@axel.com](mailto:info@axel.com)

The information related to firmware 0826f in this document is subject to change without notice. AXEL assumes no responsibility for any errors that may appear in this document.

All trademarks and registered trademarks are the property of their respective holders.

© - 2009-2011 - AXEL - All Rights Reserved.

## TABLE OF CONTENT

|                                                                  |           |
|------------------------------------------------------------------|-----------|
| <b>INTRODUCTION .....</b>                                        | <b>1</b>  |
| <b>1 - INTRODUCTION TO THE AX3000 .....</b>                      | <b>5</b>  |
| 1.1 - TERMINAL MODELS.....                                       | 6         |
| 1.2 - MAIN FUNCTIONS .....                                       | 7         |
| 1.2.1 - Network Functions.....                                   | 7         |
| 1.2.2 - Terminal Function.....                                   | 7         |
| 1.2.3 - Print and Terminal Server.....                           | 7         |
| 1.2.4 - Tools and Statistics.....                                | 8         |
| <b>2 - INITIAL POWER-ON .....</b>                                | <b>9</b>  |
| 2.1 - QUICK SET-UP .....                                         | 10        |
| 2.1.1 - First Screen .....                                       | 12        |
| 2.1.2 - Network Connection .....                                 | 13        |
| 2.1.3 - Devices.....                                             | 14        |
| 2.1.4 - Citrix Published Application Desktop.....                | 15        |
| 2.1.5 - Citrix (Published Application or Published Server) ..... | 16        |
| 2.1.6 - Serial Connection .....                                  | 16        |
| 2.1.7 - Set-Up Summary.....                                      | 18        |
| 2.2 - AUTO-CONFIGURATION .....                                   | 18        |
| 2.2.1 - Stage 1: Checking the Network .....                      | 19        |
| 2.2.2 - Stage 2: Sending DHCP requests .....                     | 19        |
| 2.2.3 - Stage 3: Sending requests to AxRM.....                   | 20        |
| 2.2.4 - Stage 4: Receiving the firmware download .....           | 21        |
| 2.2.5 - Stage 5: Receiving the configuration file .....          | 22        |
| <b>3 - INTERACTIVE SET-UP.....</b>                               | <b>25</b> |
| 3.1 - SETTING NETWORK ENVIRONMENT .....                          | 27        |
| 3.1.1 - General Parameters .....                                 | 28        |
| 3.1.2 - Ethernet Interface .....                                 | 29        |
| 3.1.3 - Server Management .....                                  | 33        |
| 3.2 - GENERAL SETTINGS.....                                      | 35        |
| 3.2.1 - The Keyboard and the Mouse .....                         | 35        |
| 3.2.2 - The Screen .....                                         | 36        |
| 3.2.3 - Audio.....                                               | 40        |
| 3.2.4 - Global RDP/ICA.....                                      | 41        |
| 3.2.5 - Time Settings.....                                       | 42        |

|                                                                             |           |
|-----------------------------------------------------------------------------|-----------|
| 3.2.6 - Terminal Remote Control.....                                        | 45        |
| 3.2.7 - Password.....                                                       | 46        |
| 3.2.8 - Miscellaneous.....                                                  | 47        |
| 3.3 - SETTING EACH SESSION.....                                             | 48        |
| 3.3.1 - "TSE (rdp)" or "Citrix (Ica)", "Virtual Desktop" Session Types..... | 49        |
| 3.3.2 - "VNC" Session Type.....                                             | 49        |
| 3.3.3 - "5250" Session Type.....                                            | 49        |
| 3.3.4 - "3270" Session Type.....                                            | 50        |
| 3.3.5 - "Text Emulation" Session Type.....                                  | 50        |
| 3.3.6 - "None" Session Type.....                                            | 50        |
| 3.3.7 - Duplicating Session Settings.....                                   | 50        |
| 3.4 - USB MANAGEMENT.....                                                   | 50        |
| 3.4.1 - Specifications.....                                                 | 50        |
| 3.4.2 - Connecting a USB Keyboard.....                                      | 51        |
| 3.4.3 - Connecting a USB Barcode Reader.....                                | 52        |
| 3.4.4 - Connecting a Mouse.....                                             | 52        |
| 3.4.5 - Connecting a HUB.....                                               | 52        |
| 3.4.6 - Connecting a Printer.....                                           | 52        |
| 3.4.7 - Connecting a USB-RS232 Adaptor.....                                 | 54        |
| 3.4.8 - Connecting a Touch Screen.....                                      | 55        |
| 3.4.9 - Connecting a Mass Storage Device.....                               | 55        |
| 3.4.10 - Connecting a Smartcard Reader.....                                 | 57        |
| 3.4.11 - Connecting a USB Audio Device.....                                 | 58        |
| 3.4.12 - Listing Connected USB Devices.....                                 | 58        |
| 3.5 - SETTING AUXILIARY AND LOGICAL PORTS.....                              | 59        |
| 3.5.1 - Setting Up the Ports.....                                           | 59        |
| 3.5.2 - Connecting a Printer.....                                           | 63        |
| 3.5.3 - Connecting a Serial Terminal.....                                   | 65        |
| 3.5.4 - Connecting other Peripherals.....                                   | 66        |
| 3.5.5 - Using a Serial Port as the Main Port of a Session.....              | 66        |
| 3.5.6 - Other Uses.....                                                     | 67        |
| 3.6 - TERMINAL LOCAL DESKTOP.....                                           | 68        |
| 3.6.1 - Session Manager.....                                                | 69        |
| 3.6.2 - Status Line.....                                                    | 69        |
| 3.6.3 - Multi-Session Keystroke.....                                        | 70        |
| 3.7 - OTHER FUNCTIONS.....                                                  | 71        |
| 3.7.1 - Tuning.....                                                         | 71        |
| 3.7.2 - Auto-Configuration.....                                             | 71        |
| 3.7.3 - Factory Settings.....                                               | 72        |
| 3.7.4 - License Store.....                                                  | 72        |
| 3.7.5 - Smartcard Readers.....                                              | 72        |
| <b>4 - USING THE AX3000.....</b>                                            | <b>73</b> |

|                                                                          |           |
|--------------------------------------------------------------------------|-----------|
| 4.1 - SWITCHING ON THE AX3000.....                                       | 74        |
| 4.1.1 - Session Manager: Classic Mode .....                              | 75        |
| 4.1.2 - Session Manager: Desktop Mode.....                               | 76        |
| 4.2 - USING MULTIPLE SESSIONS.....                                       | 77        |
| 4.2.1 - Opening and Switching Sessions .....                             | 77        |
| 4.2.2 - Disconnecting Sessions.....                                      | 78        |
| 4.3 - LOCKING THE SCREEN.....                                            | 78        |
| 4.4 - "COPY/PASTE" FUNCTION.....                                         | 79        |
| 4.5 - TURNING OFF THE AX3000 .....                                       | 80        |
| 4.6 - AX3000 HOT-KEYS.....                                               | 82        |
| <b>5 - INSTALLING UNDER WINDOWS .....</b>                                | <b>83</b> |
| 5.1 - RDP SCREEN SESSION.....                                            | 84        |
| 5.1.1 - Setting-Up an RDP Session .....                                  | 85        |
| 5.1.2 - Display Parameters .....                                         | 86        |
| 5.1.3 - RDP Additional Parameters.....                                   | 86        |
| 5.1.4 - Automatic Logon and Auto-Run.....                                | 88        |
| 5.1.5 - Redirected Resources .....                                       | 89        |
| 5.1.6 - Bandwidth .....                                                  | 94        |
| 5.1.7 - Connection Properties .....                                      | 95        |
| 5.2 - ICA SCREEN SESSION .....                                           | 96        |
| 5.2.1 - Setting-Up an ICA Session.....                                   | 96        |
| 5.2.2 - Connection Types and ICA Browser Settings .....                  | 97        |
| 5.2.3 - Display Parameters .....                                         | 100       |
| 5.2.4 - ICA Additional Parameters .....                                  | 100       |
| 5.2.5 - Automatic Logon and Auto-Run.....                                | 101       |
| 5.2.6 - Redirected Resources .....                                       | 102       |
| 5.2.7 - Bandwidth .....                                                  | 107       |
| 5.2.8 - Connection Properties .....                                      | 108       |
| 5.3 - CITRIX "PUBLISHED APP. DESKTOP" SESSION .....                      | 108       |
| 5.3.1 - General Configuration of the Published App. Desktop session..... | 108       |
| 5.3.2 - Desktop Parameters.....                                          | 112       |
| 5.3.3 - Using the "Published App. Desktop".....                          | 113       |
| 5.4 - VIRTUAL DESKTOP SESSION.....                                       | 116       |
| 5.4.1 - Setting-Up an Virtual Desktop Session.....                       | 116       |
| 5.4.2 - Connection Type and Browser Settings .....                       | 117       |
| 5.4.3 - Available Desktop Menu .....                                     | 118       |
| 5.4.4 - Automatic Logon.....                                             | 119       |
| 5.4.5 - Using the "Virtual Desktop" Session.....                         | 120       |
| 5.4.6 - Configuring the VDM Connection Broker.....                       | 120       |
| 5.5 - CONFIGURING THE WINDOWS SERVER (ICA/RDP) .....                     | 122       |
| 5.5.1 - Encryption Level .....                                           | 123       |

|                                                         |            |
|---------------------------------------------------------|------------|
| 5.5.2 - Automatic Logon .....                           | 125        |
| 5.5.3 - Idle Session Limit.....                         | 126        |
| 5.5.4 - Desktop Background with Windows 2003 .....      | 127        |
| 5.5.5 - Allowing Blank Passwords with Windows 2003..... | 128        |
| 5.5.6 - Time Zone Redirection.....                      | 128        |
| 5.5.7 - Closing Phantom Sessions .....                  | 129        |
| 5.6 - USING THE AX3000 .....                            | 130        |
| 5.6.1 - Opening a Windows Session.....                  | 130        |
| 5.6.2 - Information about a Windows Session .....       | 130        |
| 5.6.3 - Closing a Windows Session .....                 | 131        |
| 5.6.4 Turning-Off the AX3000.....                       | 132        |
| 5.6.5 - In Event of Connection Problems .....           | 132        |
| 5.7 - MANAGING PRINTERS .....                           | 133        |
| 5.7.1 - Setting-Up the AX3000.....                      | 134        |
| 5.7.2 - Setting-Up the Windows Server.....              | 135        |
| 5.8 - PUBLISHING APPLICATIONS .....                     | 135        |
| 5.9 - REMOTE ADMINISTRATION.....                        | 136        |
| 5.9.1 - Remote Control.....                             | 136        |
| 5.9.2 - The Axel Remote Management Software (AxRM)..... | 137        |
| <b>6 - INSTALLING UNDER OS/400.....</b>                 | <b>139</b> |
| 6.1 - 5250 SCREEN SESSION .....                         | 140        |
| 6.1.1 - Keyboard Type .....                             | 140        |
| 6.1.2 - Setting a Session.....                          | 141        |
| 6.1.3 - Display Parameters .....                        | 142        |
| 6.1.4 - Customizing 5250 Emulation .....                | 143        |
| 6.1.5 - Setting-Up the Auto-Signon Function .....       | 148        |
| 6.1.6 - Connection Properties .....                     | 149        |
| 6.2 - USING THE AX3000.....                             | 149        |
| 6.2.1 - The 5250 Status Line.....                       | 149        |
| 6.2.2 - Using the Keyboard .....                        | 151        |
| 6.2.3 - Programming Function Keys (Macro Feature).....  | 152        |
| 6.2.4 - The Mouse .....                                 | 154        |
| 6.2.5 - The Transparent Mode .....                      | 154        |
| 6.3 - 5250 PRINTER .....                                | 156        |
| 6.3.1 - Setting-Up and Using a PRT5250 Printer.....     | 157        |
| 6.3.2 - Setting-Up and Using an LPD Printer .....       | 161        |
| 6.4 - REMOTE ADMINISTRATION.....                        | 162        |
| 6.4.1 - Remote Control.....                             | 162        |
| 6.4.2 - Other Functions .....                           | 162        |
| 6.5 - FURTHER OPTIONS.....                              | 164        |
| 6.5.1 - Turning-Off the AX3000.....                     | 164        |

|                                                              |            |
|--------------------------------------------------------------|------------|
| 6.5.2 - Reconnection Problem .....                           | 165        |
| <b>7 - INSTALLING UNDER OS/390 .....</b>                     | <b>167</b> |
| 7.1 - 3270 SCREEN SESSION .....                              | 168        |
| 7.1.1 - Setting a Session.....                               | 169        |
| 7.1.2 - Display Parameters .....                             | 170        |
| 7.1.3 - Customizing the 3270 Emulation .....                 | 170        |
| 7.1.4 - Connection Properties .....                          | 175        |
| 7.2 - USING THE TERMINAL.....                                | 176        |
| 7.2.1 - The 3270 Status Line.....                            | 176        |
| 7.2.2 - Using a PC/AT Keyboard (102/105 keys).....           | 177        |
| 7.2.3 - Programming Function Keys (Macro Feature) .....      | 178        |
| 7.3 - 3270 PRINTER .....                                     | 180        |
| 7.4 - REMOTE ADMINISTRATION.....                             | 182        |
| 7.4.1 - Remote Control.....                                  | 182        |
| 7.4.2 - Other Functions .....                                | 182        |
| <b>8 - INSTALLING UNDER UNIX/LINUX .....</b>                 | <b>183</b> |
| 8.1 - TEXT MODE SESSION (TCP/IP OR SERIAL MODE).....         | 184        |
| 8.1.1 - Setting a Session Profile.....                       | 184        |
| 8.1.2 - Protocols: telnet, tty, ssh, ssh2 or aux1/aux2 ..... | 185        |
| 8.1.3 - Selecting the Emulation .....                        | 188        |
| 8.1.4 - Display Parameters .....                             | 189        |
| 8.1.5 - Customizing the Emulation .....                      | 189        |
| 8.1.6 - Coloring Mode .....                                  | 196        |
| 8.1.7 - Underline Attribute Management .....                 | 199        |
| 8.1.8 - Connection Properties .....                          | 200        |
| 8.1.9 - Login Script.....                                    | 201        |
| 8.1.10 - The Multi-Shell.....                                | 202        |
| 8.2 - GRAPHICAL MODE SESSION (VNC).....                      | 205        |
| 8.2.1 - Setting-Up a VNC Session .....                       | 205        |
| 8.2.2 - Configuring VNC on the Unix/Linux Server .....       | 210        |
| 8.3 - CONTROLLING PRINTERS.....                              | 212        |
| 8.3.1 - The tty Protocol.....                                | 212        |
| 8.3.2 - The LPD Protocol .....                               | 213        |
| 8.3.3 - The rsh Command.....                                 | 215        |
| 8.3.4 - Using Transparent Mode .....                         | 215        |
| 8.4 - THE AXEL TTY SERVER .....                              | 216        |
| 8.4.1 - Overview.....                                        | 216        |
| 8.4.2 - Installing an AXEL tty server.....                   | 217        |
| 8.4.3 - Using an AXEL tty server.....                        | 218        |
| 8.4.4 - The axttyd Mechanism.....                            | 219        |

|                                                                    |            |
|--------------------------------------------------------------------|------------|
| 8.4.5 - Uninstalling .....                                         | 220        |
| 8.4.6 - In Event of Problems.....                                  | 220        |
| 8.5 - REMOTE ADMINISTRATION.....                                   | 220        |
| 8.5.1 - Remote Control.....                                        | 220        |
| 8.5.2 - Other Functions .....                                      | 220        |
| <b>9 - TOOLS AND STATISTICS .....</b>                              | <b>225</b> |
| 9.1 - THE PING COMMAND .....                                       | 226        |
| 9.2 - CONNECTION MANAGEMENT .....                                  | 226        |
| 9.2.1 - Global Connection List.....                                | 227        |
| 9.2.2 - "TCP Server" and "TCP Client" Connection Information ..... | 228        |
| 9.3 - ETHERNET INTERFACE INFORMATION .....                         | 230        |
| 9.3.1 - Status.....                                                | 230        |
| 9.3.2 - DHCP/DNS .....                                             | 231        |
| 9.3.3 - Statistic .....                                            | 232        |
| 9.4 - USB STATISTICS .....                                         | 233        |
| <b>10 - REMOTE ADMINISTRATION .....</b>                            | <b>235</b> |
| 10.1 - AXRM: THE AXEL MANAGEMENT SOFTWARE .....                    | 236        |
| 10.2 - REMOTE CONTROL.....                                         | 237        |
| 10.2.1 - Configuring.....                                          | 238        |
| 10.2.2 - Operation .....                                           | 238        |
| 10.3 - INTERACTIVE TELNET SET-UP .....                             | 238        |
| 10.4 - BATCH REMOTE SET-UP .....                                   | 239        |
| 10.4.1 - AX3000 Remote Set-Up .....                                | 239        |
| 10.4.2 - Obtaining a Configuration .....                           | 240        |
| 10.4.3 - Error Messages .....                                      | 241        |
| <b>APPENDIX .....</b>                                              | <b>247</b> |
| A.1 - USING THE INTERACTIVE SET-UP .....                           | 248        |
| A.1.1 - Entering the Set-Up.....                                   | 248        |
| A.1.2 - Navigation.....                                            | 249        |
| A.1.3 - Enter Data .....                                           | 250        |
| A.1.4 - Special Notation .....                                     | 251        |
| A.1.5 - Exiting the set-up.....                                    | 251        |
| A.2 - NETWORK OVERVIEW .....                                       | 252        |
| A.2.1 - Ethernet Addresses.....                                    | 252        |
| A.2.2 - IP Address.....                                            | 252        |
| A.2.3 - Router.....                                                | 253        |
| A.3 - THE DHCP PROTOCOL .....                                      | 255        |
| A.3.1 - Overview .....                                             | 256        |
| A.3.2 - Setting-Up the AX3000.....                                 | 256        |



|                                                                   |     |
|-------------------------------------------------------------------|-----|
| A.3.3 - Using the AX3000 .....                                    | 256 |
| A.3.4 - Errors.....                                               | 257 |
| A.4 - THE DNS PROTOCOL.....                                       | 258 |
| A.4.1 - Overview .....                                            | 259 |
| A.4.2 - Resolving a Name.....                                     | 260 |
| A.4.3 - Publishing the Terminal Name .....                        | 263 |
| A.5 - REMOTE SET-UP CONFIGURATION FILE FORMAT .....               | 265 |
| Header .....                                                      | 266 |
| Substitution Commands.....                                        | 266 |
| Ethernet Parameters.....                                          | 267 |
| TCP/IP Parameters.....                                            | 268 |
| Auxiliary Ports and Logical Ports Parameters.....                 | 269 |
| Terminal Parameters .....                                         | 276 |
| Multi-session Parameters .....                                    | 277 |
| Session Parameters.....                                           | 278 |
| End of File.....                                                  | 284 |
| A.6 - SETTING-UP AXEL DHCP OPTIONS .....                          | 284 |
| A.6.1 - Overview .....                                            | 284 |
| A.6.2 - Adding an Axel option with the Microsoft DHCP Server..... | 285 |
| A.6.3 - 'axrmserv' option: auto-configuration.....                | 286 |
| A.7 - SETTING THE IP ADDRESS BY A PING COMMAND .....              | 287 |
| A.8 - RSH ADMINISTRATION COMMAND LIST .....                       | 288 |
| A.9 - FIRMWARE DOWNLOADING (BOOTP AND TFTP).....                  | 289 |
| A.9.1 - Declaring and Enabling TFTP and BOOTP.....                | 290 |
| A.9.2 - Downloading by TFTP Protocol.....                         | 292 |
| A.9.3 - Downloading by BOOTP and TFTP Protocols .....             | 294 |
| A.9.4 - The Download Process .....                                | 296 |
| A.9.5 - In Event of difficulties .....                            | 297 |
| A.10 - MORE INFORMATION.....                                      | 299 |
| A.10.1 - Reload Factory Settings.....                             | 299 |
| A.10.2 - General Level: Advanced Parameters .....                 | 299 |
| A.10.3 - Session Level: Enhanced Parameters .....                 | 303 |
| A.10.4 - RDP/ICA Sessions: Microsoft Keyboard Codes.....          | 306 |
| A.10.5 - Displaying Text Session in Graphics Mode.....            | 308 |
| A.11 - HARDWARE AND FIRMWARE INFORMATION .....                    | 312 |
| A.11.1 - Hardware Information.....                                | 312 |
| A.11.2 - Firmware Information .....                               | 313 |



# INTRODUCTION

This manual provides details on terminal operation, maintenance and set-up.

The manual is organized into the following chapters and appendices:

**Chapter 1: Introduction to the AX3000**

Introduction to the AX3000's main features.

**Chapter 2: First Boot Time**

When the terminal is powered-up for the first time, the Quick Set-Up provides a fast and easy method to configure the AX3000. In addition the Auto-Configuration service is started.

**Chapter 3: Interactive set-up**

This is used to set up the terminal's more advanced features. (Multiple sessions, printers, etc)

**Chapter 4: Using the AX3000**

How to use the multi-session feature and shutdown the AX3000.

**Chapter 5: Installing under Windows**

Description of Windows specific features.

**Chapter 6: Installing under OS/400**

Description of 5250 specific features.

**Chapter 7: Installing under OS/390**

Description of 3270 specific features.

**Chapter 8: Installing under Unix/Linux**

Description of Unix/Linux specific features (tty server, multi-shell, VNC server...).

**Chapter 9: Tools and Statistics**

Description of the embedded AX3000 tools (ping, statistics, etc).

**Chapter 10: Remote Administration**

Introduction of AxRM (Axel Remote Management software on Windows)

Description of configuring terminals remotely via 'telnet'

Description of remotely sending a configuration text file to one or multiple terminals.

**Appendices:**

The following appendices give more detailed information:

- A.1 - Using the AX3000 interactive set-up
- A.2 - Network overview (Ethernet address, IP address and routers)
- A.3 - DHCP protocol
- A.4 - DNS protocol
- A.5 - Remote set-up configuration file format
- A.6 - Axel DHCP Option
- A.7 - Setting the IP address by a ping command
- A.8 - Administration command list
- A.9 - Firmware downloading
- A.10 - Going further...
- A.11 - Hardware and firmware information



**- 1 -**

**INTRODUCTION TO THE AX3000**

This chapter introduces the main features of the AXEL TCP/IP terminal.

## 1.1 - TERMINAL MODELS

The manual describes the configuration and the use of all the Axel terminal models. The following table lists the main differences between models:

|                   | M85             | M80F            | M75D                | M75C            | M70F            | M70W            | M75,<br>M75E,<br>M75B | M65C            |
|-------------------|-----------------|-----------------|---------------------|-----------------|-----------------|-----------------|-----------------------|-----------------|
| <b>Connection</b> |                 |                 |                     |                 |                 |                 |                       |                 |
| Ethernet (TCP/IP) | 10/100<br>BaseT | 10/100<br>BaseT | 10/100<br>BaseT     | 10/100<br>BaseT | 10/100<br>BaseT | 10/100<br>BaseT | 10/100<br>BaseT       | 10/100<br>BaseT |
| Wireless (802.11) | option          | ---             | option              | ---             | ---             | ---             | ---                   | ---             |
| Serial (RS232)    | yes             | USB             | yes                 | yes             | ---             | ---             | yes                   | yes             |
| <b>Sessions</b>   |                 |                 |                     |                 |                 |                 |                       |                 |
| Text Emulations   | yes             | yes             | yes                 | yes             | yes             | ---             | yes                   | yes             |
| RDP / ICA         | yes             | yes             | yes                 | yes             | yes             | yes             | yes                   | ---             |
| Virtual Desktop   | yes             | yes             | ---                 | ---             | ---             | ---             | ---                   | ---             |
| VNC Client        | yes             | yes             | yes                 | yes             | yes             | ---             | yes                   | ---             |
| Nbr de colors     | 32bpp           | 32bpp           | 16bpp               | 16bpp           | 16bpp           | 16bpp           | 16bpp                 | ---             |
| <b>Connectors</b> |                 |                 |                     |                 |                 |                 |                       |                 |
| Parallel Port     | 1               | USB             | 1                   | 1               | ---             | ---             | 1                     | 1               |
| Serial port       | 2               | USB             | 2                   | 2               | USB             | USB             | 2                     | 2               |
| USB Port          | 2               | 4               | 2                   | 2               | 2               | 2               | ---                   | ---             |
| USB 2             | yes             | yes             | ---                 | ---             | ---             | ---             | ---                   | ---             |
| <b>Other</b>      |                 |                 |                     |                 |                 |                 |                       |                 |
| USB Driver        | yes             | yes             | Firmware Option MSC |                 |                 |                 | ---                   | ---             |
| Smartcard         | yes             | yes             | Firmware Option SCA |                 |                 |                 | ---                   | ---             |
| Audio             | USB             | USB             | ---                 | ---             | ---             | ---             | ---                   | ---             |
| VNC Server        | yes             | yes             | ---                 | ---             | ---             | ---             | ---                   | ---             |



## 1.2 - MAIN FUNCTIONS

### 1.2.1 - Network Functions

The Axel terminal supports the following network functions:

- DHCP: obtaining an IP address and other parameters
- DNS: publishing the terminal name and resolving server names
- Routing: WAN connection

In addition for the AX3000 M75D and M85 there is a choice of the active interfaces, either Ethernet or Wireless. Only one interface can be active but each provides its own IP settings (DHCP, DNS, routers).

**IMPORTANT:** the wireless interface can't be handled by the 0826 firmware. The terminal must be upgraded with the 0922 firmware.

### 1.2.2 - Terminal Function

Each TCP/IP AXEL terminal can support up to **six concurrent and independent sessions.**

This multi-session capability provides multiple connections across a network. Each session can:

- Connect to any TCP/IP networked server,
- Use different protocols (ica, vnc, rdp, telnet, ssh and tty),
- Have independent parameters (resolution, emulation, etc.)

Programmable keystrokes are used to open or hotkey between sessions.

The maximum number of sessions is 6 but this can be limited to fewer sessions. (Minimum 1)

**Note:** the AX3000 can also act as a RS232 serial terminal.

### 1.2.3 - Print and Terminal Server

The AX3000 auxiliary ports can be managed either:

- By a network service: LPD or PRT5250 for printers, TELNET CLIENT for serial terminals or TTY for other peripherals.

- By escape sequences: compatible with serial terminals. (slave mode)

#### **1.2.4 - Tools and Statistics**

Embedded AX3000 tools provide the following features:

- Ping,
- Remote set-up,
- Statistical environment,
- Firmware downloading.

**- 2 -**  
**INITIAL POWER-ON**

*This chapter describes the 'Quick Set-Up' feature and the 'Auto-Configuration' service.*

When the terminal is switched on up for the very first time two configuration methods are available:

- **Quick Set-Up**: a wizard allows the terminal to be set-up in few seconds for typical use.
- **Auto-Configuration**: used in conjunction with AxRM, this function allows the terminal to automatically receive new firmware and/or a configuration.

## 2.1 - QUICK SET-UP

This feature is automatically run when the AX3000 is powered up for the first time or can be accessed at any time from the interactive set-up, by pressing Ctrl-Alt-Esc (**[Configuration]-[Quick set-up]**).

The quick set-up is designed for a typical simple environment of:

- One server
- An optional router
- All sessions set identically
- An optional printer.

**Note:** After the 'Quick set-up' is run all other parameters within the terminal are reset to their factory default values.

The 'quick set-up' guides the user through a setup menu in an intuitive manner.

The dialog box structure (referred to as a Wizard) is shown below:

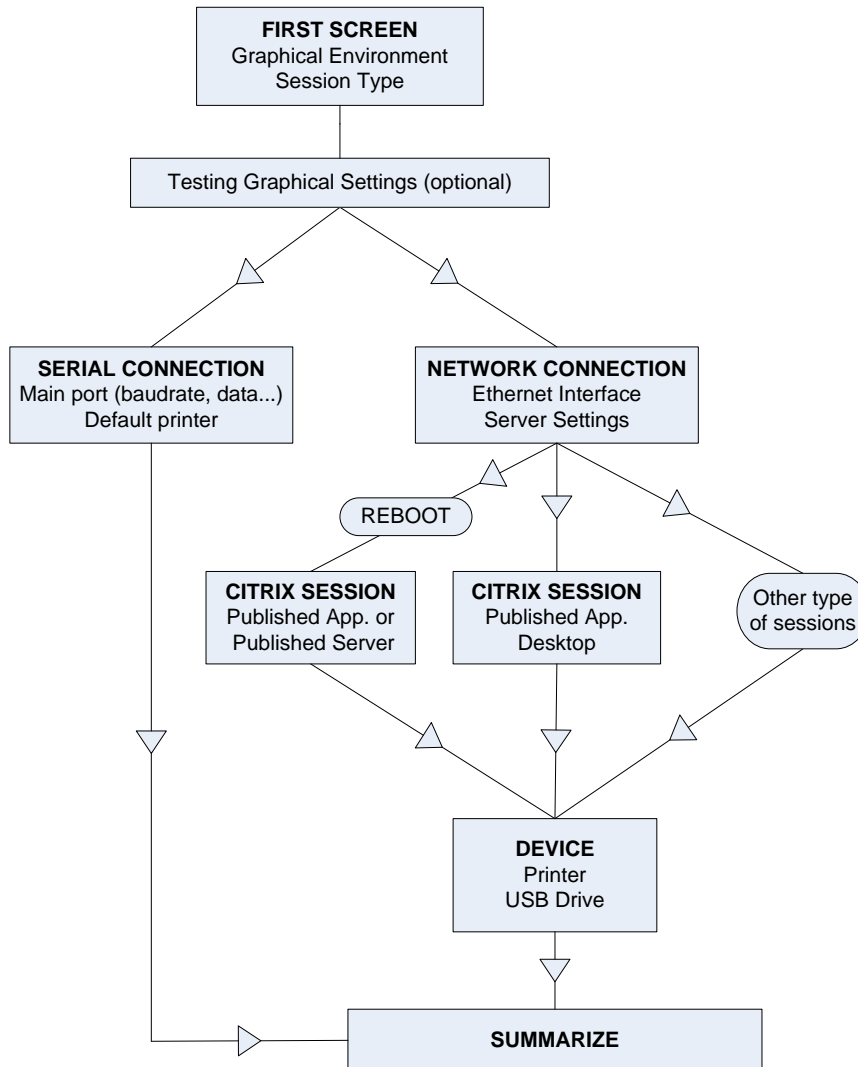

**Note:** the following keystrokes are available in the set-up (for more information see Appendix A.1):

- <Arrows>: moving selection within menus or dialog boxes
- <Enter>: validating a value or a button
- <Esc>: cancels current field (same as using 'cancel' button)
- <Space>: lists of options
- <Tab>: shortcut to buttons on the bottom of the dialog box

### 2.1.1 - First Screen

This first screen allows the session type to be selected:

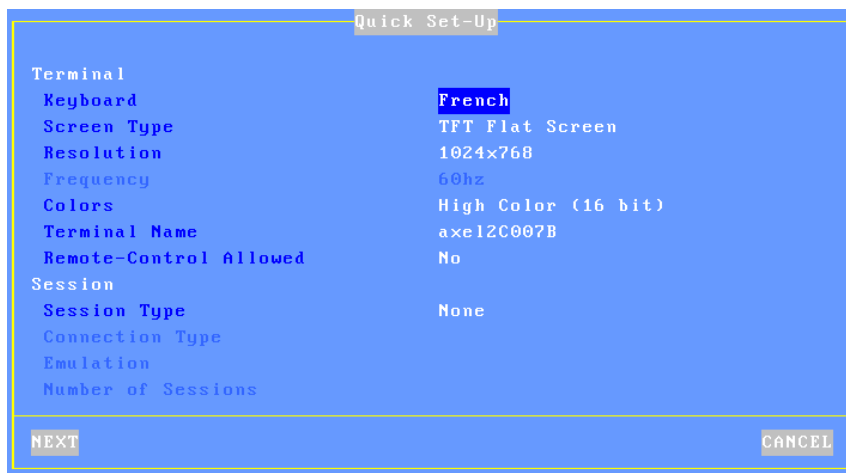

These parameters are:

- **Keyboard:** keyboard nationality. The value selected is used from there on.
- **Screen Type:** options are CRT Monitor or TFT Flat Screen.
- **Resolution:** the default value is monitor-dependent (auto-detection of the recommended value). The available resolutions can vary according to the terminal model. See Chapter 3.2.2.
- **Frequency** (only for CRT monitors): 60Hz or 75Hz.
- **Colors:** according to the terminal model. See Chapter 3.2.2.
- **Terminal Name:** allows the terminal to be identified by its name. (See appendix A.4.3)



The parameters are:

- **Enable DHCP:** two options:
  - **Yes:** the DHCP protocol is run when the set-up is exited and the terminal automatically obtains an IP address and various other DHCP options (netmask, default router, etc).
  - **No:** a Static IP address is required
- **IP address:** mandatory if DHCP is disabled.
- **Default router:** optional router IP address.
- **1st DNS Server IP Address:** optional DNS server IP address
- **Server Name** (not available for Citrix): DNS name (if the DNS server is known) or a simple mnemonic name. (a name must be entered)
- **Server IP address** (not available for Citrix): if this field is left blank, DNS will be used to resolve the hostname.
- **TCP Port** (only for VNC): VNC session number

**Note:** for a "Virtual Desktop" session, the server is the "Connection Broker"

For more information about DHCP and DNS, please refer to appendices A.3 and A.4.

### **2.1.3 - Devices**

This box is displayed for the all networked session types:

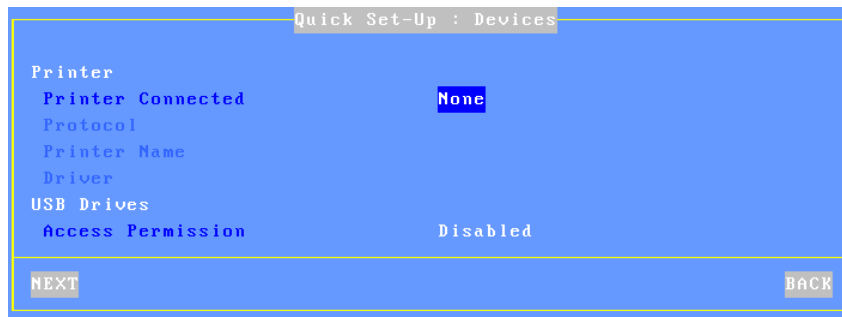



These parameters are:

- **Printer Connected:** auxiliary port where printer is attached (none, aux1, aux2, parallel, USB1).
- **Protocol:** LPD, TSE, Prt5250 or Prt3270. The next parameters are protocol-dependent:
  - LPD: **Queue Name** (name given to the auxiliary port)
  - TSE: **Printer Name** and **Windows TSE Driver**
  - Prt5250: **Printer Name** and **Driver** (printer type and model)
  - Prt3270: **Printer Name**
- **Access Permission:** only for TSE and Citrix sessions where USB Mass Storage is supported.

**2.1.4 - Citrix Published Application Desktop**

For session type 'Citrix (ica)' and connection type 'Published App. Desktop', the following box is displayed:

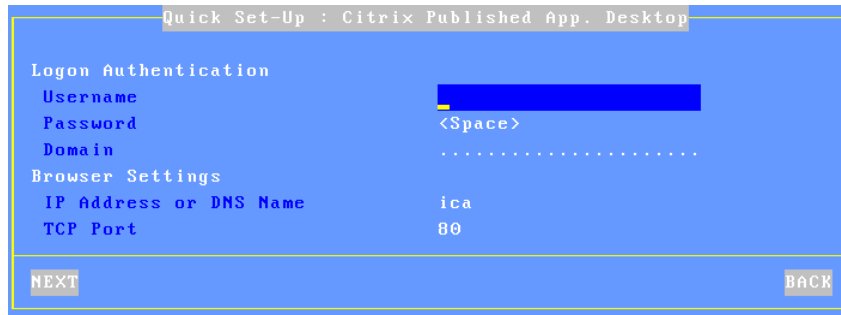

These parameters are:

- **Username:** default value for logon authentication (optional).
- **Password:** press <Space> to enter the logon password.
- **Domain:** default value for logon authentication.
- **IP Address or DNS Name:** location of a farm's server
- **Port TCP:** used by the exploration (browser) protocol

### **2.1.5 - Citrix (Published Application or Published Server)**

For the session type 'Citrix (ica)' with the connection type 'Published Application' or 'Published Server', the following box is displayed (after the terminal reboots):

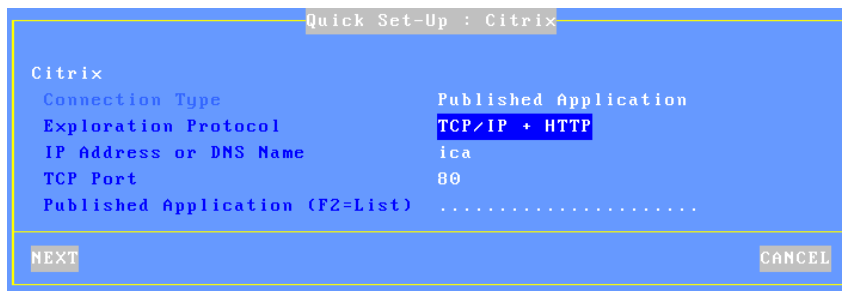

These parameters are:

- **Connection Type:** Selected in previous dialog box.
- **Exploration Protocol:** possible values are:
  - TCP/IP + HTTP: XML-based exploration
  - TCP/IP: UDP-based exploration
- **TCP Port:** used by the exploration protocol
- **IP Address or DNS Name:** location of a server farm, overwrite default of 'ica' if necessary
- **Published Application or Published Server:** press <F2> to show the list from the Citrix farm.

### **2.1.6 - Serial Connection**

**Note:** Depending on model, if an AUX1 port is available on the terminal rear panel this is the main port, if not a third party USB-COM adaptor is requested. (Note, this component is not supplied by Axel)

Where the session type is 'Text Emulation' and connection type is 'aux1' the following box is displayed:

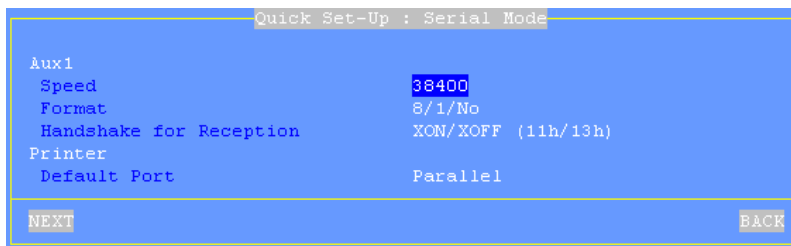

```
Quick Set-Up : Serial Mode
Aux1
Speed          38400
Format         8/1/No
Handshake for Reception XON/XOFF (11h/13h)
Printer
Default Port   Parallel
NEXT          BACK
```

These parameters are:

- **Speed:** press <Space> to select the baud rate
- **Format:** press <Space> to select the data format
- **Handshake for reception:** press <Space> to select the handshake
- **Default Port:** auxiliary port used for local printings.

### 2.1.7 - Set-Up Summary

At the end of the wizard process, a summary of the selected settings is displayed. For example:



Press the [ACCEPT] button to use these settings. After an automatic reboot the terminal is ready to be used.

The [Advanced] button enters the interactive setup where further configuring is possible. For example adding different session types.

The [BACK] button allows these settings to be changed.

## 2.2 - AUTO-CONFIGURATION

The Auto-Configuration feature allows a brand new 'out of the box' terminal to be sent a specific firmware and/or configuration file without any human

intervention. There are also options to specify various terminal specific parameters, for example an IP address and terminal name etc.

**Note:** the auto-configuration mechanism requires minimum version 2.0.2 of AxRM (available free from [www.axel.com](http://www.axel.com)).

For more information on AxRM's activity in the auto-configuration process, see the manual "Axel Remote Management - Version 2", available from [www.axel.com](http://www.axel.com).

The auto-configuration process:

- Is automatically initiated when power is applied to a brand new terminal or if the terminal is reset to factory defaults - see A.10.1 appendix.
- may be started at each boot time. For more information see Chapter 3.7.2.

The stages are:

- Checking the network (link),
  - DHCP request sent to obtain an IP address and other parameters (optional),
  - Terminal contacts the AxRM server,
  - Firmware file sent (if required), followed by a reboot,
  - Configuration file sent, followed by a reboot.
- Total process takes less than two minutes

### **2.2.1 - Stage 1: Checking the Network**

When the terminal is powered up the network connection is tested. The terminal displays 'Checking Network Link'. If a network connection is detected, a message 'Auto-Conf' is shown. The terminal passes to stage 2.

```
Auto-conf.
```

### **2.2.2 - Stage 2: Sending DHCP requests**

To obtain an IP address (and possibly of other parameters) a DHCP request is sent. If a DHCP server is available its IP address is shown in the status line:

```
Auto-conf. / DHCP: aaa.bbb.ccc.ddd /
```

The terminal passes to stage 3

### **2.2.3 - Stage 3: Sending requests to AxRM**

After obtaining an IP address via DHCP negotiation the terminal must start communicating with the AxRM server.

This presents a challenge because the terminal must determine both the IP address and the TCP port of the AxRM server.

The recommended way is to configure the DHCP server to send this information in addition to the AX3000 IP address. This information (IP address and port) can easily be entered into the DHCP server by using the vendor ID fields. "Axel DHCP option".

For more information about "Axel DHCP option" please consult the Appendix A.6.

#### ***a) Determining the TCP port***

If DHCP sends a port number this is used.

If no value is received a default value of port 80 is used.

#### ***b) Determining IP address***

Method 1:

If the IP address or DNS name is given by the DHCP server (through Axel DHCP option) then this is the information the terminal uses to locate the AxRM server.

Method 2:

If DHCP does not supply these values the terminal will try to resolve a 'hardwired' DNS name "axrmserv".

If the name is resolved the terminal can find the AxRM server. The name axrmserv must be configured within DNS to resolve to the IP address of the AxRM PC. A DNS alias can be used to allow the AxRM PC to have two names, i.e. its original name AND axrmserv.

**Method 3:**

If "axrmserv" cannot be resolved, as a final attempt the terminal assumes AxRM resides on the same PC as the DHCP server.

**Method 4:**

Only used when the location (IP address or name) and the TCP port of the AxRM machine are specified within the AX3000 Set-Up. See Chapter 3.7.2. (This is not viable for setting up brand new terminals, as required AxRM PC data to be already entered in the terminal setup)

The IP address of the AxRM server and the location method used is shown on the status line:

```
Auto-Conf. / DHCP: aaa.bbb.ccc.ddd / AxRM (1): www.xxx.yyy.zzz:nnnn.....
```

The terminal sends an 'auto-configuration' request to AxRM every 5 seconds. If no response is received after 10 attempts the terminal starts the mechanism again, i.e. from stage 1.

This loop stops when either AxRM responds or if a user presses any key on the keyboard, causing the normal interactive quick setup to run.

**2.2.4 - Stage 4: Receiving the firmware download**

A dialog box on the terminal screen provides the status. From this stage the mechanism cannot be aborted.

Note that firmware downloading may not have been specified by AxRM, in which case the procedure passes directly to stage 5.

The dialog box is as shown:

```
AUTO-CONFIGURATION

Network detection.....100BT-FD
IP Address.....a.b.c.d
DHCP Server.....e.f.g.h
AxRM Server.....i.j.k.l:n
Firmware update.....in progress
Config update.....
Reboot.....
```

After having received the firmware the terminal reboots automatically and re-runs stages 1, 2 and 3 before passing on to stage 5.

### **2.2.5 - Stage 5: Receiving the configuration file**

This is the dialog box shown when receiving the configuration file:

```
AUTO-CONFIGURATION

Network detection.....100BT-FD
IP Address.....a.b.c.d
DHCP Server.....e.f.g.h
AxRM Server.....i.j.k.l:n
Firmware update.....TCP.XX.0826a.STD
Config update.....in progress
Reboot.....
```



**Note:** if the firmware is updated the new version is displayed. After the configuration file is received the terminal reboots:

```
AUTO-CONFIGURATION

Network detection.....100BT-FD
IP Address.....a.b.c.d
DHCP Server.....e.f.g.h
AxRM Server.....i.j.k.l:n
Firmware update.....TCP.XX.0826a.STD
Config update.....OK
Reboot.....in progress
```

The terminal is now ready for use.



**- 3 -**  
**INTERACTIVE SET-UP**

*This chapter describes AX3000 installation using the interactive set-up procedure.*

The following can be used to enter the AX3000 interactive set-up:

- Using <Ctrl><Alt><Esc> from the terminal
- Using Remote Control from AxRM. (See Chapters 10.1 and 10.2)
- Using Telnet from another terminal/PC. (See Chapter 10.3)

**Note:** the set-up can be password-protected, in which case the password must be entered to access the quick set-up dialog box. For more information, see Chapter 3.2.7.

**Note:** the following keystrokes are available in the set-up (for more information see Appendix A.1):

- <Arrows>: moving selection within menus or dialog boxes
- <Enter>: validating a value or a button
- <Esc>: cancels current field same as selecting 'cancel' button
- <Space>: open a list of options
- <Tab>: short cut to buttons at the bottom of the dialog box
- <Ctrl><C>: copy a character string or session settings
- <Ctrl><V>: paste information

### 3.1 - SETTING NETWORK ENVIRONMENT

The network settings are available through the **[Configuration]-[Network]** menu:

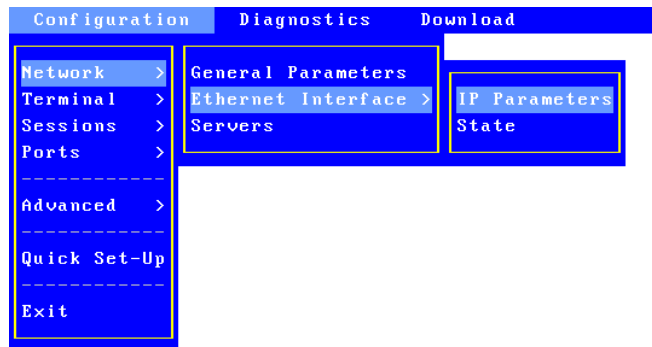

This chapter covers the AX3000 network configuration:

- **General Parameters:** the terminal identification and the interface activation
- **Ethernet Interface:** static or dynamic IP address, DNS protocol and router management
- **Servers:** manages the server list.

**Note:** more information is given in the following appendices:

- Appendix A.2: Ethernet addresses, IP addresses, net masks and routers,
- Appendix A.3: DHCP protocol,
- Appendix A.4: DNS protocol.

### 3.1.1 - General Parameters

To set the AX3000 interface and the terminal identification select the **[Configuration]-[Network]-[General Parameters]** menu. The dialog box below is displayed:

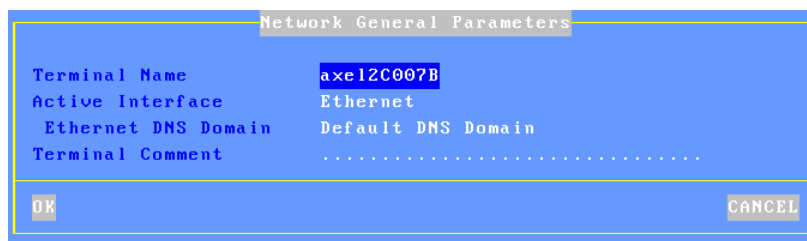

| Network General Parameters |                    |
|----------------------------|--------------------|
| Terminal Name              | axel12C007B        |
| Active Interface           | Ethernet           |
| Ethernet DNS Domain        | Default DNS Domain |
| Terminal Comment           | .....              |

OK CANCEL

#### a) The Terminal Name

A terminal name is mandatory – though need not be used. By default the terminal name is set to 'axel' suffixed by the last part of the MAC Ethernet address. For example 'axel200002'. This ensures all terminals have a unique default name.

The same name is given to the default connection name for RDP or ICA connections, though this can be changed.

If the terminal name is to be used as a DNS name (i.e. registered to a DNS server) an extension is required. This extension is called "DNS domain". For example 'paris.axel.fr'.

Registering an entry with the DNS server requires an FQDN. (Fully Qualified Domain Name) If the "DNS Domain" parameter is empty, the "Default DNS Domain" (supplied by the DHCP server) will be used. If "Default DNS Domain" is empty, the name won't be registered.

The name registration can be performed by the DHCP server or by the terminal itself. For more information see the next chapter and the appendix A.4.3.

**b) Active Interface**

This parameter selects which interface to be used. Possible values are:

- **Ethernet:** a DNS domain name can be specified,
- **None (serial mode)**

**c) The Terminal Comment**

This character string allows a terminal description to be entered. This description will be obtained by the Axel Remote Management software (AxRM) during the 'discover' operation. This comment will allow the terminal to be easily located within the database.

**3.1.2 - Ethernet Interface**

To set the Ethernet interface properties select the **[Configuration]-[Network]-[Ethernet Interface]-[IP Parameters]** menu. The dialog box below is displayed:

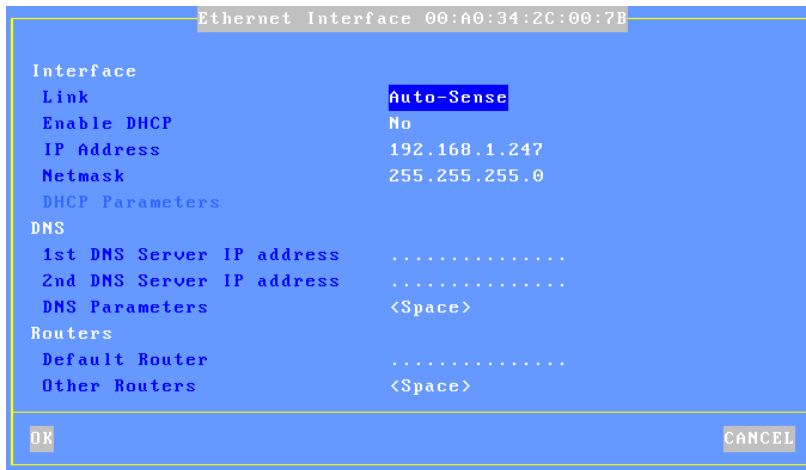

**Note:** the Ethernet address is displayed as the title box

The "**Link**" parameter is set by default as auto-sense. Available modes are:

- Auto-sense,
- 10BT HalfDuplex,
- 10BT FullDuplex,
- 100BT HalfDuplex,
- 100BT FullDuplex.

The next sub-chapters deal with:

- The interface setting (static or dynamic IP address)
- The DNS protocol.
- The router management,

#### **a) Static or Dynamic IP Address**

The DHCP protocol allows the terminal's IP address (and other parameters) to be obtained at the boot time.

When "**Enable DHCP**" is set to "**Yes**", the **IP Address'** field is not available and the DHCP settings are set through the "**DHCP Parameters**" option. Press <Space> to display the dialog box:



The DHCP Option List allows certain parameters to be automatically assigned by DHCP.



Other parameters are:

- **Lease Time (minutes):** lease time value requested by the AX3000 from the DHCP server. Depending on the DHCP server settings this parameter may be ignored. The AX3000 automatically renews the lease when it expires.
- **Free IP address when shutdown:** by default when the terminal is shutdown a command to release the IP address is sent to the DHCP server. Set this option to 'no' to change that.
- **Client Identifier:** allows the terminal to be identified not only by the Ethernet address (useful to control IP address assignment).
- **User Class Identifier:** allows the DHCP server to assign settings in regards of a class of device.
- **Trace Mode:** in the event of problems this mode allows the data exchanged between the AX3000 and the DHCP server to be displayed on the screen. The trace data is displayed directly on the AX3000 screen (i.e. messages may 'pollute' the AX3000 display at any time).
- **Check IP Address:** the AX3000 checks its allocated IP address is not already in use.

#### ***b) DNS Protocol***

To resolve a name, the AX3000 sends DNS requests to a DNS server. The IP address of this DNS server must be known. The AX3000 set-up procedure allows two DNS servers to be entered.

**Note:** if 'DNS Servers' is selected the "DHCP Option List" these two parameters are supplied by DHCP and cannot be accessed here.

Other DNS settings are available through the "DNS Parameters" option. Press <Space> and the dialog box below is displayed:

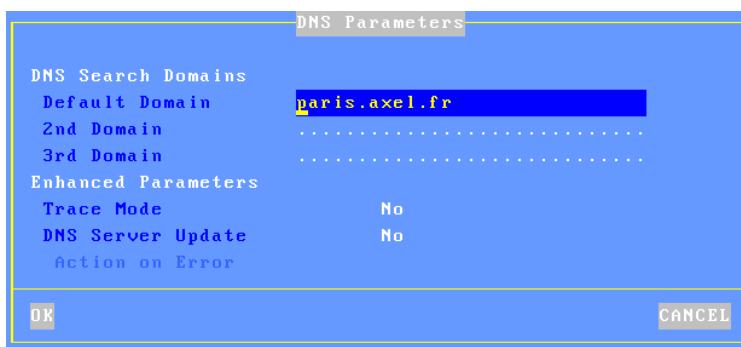

Parameters are:

- **DNS Search Domains:** a DNS domain is used to resolve a server name or to register the terminal name (see Appendix A.4).  
**Note:** if the 'Default DNS Domain' is selected in the "DHCP Option List", the 'Default Domain' parameter cannot be accessed.
- **Trace Mode:** in the event of problems this mode allows the data exchanged between the AX3000 and the DNS server to be displayed.
- **DNS Server Update:** sets the method used for publishing the terminal name:
  - **No:** the terminal name is not published.
  - **By the DHCP server** (available only if the DHCP protocol is enabled): the terminal name is registered by the DHCP server. Requirement: the DDNS function (Dynamic DNS) must be supported by the DHCP server. See Appendix A.4.3.
  - **By the terminal:** the terminal updates the DNS server. In this case the parameter "Action on Error" controls the terminal's behavior in the event of an error during the DNS server update (see Appendix A.4.3).

### ***c) Router Management***

A router is either a special electronic device, or a suitably configured computer, which enables data to be sent across two or more distinct physical networks.



To configure the server table, select the **[Configuration]-[Network]-[Servers]** menu. A dialog box as shown below is displayed:

| Server Name             | IP Address           |
|-------------------------|----------------------|
| as400                   | (DNS)                |
| linux                   | 192.168.1.190        |
| windows.server.axel.com | (DNS)                |
| .....                   | .....                |
| .....                   | .....                |
| .....                   | .....                |
| .....                   | .....                |
| .....                   | .....                |
| .....                   | .....                |
| DNS Search Domains      |                      |
| Default Domain          | paris.axel.fr (DHCP) |
| 2nd Domain              | .....                |
| 3rd Domain              | .....                |

VALID      DELETE      CANCEL

The server definition depends on whether DNS is enabled:

- **No DNS:** a server is identified by both an alphanumeric character string beginning with a letter AND an IP address.
- **With DNS:** a server is defined only by its name. This name can be either a full name (www.axel.com) or an incomplete name (as400). Its IP address is resolved later. (See Appendix A.4)

**Add a Server:** move the highlight cursor to a vacant line and enter the name and either its IP address or DNS name.

**Delete a Server:** select the server and press [DELETE].

**Change a Server:** move the highlight cursor over the name or IP address of the server and enter the new value.

**Note:** the default DNS domains, previously defined through the DNS box are displayed for information (they can not be modified).

### 3.2 - GENERAL SETTINGS

The terminal general settings are available through the **[Configuration]-[Terminal]** menu:

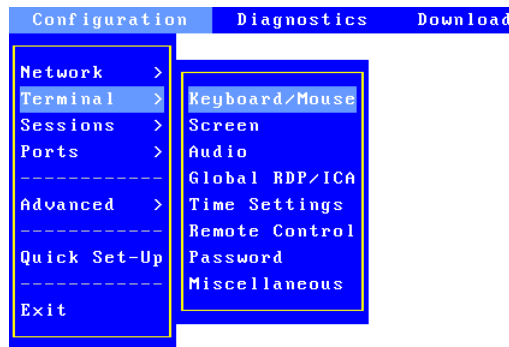

#### 3.2.1 - The Keyboard and the Mouse

Select the **[Configuration]-[Terminal]-[Keyboard/Mouse]** menu to access the following dialog box:



Keyboard parameters (PS/2 or USB):

- **Nationality**: select the nationality from a list
- **'NUM' Led Initialization**: this led lights when the AX3000 is switched on
- **'CAPS' Led Initialization**: this led lights when the AX3000 is switched on

- **Repeat Key Delay**: sets the duration of a key being held down before it starts to auto-repeat (values: no, low, medium or high).
- **Repeat Key Speed** (enabled only if the automatic repeat is set): select the automatic repeat speed when a key is held down (values: low, medium or high).

Mouse parameters (PS/2 or USB):

- **Switch Left/Right Click**: mouse button reversal
- **Mouse Accelerator**: can be helpful with wide screens.

### **3.2.2 - The Screen**

Select the **[Configuration]-[Terminal]-[Screen]** menu to access the following dialog box:



#### ***a) Graphical Environment***

Parameters are:

- **Screen Type**: the available values are:
  - CRT Standard Monitor: color VGA/SVGA monitor,
  - TFT Flat Screen.
- **Resolution**: available values depend on the terminal model. (See the following table).

- **Frequency** (only for CRT monitors): 60Hz or 75Hz.
- **Colors**: available values depend on the terminal model. (See the following table).

The following table shows the number of colors and resolution per model:

|                           | M85, M80F | M75x, M70x | M65C |
|---------------------------|-----------|------------|------|
| <b>Number of Colors</b>   |           |            |      |
| 24 and 32 bpp             | yes       | ---        | ---  |
| 16 bpp                    | yes       | yes        | ---  |
| 8 bpp                     | yes       | yes        | ---  |
| <b>Aspect Ratio 4:3</b>   |           |            |      |
| 640x480                   | ---       | yes        | ---  |
| 800x600                   | yes       | yes        | ---  |
| 1024x768                  | yes       | yes        | ---  |
| 1280x960                  | yes       | ---        | ---  |
| 1280x1024                 | yes       | yes        | ---  |
| 1600x1200                 | yes       | ---        | ---  |
| <b>Aspect Ratio 16:9</b>  |           |            |      |
| 1280x720                  | ---       | yes        | ---  |
| 1360x768                  | yes       | 1344x768   | ---  |
| 1600x900                  | yes       | yes        | ---  |
| 1920x1080                 | yes       | ---        | ---  |
| <b>Aspect Ratio 16:10</b> |           |            |      |
| 1440x900                  | yes       | yes        | ---  |
| 1680x1050                 | oui       | ---        | ---  |
| 1920x1200                 | oui       | ---        | ---  |

**Note:** when exiting the dialog box the graphical settings may be tested.

**b) Screen Saver**

Parameters are:

- **Screen Saver**: this function automatically either blacks out the monitor display (after a certain time of inactivity) or allows the screen to be locked during the AX3000 use:
  - No: function disabled.
  - Yes: function enabled. The display is restored when either the keyboard is used or data is received from the server.

- Yes keyboard only: The display is only restored when the keyboard is used.
- **Energy Star Power Saver** (available only if the screen saver feature is enabled): this saves monitor power consumption.
- **Password** (available only if the screen saver feature is set): the lock screen feature is only available if a password is entered. Press <Space> to enter the password. For more information about the lock screen feature, see Chapter 4.3.
- **Delay (minutes)** (available only if the screen saver feature is set): delay before the monitor is turned off or locked.

### c) Touch Screen

"Touch screen events" are automatically remapped into "mouse events". No additional drivers or settings are required on the server (Windows, Unix/Linux, AS/400...).

Touch screen parameters:

- **Port:** serial touch screen port (Aux1, Aux2...)  
For a USB touch screen this parameter is disabled
- **Settings:** press <Space>. The displayed box depends on the touch screen type (serial or USB):



**Type** (serial touch screens only): select the touch screen manufacturer: ELOTouch, MicroTouch or Liyitec.

**Automatic Detection** (serial touch screens only): press <Space> to automatically obtain the set-up parameters from the touch-screen. To detect these settings the Axel terminal scans a range of baud rates and data formats. When these match the touch screen settings the serial line parameters are



updated.

**Calibration:** press <Space> to display a dialog box for calibration. (Follow the instructions and touch the screen where '\*'s are displayed).

**Events sent** (USB touch screens only): two modes are available:

- **Click Only:** a 'mouse click' event is sent when the screen is touched
- **All:** in addition of the click event, 'mouse motion' events are sent until the screen is untouched.

**Transpose X/Y Axis** (USB touch screens only): select 'yes' or 'no'.

**Double Touch Accuracy Range (pixels):** this parameter defines a zone size which allows double-click to be emulated. A double-click event will be sent when the screen is touched twice (in a period less than 0.5 seconds) and when the two impacts are located in the same zone (less than X pixels).

**Note:** the touch screen functions properly only after the calibration has been performed.

After calibration touch screen events are automatically remapped to the following mouse events:

- 5250 emulations: left double-click
- Other emulations or protocols: left click

### 3.2.3 - Audio

Select the **[Configuration]-[Terminal]-[Audio]** menu to access the following dialog box:

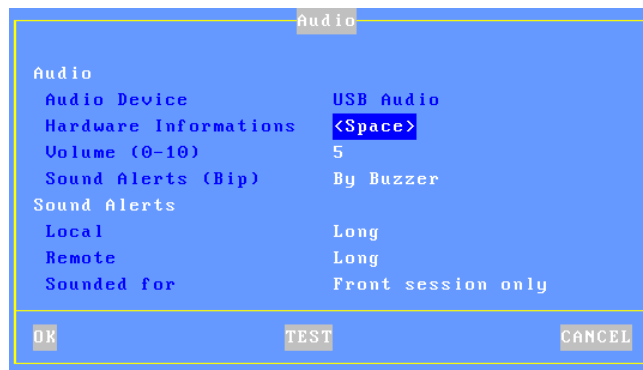

#### a) Audio Device

When an audio device is detected its type is displayed (USB Audio). In this case the following options are available:

- **Hardware Information:** miscellaneous information.
- **Volume:** setting-up the volume (0=mute).
- **Sound Alerts:** selecting the output device: buzzer or audio device.

#### b) Sound Alerts

A sound alert is a bell sound. Two types of sound alerts are available. For each one, the beep can be disabled or the duration can be set. (Values: no, short, long or very long.):

- **Local:** following an unexpected operation the terminal sounds a beep.
- **Remote:** the beep is requested by the server (escape sequence).
- **Sounded for:** set if the remote alert is played for "**Front session only**" or for "**Any session**".

### 3.2.4 - Global RDP/ICA

Select the **[Configuration]-[Terminal]-[Global RDP/ICA]** menu to access settings specific to RDP/ICA environment. The following dialog box is displayed:

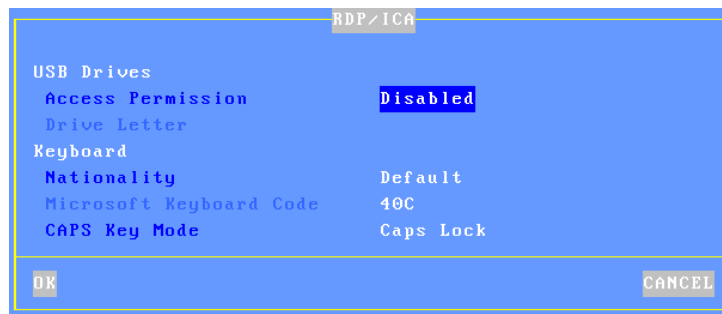

#### a) USB Drives

External USB mass storage devices (memory sticks, hard drives, CD/DVD readers...) are redirected to the Windows/Citrix server and are seen as local drives

The USB drive parameters are:

- **Access Permission:** two modes are available:
  - **Read Only:** writing is not allowed but multiple RDP/ICA sessions can read the USB drive
  - **Read/Write:** read and write access permitted by only for a single session
- **Driver Letter:** mnemonic given to the Windows server.

**Important:** this box allows “global” parameters to be set-up. It is necessary to also enabled/disable USB drive redirection per session (see Chapters 5.1.5 and 5.2.6).

#### b) Keyboard Nationality

When the nationality of the keyboard is not listed by the terminal setup, a country specific Microsoft keyboard code can be specified. This code is used when an RDP/ICA session is established and allows any keyboard nationality to

be negotiated and supported by the terminal.

**Note:** The country code is only applied after a Windows connection is established – so is not available at the terminal setup level.

The RDP/ICA Keyboard parameters are:

- **Nationality:** two possible values:
  - **Default:** the keyboard nationality is given by the [Configuration]-[General]-[Keyboard] menu. This setting is used by default for Windows sessions, and if listed and selected no further action is required. (This same nationality is used for character based sessions and terminal setup menus)
  - **Custom:** for nationalities not listed a custom keyboard nationality can be entered. (Microsoft Keyboard Code parameter)
- **Microsoft Keyboard Code:** enter the required keyboard code value. See Appendix A.10.4 for valid values.
- **CAPS Key Mode:** select "Shift Lock" or "Caps Lock".

### **3.2.5 - Time Settings**

The time management is used for:

- Displaying date and time within the local status bar.
- Updating modification/creation file time (memory stick support)
- Automatic terminal reboot

Select the **[Configuration]-[Terminal]-[Time settings]** menu. The following dialog box is displayed:

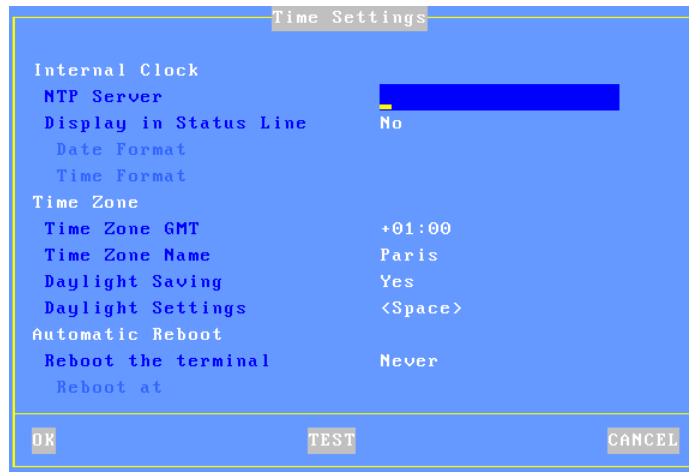

#### **a) Internal Clock**

Unlike a PC, there is no local clock (with battery) in Axel terminals. To provide a local clock we have introduced support for a time client (NTP protocol). This allows the time to be obtained when the terminal is powered on.

Enter the time server IP address (or the DNS name). This information can be automatically obtained via the DHCP protocol. (See Chapter 3.1.2).

The date and time can be displayed within the terminal status bar. The following option allows the display formats to be selected:

- **Date Format:** 'JJ/MM/AA' or 'MM/JJ/AA'
- **Time Format :** 'HH:MM' or 'hh:MM'. (For the second format the time is displayed 'modulo 12' with PM or AM after.)

#### **b) Time Redirection**

The terminal negotiates its own local time zone. This allows different 'local times' to be displayed on terminals in different geographic regions?

**Note:** the time zone redirection function must be enabled on the Windows 2003 server. See Chapter 5.5.6.

The time zone parameters are:

- **Time Zone GMT:** positive or negative offset from GMT.
- **Time Zone Name:** a non-empty character string (Greenwich by default).
- **Daylight Saving:** enabling daylight saving function.
- **Daylight Settings:** press <Space> to customize daylight settings. The following dialog box is displayed:

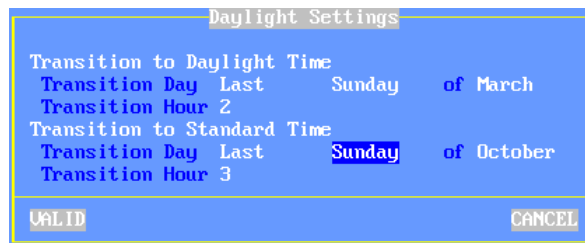

Enter the following parameters for each transition time:

- **Transition Day:** day number, day and month. (For example: Last Sunday of March for daylight time.)
- **Transition Hour:** enter the hour without minute. (For example: 2 is 02:00.)

### c) Automatic Reboot

When a NTP server is set, the terminal can be automatically rebooted (every day or a specific day). This can be used with the auto-configuration feature.

### 3.2.6 - Terminal Remote Control

To set-up the remote control function, select the menu **[Configuration]-[Terminal]-[Remote Control]**. The following dialog box is displayed:

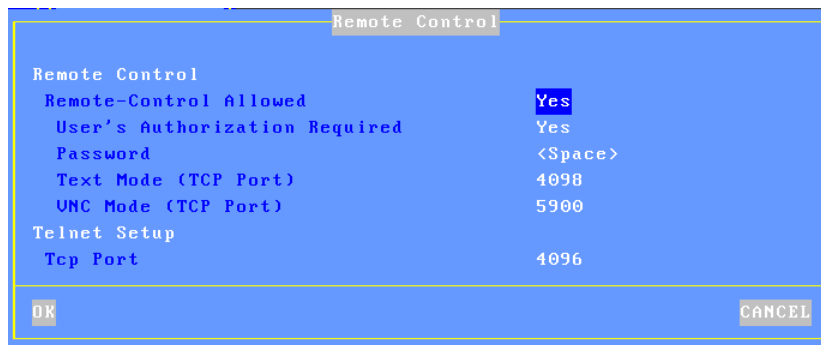

#### a) Remote Control

This functionality allows an administrator to remotely take control of a terminal. The administrator can passively watch the users screen or actively take control with his own keyboard for various support or administration purposes.

The parameters are:

- **Remote-Control Allowed:** yes or no.
- **User's Authorization Required:** when this parameter is set the remote control must be accepted by the current user of the terminal.
- **Text Mode (TCP Port):** remote control only for text-based session (terminal set-up, telnet, 5250 & 3270)
- **VNC Mode (TCP Port):** global remote control
- **Password (optional):** this password will be requested when the connection is established.

For more information, refer to Chapter 10.2.

#### b) Telnet Set-Up

This functionality allows the terminal set-up to be addressed by a telnet client.

The single parameter is the TCP port (4096 by default).

For more information, refer to Chapter 10.3.

(Note Windows telnet client requires specific arguments given in Chapter 10.3)

### **3.2.7 - Password**

Access to the set-up menus can be controlled by a password.

#### ***a) Setting the Password***

Select the **[Configuration]-[Terminal]-[Password]** dialog box to set, change or delete the set-up password:

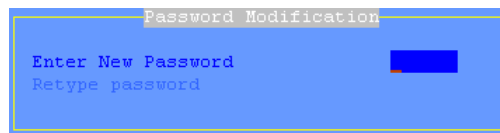

Enter the following parameters:

- **Enter a new password:** enter a new password of maximum five characters, or press <CR> if no password is required or to delete existing password.
- **Retype password:** re-enter the identical password.

#### ***b) Entering Set-Up***

If the set-up is password protected, the following dialog box will be displayed the next time access is attempted:

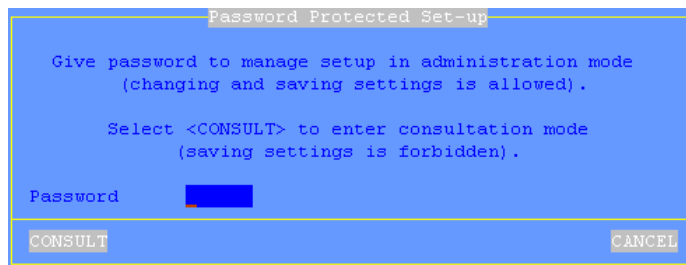



Three operations are permitted:

- enter the password to access the set-up
- press **<Esc>** or select the [CANCEL] button to exit set-up mode
- select the [CONSULTATION] button to access the set-up without using the password. All set-up operations will be permitted but **it will not be possible to save the modifications.**

**IMPORTANT:** if the password is not known, the super password '**yaka**' can be used. (Only from the local interactive set-up and only if "Administrator Hot Key disabled" is set to "No". See Appendix A.10.2.)

### **3.2.8 - Miscellaneous**

Select the [**Configuration**]-[**Terminal**]-[**Miscellaneous**] menu to access the following dialog box:

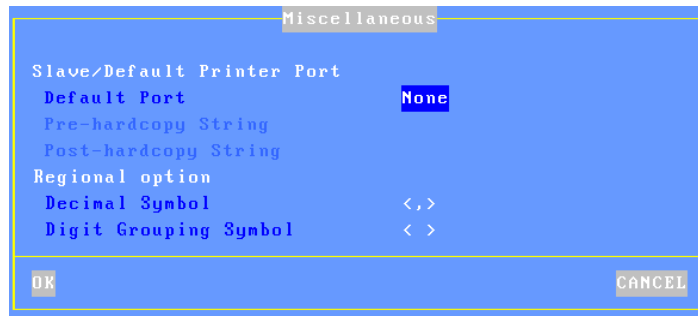

#### ***a) Default Printer Port***

The default port is used for screen dumps or to select the default port for printing via escape sequences (for text-mode emulations).

Printer parameters:

- **Default port:** press **<Space>** to select the port.
- **Pre-hardcopy String** (available if "default port" isn't "none"): character string sent before a hardcopy.
- **Post-hardcopy String** (available if "default port" isn't "none"): character string sent after a hardcopy (for example "\0C" is a form feed)

**Note:** If "Choose Portrait/Landscape" is enabled (see Appendix A.10.2), the parameter "**Pre-hardcopy String**" is replaced by the two parameters "**Portrait Pre-print String**" and "**Landscape Pre-print String**".

#### ***b) Regional Option***

These two options allow numbers to be distinguished when a copy/paste operation is done from a text-based session to an RDP/ICA session. (Useful when the paste operation is done to spreadsheet software).

The decimal symbol can be a comma or a dot.

The digit grouping symbol can be a dot, a comma or a space.

### **3.3 - SETTING EACH SESSION**

The AX3000's built-in multi-connection capability allows simultaneous access to up to 6 different servers on one or more Ethernet networks or by serial connection.

Each independent session has:

- A connection: TCP/IP protocol and associated server
- A virtual terminal: emulation, function key values, number of lines, etc

Select the **[Configuration]-[Sessions]-[Session X]** menu (where **X** is the session number). The "Session Type" list is displayed:

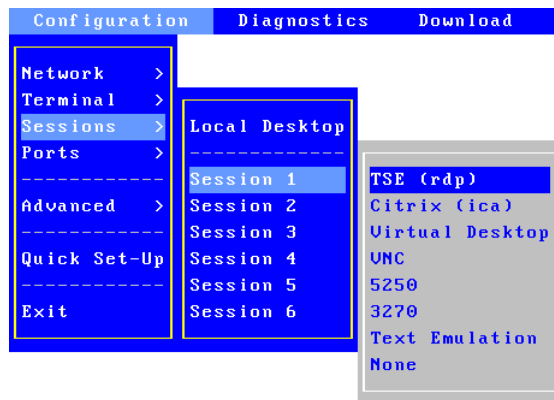

**Note:** if the session was already associated with a "Session Type" the related dialog box is displayed.

### **3.3.1 - "TSE (rdp)" or "Citrix (Ica)", "Virtual Desktop" Session Types**

Graphical mode session for connections to Windows (TSE servers, Citrix servers or virtual machines).

For more information refer to Chapter 5.

### **3.3.2 - "VNC" Session Type**

Graphical mode session for connections to Unix/Linux.

For more information refer to Chapter 8.2.

### **3.3.3 - "5250" Session Type**

Text mode session for connections to AS/400.

For more information refer to Chapter 6.

### **3.3.4 - "3270" Session Type**

Text mode session for connections to OS/390.

For more information refer to Chapter 7.

### **3.3.5 - "Text Emulation" Session Type**

Network (**telnet**, **ssh** and **tty** protocols) or serial (**aux1** and **aux2** ports) text mode sessions are generally used for Unix/Linux connections.

For more information, refer to Chapter 8.1.

### **3.3.6 - "None" Session Type**

The session is no longer available for the user.

### **3.3.7 - Duplicating Session Settings**

The settings of a "source" session may be duplicated to a 'destination' session.

In the **[Configuration]-[Sessions]** menu, select the source session and press <Ctrl><C>. Then select the destination session and press <Ctrl><V>.

After confirmation, the source session settings are applied to the destination session.

## **3.4 - USB MANAGEMENT**

### **3.4.1 - Specifications**

Technical specifications:

- Supported speeds:
  - All models: Low-speed (1,5 Mbits) and Full-speed (12 Mbits)
  - Models 80 & 85: high-speed (480 Mbits)
- Maximal consumption: 500 mA (total current draw for all ports)

**Important Note:** power hungry non-computing USB devices must not be connected to the terminal (fans, lights...) as they have the potential to draw too much current and cause damage to the terminal.

The following USB devices are supported:

- Keyboard,
- Barcode reader,
- Mouse,
- HUB,
- Printer,
- USB-RS232 adaptor,
- Touch screen,
- Mass storage device (memory stick, hard drives, CD/DVD readers...),
- Smartcard reader (or security USB dongle from Aladdin),
- Audio device.

Other USB devices are detected but not supported.

USB devices are hot-pluggable and are dynamically detected by the Axel terminal.

Maximum number of connected USB devices:

- Two keyboards and barcode readers,
- Two mice,
- Two HUBs,
- Four printers or USB-RS232 adaptors,
- One touch screen.
- One mass storage device,
- Two smartcard readers.
- One audio device.

### **3.4.2 - Connecting a USB Keyboard**

The USB keyboard is automatically detected by the Axel terminal.

The USB keyboard settings (nationality, LED initialization...) are displayed and can be changed in the AX3000's General Parameters. For more information see Chapter 3.2.1.

**Note:** multiple keyboards (USB and/or PS2) can be connected. The same settings are used for both and they can be used simultaneously.

#### **3.4.3 - Connecting a USB Barcode Reader**

The USB barcode reader is automatically detected by the Axel terminal. A barcode reader is treated as a keyboard. See previous chapter.

#### **3.4.4 - Connecting a Mouse**

A USB mouse is automatically detected by the Axel terminal. No specific settings are required.

**Note:** multiple mice (USB and/or PS2) can be used simultaneously.

#### **3.4.5 - Connecting a HUB**

A USB HUB is automatically detected by the Axel terminal. No specific settings are required.

#### **3.4.6 - Connecting a Printer**

##### ***a) Logical Port Attachment***

When a USB printer is connected for the first time to the Axel terminal a logical port is associated. Four logical ports are available: Usb1, Usb2, Usb3 and Usb4.

The associated logical ports are listed in the menu **[Configuration]-[Ports]-[USB Logical Ports]**. To get information of a USB printer, select its logical port and press <Enter>. For example:

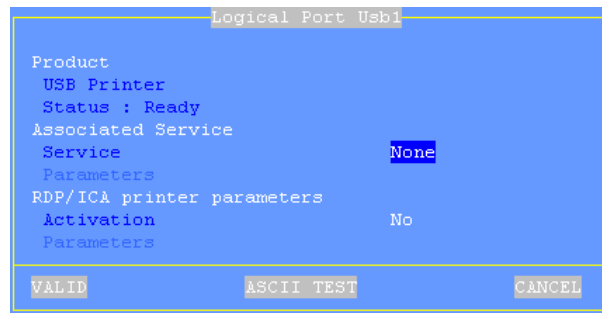

This association is maintained even if the printer is powered off, disconnected or connected to the other USB port.

Releasing a logical port is a manual operation (see Chapter below 'Releasing a Logical Port').

### ***b) Setting-Up***

The USB printer set-up procedure is the same as a serial or parallel printer.

For more information, see Chapter 3.5.2 and the following.

### ***c) Releasing a Logical Port***

A logical port must be manually released. This operation can be performed only when the USB device is no longer connected.

In the menu **[Configuration]-[Ports]-[USB Logical Ports]** select the logical port and press <Enter>. The following box is displayed:

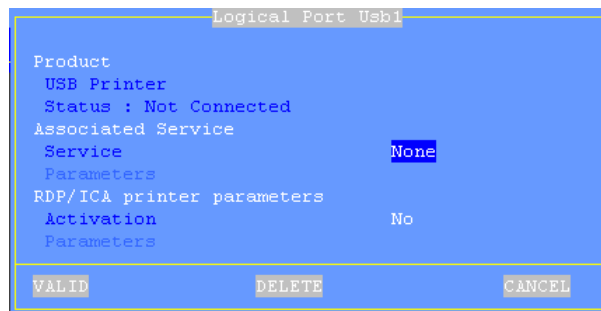

Select the **[DELETE]** button to release the logical port.

The released logical port is removed from the list of the associated ports and is now available for the next USB device.

### **3.4.7 - Connecting a USB-RS232 Adaptor**

#### ***a) Overview***

A USB-RS232 adaptor is normally a cable with USB connector at one end and one or more serial connectors (DB9 or DB25) at the other end. This allows serial devices to be connected when no native serial ports are available.

This technology is sometimes embedded in USB devices. For example touch screens or card readers. These devices have a USB connector but are based on serial technology and are seen as serial ports.



### b) Configuration

A logical USB port is allocated to the USB-RS232 adaptor. (See attaching and releasing operations in the Chapter 3.4.6). For example:



This USB logical port allows the adaptor to be configured: line parameters (baud rate, format...), service and RDP/ICA redirection. For more information see Chapter 3.5.1.

### 3.4.8 - Connecting a Touch Screen

A USB touch screen may be seen by the terminal:

- Either as a pointer device
- Or as an USB-RS232 adaptor. In this case a logical USB port is automatically created (see Chapter 3.4.7).

In both cases, to set-up the touch screen, select the menu **[Configuration]-[General]-[Miscellaneous]**. For more information see Chapter 3.2.2.

### 3.4.9 - Connecting a Mass Storage Device

**Note:** only available with the firmware option MSC.

Most USB mass storage devices fall in one of the categories below:

- memory sticks,
- hard drives,
- CD/DVD readers,
- floppy disks,
- memory card readers,
- digital cameras.

The main difference between these devices is the type of file system (i.e the format in which the data is stored).

**IMPORTANT:** only mass storage devices formatted in FAT12, FAT16, FAT32 and ISO9660 are supported.

For your information the following table lists the most common file systems for each device type (√: supported by a PC or Axel, ○: supported only by a PC):

| USB Mass Storage Device | FAT | NTFS | exFAT | ISO 9660 | UDF | PIMA | Other |
|-------------------------|-----|------|-------|----------|-----|------|-------|
| Memory Sticks           | √   | ○    | ○     |          |     |      |       |
| Hard Drive              | √   | ○    | ○     |          |     |      |       |
| CD/DVD Readers          |     |      |       | √        | ○   |      |       |
| Floppy Disk             | √   |      |       |          |     |      |       |
| Digital Cameras         | √   |      |       |          |     | ○    | ○     |
| Memory Card Readers     | √   |      |       |          |     |      |       |

File systems generally used on most common storage devices

Mass storage devices must be setup at two levels:

- General: see Chapter 3.2.4
- Per Session: see Chapters 5.1.5 and 5.2.6

**Note:** The status line (see Chapter 3.6.2) gives an indicator showing when the device is being accessed

**It's strictly forbidden to remove a device currently in use as the file system could be damaged and the integrity of the storage device lost.**

**3.4.10 - Connecting a Smartcard Reader**

**Note:** only available with the SCA firmware option.

This function is designed for **PC/SC-compliant** smartcard readers. Two readers are supported by the Axel terminal:

- CCID readers,
- Aladdin eToken.

**Note:** Some "non-PC/SC" readers are also supported. This is achieved with the RDP/ICA COM port redirection (or by the tty protocol for Unix/Linux). In this case RS232 devices or USB-RS232 devices must be used (see Chapter 3.4.7).

For the PC/SC devices, a "reader store" is maintained by the terminal. This store is accessed by the **[Configuration]-[Advanced]-[Smartcard Readers]** menu:



A reader is automatically added to the store when being connected for the first time. Up to four readers can be stored. To consult or change reader characteristics select the entry and press <Space>. A dialog box as shown is displayed:



Smartcard reader parameters are:

- **Reader ID:** this value can't be modified. It's composed by the "Manufacturer ID" and "Product ID".

- **Vendor Name:** character string sent back by the terminal when a SCardGetAttrib (option SCARD\_ATTR\_VENDOR\_NAME) command is issued by a Windows PC/SC application.
- **IFD Type:** character string sent back by the terminal when a SCardGetAttrib (option SCARD\_ATTR\_VENDOR\_IDF\_TYPE) command is issued by a Windows PC/SC application.
- **Smartcard Reader Registration:** generally a reader must be attached to the terminal to be enumerated by a PC/SC application (SCardListReaders command). Some readers have to be listed even when they are not attached (for example a token - reader and smartcard are integrated in a memory stick). This parameter allows the method to be selected: dynamic or persistent.

The **[DELETE]** allows this store entry to be deleted.

The use of a smartcard reader is enabled/disabled per session. See Chapters 5.1.5 and 5.2.6.

#### **3.4.11 - Connecting a USB Audio Device**

The USB audio device is automatically detected by the Axel terminal.

The use of an audio device is enabled/disabled per session. See Chapters 5.1.5 and 5.2.6.

#### **3.4.12 - Listing Connected USB Devices**

To list all connected USB devices (supported or not) select the menu **[Diagnostic]-[USB]**. For more information see Chapter 9.4.

## 3.5 - SETTING AUXILIARY AND LOGICAL PORTS

Three types of ports are available for peripheral devices:

- **Auxiliary ports:** one parallel port, two native serial ports (Aux1 and Aux2) and USB-serial devices (Aux3...).
- **USB logical ports:** a USB logical port is automatically created when a USB printer is connected. Four USB logical ports are available (see Chapter 3.4.6).
- **Network Printers:** a TCP logical port (Net1 and Net2) allows a network printer (or a network print server) to be addressed in the same way as a local printer.

The AX3000 (auxiliary and logical) ports can be accessed in various ways:

- By a network service (lpd, tty, prt5250, etc). The management of the ports is independent of the active screen session.
- By an RDP or ICA session (see Chapter 5).
- By escape sequences (transparent mode or embedded printing). This provides compatibility with applications designed for serial terminals.

### 3.5.1 - Setting Up the Ports

This chapter covers selecting, setting up and choosing the network service for each port. (Also see Chapter 3.5.2)

**Note:** within the dialog boxes the **[ASCII TEST]** button verifies communication between the AX3000 port and the connected device. This test works in all port configurations.

**Warning:** if ASCII format is not supported by the printer, the banner won't be displayed.

#### **a) Setting Serial Ports**

**Note:** a serial port is:

- A native serial port (Aux1 and Aux2 for models 65 and 75).
- A USB-serial device (USB/RS232 adaptor, touch screen, card reader...)

Select the **[Configuration]-[Ports]-[Auxiliary Ports]-[AuxX]** dialog box to configure each auxiliary serial port:

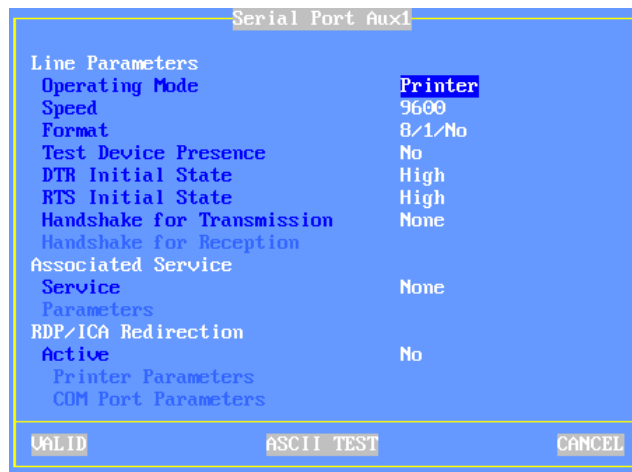

These parameters are:

- **Operating Mode:** four modes are available:
  - **Printer:** data flow takes place one way only (from the AX3000 to the serial peripheral device). However handshaking between the peripheral and the AX3000 is performed.
  - **Bi-directional Device:** Used to control peripherals such as bar code readers, touch screens, scales etc
  - **ASCII to EBCDIC:** this mode allows ASCII data received by the auxiliary port to be converted to EBCDIC (AS/400) format and be placed in the keyboard buffer. This is useful for connecting PC based peripherals (scanners, scales, etc) to an AS/400 application.
    - Note:** the 'associated service' must be set to 'none' and this port must be set as the AX3000 default auxiliary port (select the [Configuration]-[General]-[Miscellaneous] menu).
- **Aux. Command** (only for "ASCII to EBCDIC" mode): an ASCII character string may be sent to the serial device. This is done by pressing the "Send Aux. Command" keystroke. (AltGr-F2 by default)  
Example: requesting weight data from scales.

- **Speed:** selected from a list (from 300 to 115,200 bits per second).
- **Format:** data format is selected from a list: data length (7 or 8 bits), stop bit and parity (none, odd or even).
- **Test Device Presence:** the CTS signal can be used by the AX3000 to detect the peripheral's presence.
- **DTR Initial State:** select 'high' or 'low'.
- **RTS Initial State:** select 'high' or 'low'.
- **Handshake for Transmission:** handshake used by the peripheral to control the AX3000's data flow.
- **Handshake for Reception** (available only in bi-directional mode): handshake used by the AX3000 to control the peripheral's data flow.
- **Associated Service** (ldp, prt5250, tty...): see Chapter 3.5.2 and following.
- **RDP/ICA Redirection:** see Chapter 5.

#### b) Setting the Parallel Port

Select the **[Configuration]-[Ports]-[Auxiliary Ports]-[Parallel]** dialog box to configure the parallel port:

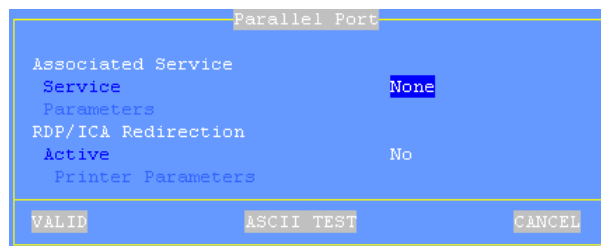

The dialog box parameters are:

- **Associated Service** (ldp, prt5250, tty...): see Chapter 3.5.2 and below.
- **RDP/ICA Redirection:** see Chapter 5.

#### c) Setting USB Logical Ports

Select the **[Configuration]-[Ports]-[USB Logical Ports]-[UsbX]** dialog box to configure a USB logical port.

**Note:** a USB logical port can be associated with a printer or a USB-RS232 adaptor.

Example of a dialog box for a USB printer:



Example of a dialog box for a USB-RS232 adaptor:



The dialog box parameters are:

- **Line Parameters** (USB-RS232 adaptor only): see the serial ports Chapter.
- **Associated Service** (ldp, prt5250, tty...): see Chapter 3.5.2 and below.
- **RDP/ICA Redirection**: see Chapter 5.



#### d) Setting Network Printers

Select the **[Configuration]-[Ports]-[Network Printers]-[NetX]** dialog box to configure TCP logical ports:

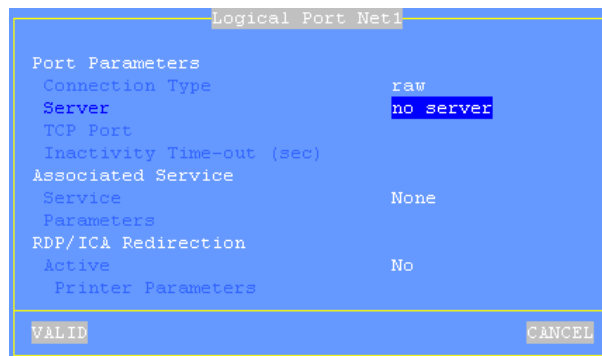

The following parameters can be set:

- **Connection Type:** always 'raw'
- **Server:** press <Space> to select the server from a list.
- **TCP Port:** numeric identifier of the connection. The default value is 2048.
- **Inactivity Time-out (sec):** the session is automatically disconnected after this inactivity delay.
- **Associated Service** (ldp, prt5250, tty...): see Chapter 3.5.2 and below.
- **RDP/ICA Redirection:** see Chapter 5.

#### 3.5.2 - Connecting a Printer

This chapter describes the set-up for an LPD printer attached to the AX3000.

LPD is a universal network printing protocol supported by all operating systems. Often there may be a better protocol to use, for example:

- Prt5250: specific for OS/400 (see Chapter 6.3),
- Prt3270: specific for S/390 (see Chapter 7.3),
- tty: specific for Unix/Linux (see Chapter 5.3),
- RDP or ICA redirection: dedicated to Windows (see Chapter 5.1.5 and 5.2.6).

The embedded LPD print server allows the remote printer to be accessed as a standard system printer.

An LPD printer requires three parameters:

- The AX3000's IP address or FQDN name if DHCP/DNS is used,
- An identifier for the auxiliary port (user selectable character string),
- An optional filter to pre-process the file before printing (but generally this processing is done by the operating system level).

To set the LPD service on a port, select the **[Configuration]-[Ports]-[xxx]-[yyy]** dialog and enter the following parameters:

- **Service:** select lpd.
- **Parameters:** press <Space> to access the following dialog box:

- **Printer Port Name:** this is the port identifier. Sometimes the same name is used for the printer at the operating system level.
- **NL=CR+NL Filter:** The line feed character 0x0A can be mapped to carriage return + line feed 0x0D 0x0A,
- **Enhanced parameters:** see Appendix A.10.3,
- **Pre-print String:** character string sent before the print job.
- **Post-print String:** character string sent after the print job (for example "\0C" is a form feed)

**Note 1:** If "Choose Portrait/Landscape" is enabled (see Appendix A.10.2), the parameter "**Pre-print String**" is replaced by the two parameters "**Portrait Pre-print String**" and "**Landscape Pre-print String**".

**Note 2:** if a serial port is used for printing, set the operating mode to 'Printer'.

For more information about lpd printers, refer to the chapter related to your operating system in this manual.

### 3.5.3 - Connecting a Serial Terminal

Two serial terminals can be attached to the AX3000's serial ports. These serial terminals communicate with the target server(s) using the AX3000's embedded telnet service.

To configure the telnet service for the chosen serial port, select the **[Configuration]-[Ports]-[xxx ]-[yyy]** dialog and enter the following parameters:

- **Service:** select telnet.
- **Parameters:** press <Space> to access the following box:

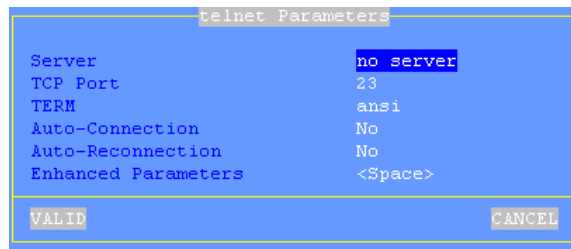

|                     |           |
|---------------------|-----------|
| Server              | no server |
| TCP Port            | 23        |
| TERM                | ansi      |
| Auto-Connection     | No        |
| Auto-Reconnection   | No        |
| Enhanced Parameters | <Space>   |

VALID CANCEL

- **Server:** name of the server selected from a menu (see Chapter 3.1.3).
- **TCP Port:** numeric identifier of the telnet service on the target server. (Default value is 23).
- **TERM:** the value of this variable is 'negotiated', between the server and the AX3000.
- **Auto-Connection:** if this parameter is set to 'yes', the connection will be automatically established when the AX3000 is powered-up. Alternatively the user can press any key on the serial terminal keyboard to initiate the connection.
- **Auto-Reconnection:** if this parameter is set to 'yes' a new connection is automatically established after a disconnection. If set to 'no' the user can press any keyboard key to establish a new connection.
- **Enhanced parameters:** see Appendix A.10.3.

**Note:** the serial auxiliary port used must be configured for 'bi-directional' operating mode.

### **3.5.4 - Connecting other Peripherals**

The Unix/Linux tty service provides bi-directional control of the device.

**Note:** only the two serial auxiliary ports are bidirectional. For other ports (parallel and logical ports) the tty service acts as a unidirectional service.

To set the tty service on the port, enter the following parameters in the **[Configuration]-[Ports]-[xxx]-[yyy]** dialog box:

- **Service:** select tty.
- **Parameters:** press <Space> to access the following box:

| tty Parameters                                                             |           |
|----------------------------------------------------------------------------|-----------|
| Server                                                                     | no server |
| TCP Port                                                                   | 2048      |
| Auto-Reconnection                                                          | No        |
| Enhanced Parameters                                                        | <Space>   |
| <input type="button" value="VALID"/> <input type="button" value="CANCEL"/> |           |

- **Server:** name of the server selected from a menu (see Chapter 3.1.3).
- **TCP Port:** numeric identifier of the tty service on the target server. The TCP Port default value is 2048.
- **Auto-Reconnection:** if this parameter is set to 'yes', a new connection is automatically established after a disconnection. Otherwise, the AX3000 must be power-cycled.
- **Enhanced parameters:** see Appendix A.10.3.

**Note:** Axel provides a **Unix/Linux utility** called axtty by which pseudo-devices (/dev/ttyx) may be linked to the AX3000 serial ports. The AX3000 ports appear as local UNIX '/dev/xxx' ports. For more information, see Chapter 5.4.

### **3.5.5 - Using a Serial Port as the Main Port of a Session**

A screen session can be associated with a serial port. This session now connects as a serial dumb terminal.

Serial and TCP/IP screen sessions can be used at the same time.

For more information see Chapter 8.1.2 (sub-section d).

**3.5.6 - Other Uses**

**a) Using rtty**

With the rtty service, the AX3000 acts as a server. The AX3000 "listens" on a given TCP port. Then, a connection can be established from a Windows or Unix box to send or received data.

**Note:** the rtty service can also be used with the Axel daemon (axttyd) under UNIX (see Chapter 8.4).

To set the rtty service on the port, enter the following parameters in the **[Configuration]-[Ports]-[xxx]-[yyy]** dialog box:

- **Service:** select rtty.
- **Parameters:** press <Space> to access the following box:

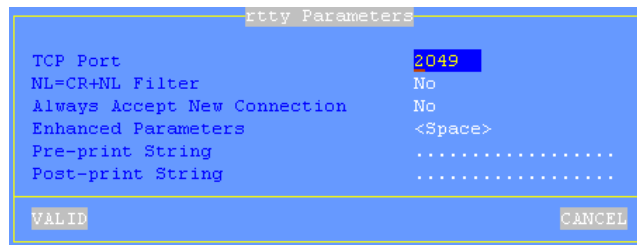

- **Port TCP:** numeric value associates to this auxiliary port.
- **NL=CR+NL Filter:** The line feed character 0x0A can be mapped to carriage return + line feed 0x0D 0x0A,
- **Always Accept New Connection:** set the AX3000 behavior when an rtty connection is already established and a second connection rtty is received.
- **Enhanced parameters:** see Appendix A.10.3.
- **Pre-print String:** character string sent before the printing.
- **Post-print String:** character string sent after an the printing (for example "\0C" is a form feed)

**Note:** If "Choose Portrait/Landscape" is enabled (see Appendix A.10.2), the parameter "**Pre-print String**" is replaced by the two parameters "**Portrait Pre-print String**" and "**Landscape Pre-print String**".

**b) Using the rsh Command to Print**

The embedded rcmd service allows printing with the rsh command (or rcmd command, according to the operating system used).

To set the rcmd service on the required auxiliary port, select the rcmd service from the **[Configuration]-[Ports]-[xxx]-[yyy]** dialog box. Then enter the name of the associated printer port.

For more information about the rsh command, refer to Chapter 5.3.3.

**c) Using printd Legacy Service**

The printd service is a legacy printer service used in conjunction with the UNIX axconf utility. It is supported to maintain backward compatibility, but lpd or tty services should always be used in preference.

**3.6 - TERMINAL LOCAL DESKTOP**

The terminal local desktop configuration provides:

- The session manager settings,
- The status line settings,
- Hot keys to flip between sessions.

Select the **[Configuration]-[Sessions]-[Local Desktop]** menu:



### **3.6.1 - Session Manager**

When no session is connected a specific screen is displayed. This is the 'session manager'.

Two styles are available for this session manager:

- Classic: legacy text mode,
- Desktop: user-friendly display with icons and status line.

Selecting a background color allows the "Desktop" session manager to be customized.

The use of the session manager is described in Chapter 4.1.

### **3.6.2 - Status Line**

An optional status line can be enabled. It's located on the bottom of the screen. This status line allows:

- The current session to be easily identified,
- The other connected session(s) to be easily seen,

- Switching sessions by clicking the label with the mouse.

A label (11-character string) is associated with each session. This label is by default the name of the connected server but it can be user-defined to any value. The label of the current session is displayed in reverse video mode. A session label is preceded by an indicator (circle):

- The circle is empty: the session is declared but not connected.
- The circle is filled in green: the session is connected

**Note:** when a mass storage device is currently in use, a colored indicator is displayed on the right (green: read in progress, red: write in progress). **It's strictly forbidden to remove a USB device when currently in use.**

### **3.6.3 - Multi-Session Keystroke**

The keystrokes to move from one session to another can be customized: A session keystroke is composed by:

- **An introducer:** this combination is selected through a list:

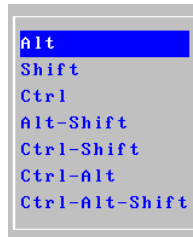

- **A session key:** this key must be different per session.



### 3.7 - OTHER FUNCTIONS

Less-used functions are available through the **[Configuration]-[Advanced]** menu:

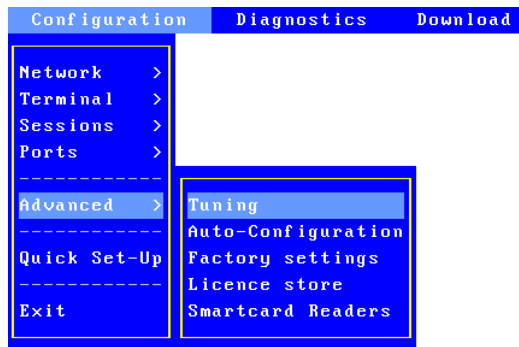

#### 3.7.1 - Tuning

This box offers special terminal operating parameters. Usually the default values are suitable.

For more information see Appendix A.10.2.

#### 3.7.2 - Auto-Configuration

The Auto-Configuration function lets a terminal check if new firmware and/or new configuration files are available.

This function is automatically started when the terminal is powered-on for the very first time. See Chapter 2.2.

Additionally this function can also be set to run each time the terminal boots:

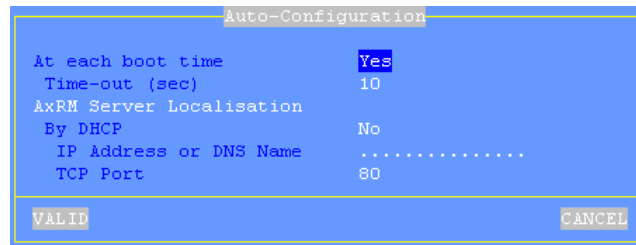

The screenshot shows a terminal window titled "Auto-Configuration" with the following settings:

|                          |       |
|--------------------------|-------|
| At each boot time        | Yes   |
| Time-out (sec)           | 10    |
| AxRM Server Localisation |       |
| By DHCP                  | No    |
| IP Address or DNS Name   | ..... |
| TCP Port                 | 80    |

At the bottom of the window, there are two buttons: "VALID" on the left and "CANCEL" on the right.

The 'time-out' parameter is the maximum number of seconds allowed for the terminal to load a new firmware/configuration. If nothing is received in this time the terminal boots up using existing current settings.

Two methods are available for the terminal to locate the AxRM server (IP address and TCP port):

- **Static**: the IP address (or the name) and the TCP port are entered
- **Dynamic** (only if DHCP is already used to get the terminal IP address): the IP address and TCP port are given through the DHCP protocol (see Chapter 2.2.3 for more information).

For more information about Auto-Configuration stages, refer to Chapter 2.2.

### **3.7.3 - Factory Settings**

This allows, after confirmation, terminal factory settings to be reloaded. **The current configuration is lost.** See Appendix A.10.1.

### **3.7.4 - License Store**

This allows the Microsoft license tokens to be listed. In event of problems the license store can be cleared. See Chapter 5.6.5.

### **3.7.5 - Smartcard Readers**

This allows the smartcard readers actually 'known' by the terminal to be listed. For more information, see Chapter 3.4.10.

**- 4 -**  
**USING THE AX3000**

*This chapter covers use of the AX3000.*

## 4.1 - SWITCHING ON THE AX3000

The following operations are performed when the terminal is turned-on:

- **Boot:** initialization, network detection...
- **Auto-configuration** (optional): checks over the network if a new firmware/configuration is available. If yes the terminal reboots again for the new firmware/configuration to take effect (for more information see Chapter 2.2)
- **Auto-Connection:** some connections may be opened automatically:
  - Screen sessions (if the 'auto-connection' parameter is set to 'yes'),
  - Auxiliary port sessions: if the associated service is a client service (tty, telnet or prt5250) and if the 'auto-connection' parameter is set to 'yes'.

If multiple screen sessions are auto-connected, the first active screen session is displayed.

- **Session Manager:** if no screen session is connected, the Session Manager is displayed (see Chapter 3.6). Two modes are available:
  - Classic mode
  - Desktop mode

The following chapter covers the session manager modes.

#### 4.1.1 - Session Manager: Classic Mode

This is the appearance of the classic mode:

```
-- AXEL Ultra Thin Client --  
www.axel.com  
  
Session Manager  
  
<Alt F1> -> session 1 TSE      w2k3  
<Alt F2> -> session 2 5250    as400  
<Alt F3> -> session 3 5250    as400  
<Alt F4> -> session 4 5250    as400  
  
Copyright AXEL  
  
00:10:34:20:10:03  
FK19.BV31b/TCP/FR/0632a:STD
```

The following information is displayed for each session:

- The associated keystroke. For example <Alt F1>
- The session label. For example "1 TSE" or "2 5250".
- The server.

To open a session the user presses the associated keystrokes.

### **4.1.2 - Session Manager: Desktop Mode**

This is the appearance of the Desktop Mode:

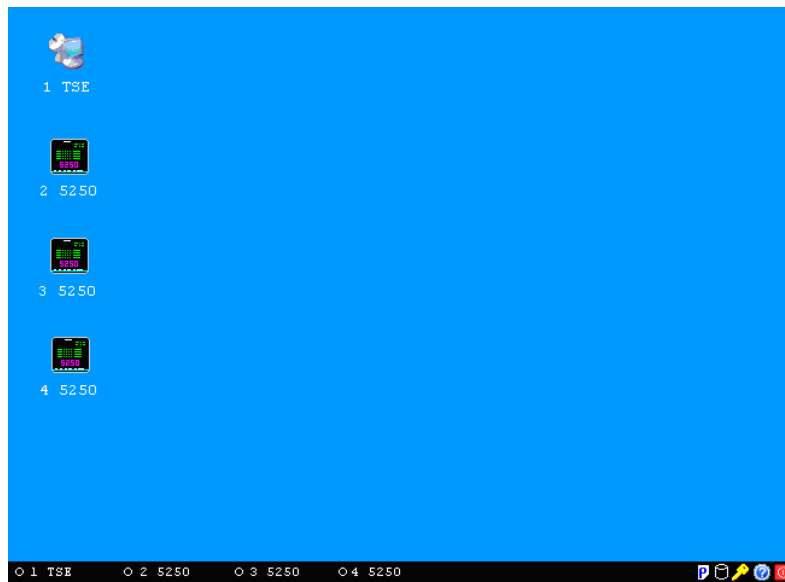

The following information is displayed for each session:



- An icon
- The indicator and the session label. For example "1 TSE" or "2 5250".

**Note:** whatever the status line settings, with the session manager the status line is always displayed.





Possible actions:

- Click the icon to open a session. (The associated keystroke is also available.) See Table 1.
- Click a status line icon. See Table 2.

**Table 1** - session type icons

|                                                                                   |                                                                                   |                                                                                   |                                                                                    |                                                                                     |
|-----------------------------------------------------------------------------------|-----------------------------------------------------------------------------------|-----------------------------------------------------------------------------------|------------------------------------------------------------------------------------|-------------------------------------------------------------------------------------|
|  |  |  |  |  |
| TSE                                                                               | Citrix<br>Published App.<br>Published Svr.                                        | Citrix<br>Published App.<br>Desktop                                               | Virtual<br>Desktop<br>(XEN)                                                        | Virtual<br>Desktop<br>(VMWARE)                                                      |
|  |  |  |  |                                                                                     |
| VNC                                                                               | 5250                                                                              | 3270                                                                              | Text<br>Emulation                                                                  |                                                                                     |

**Table 2** - status line icons

|                                                                                     |                                                              |
|-------------------------------------------------------------------------------------|--------------------------------------------------------------|
|  | Turning off - See Chapter 4.5                                |
|  | Getting terminal information (Firmware/Hardware)             |
|  | Disconnecting the current session. See Chapter 4.2.2.        |
|  | USB drive status. Only displayed if a USB drive is attached. |
|  | Set Portrait/Landscape mode - See Appendix A.10.2            |

## 4.2 - USING MULTIPLE SESSIONS

AXEL terminals provide **multiple and concurrent connections**. This feature allows simultaneous access to multiple hosts and applications.

### 4.2.1 - Opening and Switching Sessions

Opening or switching sessions can be done through:

- **The keyboard:** press <Alt><Fx>. These default keystrokes can be changed (see Chapter 3.6.3).
- **The mouse:** click left:
  - With the session manager (desktop mode): click onto a session icon.

- With the status sine: click the session label. (The status line must be enabled - see Chapter 3.6.2 - and the mouse be supported by the current session).

**Note:** if the session is 'host free', a dialog box is displayed. The following parameters are required:

- **Connection Type:** read only information.
- **Host:** press <Space> to select the host
- **TCP Port:** the default value is protocol dependent

#### **4.2.2 - Disconnecting Sessions**

A session can be disconnected by one of following ways:

- A system command (ie logging off the server)  
Example: under Unix, exit (or <Ctrl><D>),
- **<Ctrl><Alt><D>**. This keystroke is locally processed by the AX3000 and works regardless the operating system.
- The status line "key" icon

If the user closes the current session (<Ctrl><D> in UNIX) the behavior of the terminal depends on how the '**auto-reconnection**' parameter is set for the current session.

If this parameter is set to '**yes**', a new connection is immediately and automatically established within the current session.

If this parameter is set to '**no**', the AX3000 displays the first of the remaining active sessions. If there are no remaining active sessions (for example, because the last active view has been disconnected), the session manager is displayed.

### **4.3 - LOCKING THE SCREEN**

For security reasons, it might be useful for the AX3000 operator to lock the screen rather than logging out.

**Note:** the lock screen means the AX3000 screen is blanked but the current sessions are still connected and active. There is no way to enter the AX3000



Set-Up or to switch the session. The only way to regain control is to enter the proper password.

The lock screen feature is associated with the screen saver function and must be enabled through the AX3000 Set-Up (see Chapter 3.2.2).

Two methods are available to lock a screen:

- **Automatically:** when the terminal is idle (keyboard or screen) for a certain time, the AX300 blacks out the monitor display. The display is automatically restored as soon as a key is pressed. A dialog box allowing the screen to be unlocked after password is entered is displayed.
- **Manually:** the <Ctrl><Alt><S> keystroke allows the screen to be locked immediately.

An unlock-screen dialog box is displayed. Two operations are possible:

- Entering the password to unlock the screen. Two passwords can be used: the screen saver password and the set-up password (see Chapter 3.2.7).
- Resetting the AX3000. If the password is forgotten, the only way is selecting the [Shutdown] button. After power-cycling it, the AX3000 administrator will be able to modify or remove the screen saver password.

**Note:** For the highest level of security we recommend setting the terminals 'Set-Up' password. (See Chapter 3.2.7)

## 4.4 - "COPY/PASTE" FUNCTION

The terminal offers a "Copy/Paste" function which operates either in the current session or between different sessions.

For example, text can be copied from a 5250 session and pasted to a Windows session.

### **a) Copy**

From a Windows Session (RDP or ICA):

Use the standard 'Copy' function. For example <Ctrl><C>

From a VNC Session:

The 'vnconfig' tool must be run. The copy is simply done by selecting a text zone.

From a Text Session (5250, 3270, ANSI, VT...):

Press **<Ctrl><C>** (with 5250 and 3270 emulations) or **<Ctrl><Alt><C>** (with other emulations) to enter the Copy mode. Use the mouse to select the copy data. Pressing <Enter> validates the selection and the text is copied into a local clipboard. (<Esc> cancels Copy Mode).

**Note:** the Copy function is available only if the mouse is supported by the current session.

Note: We are unable to use the "standard" of cont c as this is already used for another function within Unix/Linux

**b) Paste**To Windows Session (RDP or ICA):

Use the standard 'Paste' function. For example <Ctrl><V>

To a VNC Session:

The 'vnconfig' tool must be run. Select 'Paste' in the contextual menu of the Linux software.

To a Text Session (5250, 3270, ANSI, VT, WYSE...):

Press **<Ctrl><V>** (with 5250 and 3270 emulations) or **<Ctrl><Alt><V>** (with other emulations) to paste the contents of the local clipboard.

**Note:** for the 5250 and 3270 sessions, a <Field Exit> function is sent at the end of each line contained in the clipboard.

## 4.5 - TURNING OFF THE AX3000

A careful check should be made before turning off the TCP/IP AX3000 if TCP/IP connections are active. The operating system cannot detect if a TCP/IP device is turned-off, so the current TCP/IP connections remain active as far as the server is concerned - resulting in various potential issues.

Under Unix it is advisable not to turn off the TCP/IP AX3000 when a login prompt is displayed (something which is commonly done with serial UNIX terminals). This is because a telnet connection has been opened and will then become an orphan process. The following examples illustrate how the TCP/IP AX3000 differs from a conventional dumb terminal:

- If the 'auto-reconnect' parameter is set to 'yes', a stable stage cannot be reached on the AX3000. New telnet connections will repeatedly be opened.
- Under OS/400, it is impossible to exit the login stage, because there is no way to close the current telnet session.

To allow graceful shutdown, an AX3000 shutdown function is available. Press **<Ctrl><Alt><Del>**.

A dialog box allows the next step to be selected:

- [SHUTDOWN] button
- [REBOOT] button

After selection, all active connections (screen and auxiliary port) are closed.

For the "Shutdown" choice, a few seconds later, the user is informed that the AX3000 may be turned off.

## 4.6 - AX3000 HOT-KEYS

The AX3000 hot-keys are listed in the following table. (These hot-keys are locally processed by the AX3000 and independent of emulation).

| PC-Keyboard                               | 5250-Keyboard                             | Action                                                        |
|-------------------------------------------|-------------------------------------------|---------------------------------------------------------------|
| <Ctrl><Alt><Esc>                          | <Rest><Alt><Esc>                          | Enters the AX3000 Set-Up                                      |
| <Alt><Fx>                                 | <Alt><Fx>                                 | Switches session (these hot-key can be modified)              |
| <Alt><+>                                  | <Alt><+>                                  | Switches to next session                                      |
| <Alt><->                                  | <Alt><->                                  | Switches to previous session                                  |
| <b>&lt;Ctrl&gt;&lt;Alt&gt;&lt;S&gt;</b>   | <b>&lt;Rest&gt;&lt;Alt&gt;&lt;S&gt;</b>   | Locks the screen.                                             |
| <Ctrl><Alt><Pause>                        | <Rest><Alt><Pause>                        | Sends a break code.<br><b>Note:</b> only for telnet protocol. |
| <Ctrl><Alt><Prt Scr>                      | <Rest><Alt><Prt Scr>                      | Performs a screen dump to the default auxiliary port.         |
| <b>&lt;Ctrl&gt;&lt;Alt&gt;&lt;D&gt;</b>   | <b>&lt;Rest&gt;&lt;Alt&gt;&lt;D&gt;</b>   | Closes the current session                                    |
| <b>&lt;Ctrl&gt;&lt;Alt&gt;&lt;K&gt;</b>   | <b>&lt;Rest&gt;&lt;Alt&gt;&lt;K&gt;</b>   | Changes the keyboard type (PC√AS/400)                         |
| <b>&lt;Ctrl&gt;&lt;Alt&gt;&lt;Del&gt;</b> | <b>&lt;Rest&gt;&lt;Alt&gt;&lt;Del&gt;</b> | Shuts down the AX3000.                                        |
| <b>&lt;Ctrl&gt;&lt;Alt&gt;&lt;I&gt;</b>   |                                           | Information about the RDP, ICA or VNC current session.        |
| <b>&lt;Ctrl&gt;&lt;Alt&gt;&lt;X&gt;</b>   | <b>&lt;Rest&gt;&lt;Alt&gt;&lt;X&gt;</b>   | Opens the connection box (see Chapter 9.2)                    |
| <Ctrl><Alt><BackTab>                      | <Rest><Alt><BackTab>                      | Set 'text mode' set-up                                        |
| <Ctrl><C> or<br><Ctrl><Alt><C>            | <Rest><C>                                 | Selects and copies a screen zone (mouse is requested)         |
| <Ctrl><V> or<br><Ctrl><Alt><V>            | <Rest><V>                                 | Paste the text                                                |

**Note:** keystrokes written in bold can be disabled. See Chapter A.10.2, section d).

**- 5 -**  
**INSTALLING UNDER WINDOWS**

*This chapter covers AX3000 installation under Windows*

This chapter describes the operation of the AX3000 in a Windows environment. For more general information please refer to the previous chapters.

The connection to a Windows server can be done either via:

- Microsoft's **RDP protocol**. See Chapter 5.1.
- Citrix's **ICA protocol**. Two connection types are available:
  - To a published server or application. See Chapter 5.2.
  - Through a local desktop (like Nfuse, WEB Interface and Program Neighborhood). See Chapter 5.3.
- A **virtual desktop**. See Chapter 5.4.

These protocols enable a remote graphical display on the AX3000. The image is constructed, maintained and updated within the Windows server.

## 5.1 - RDP SCREEN SESSION

Axel terminals provide an embedded RDP-compatible protocol. The following table shows key features available for each operating system:

|              | Number of colors<br>(bits/pixel)    | Redirection |          |       |
|--------------|-------------------------------------|-------------|----------|-------|
|              |                                     | Printer     | COM Port | Audio |
| NT4-TSE      | 8 bpp                               | -           | -        | -     |
| Windows 2000 | 8 bpp                               | Yes         | -        | -     |
| Windows 2003 | 8 bpp, 15 bpp,<br>16 bpp and 24 bpp | Yes         | Yes      | Yes   |
| Windows 2008 | 8 bpp, 16 bpp and 32 bpp            | Yes         | Yes      | Yes   |

### 5.1.1 - Setting-Up an RDP Session

To set an RDP session, enter the AX3000 Set-Up and select the **[Configuration]-[Sessions]-[Session X]** menu (where X is the session number to be configured). The following box is displayed:

| Session 1 Profile     |           |        |
|-----------------------|-----------|--------|
| Connection Parameters |           |        |
| Session Type          | TSE (rdp) |        |
| Server                | no server |        |
| Connection Properties | <Space>   |        |
| Auto-Logon            | <Space>   |        |
| Session Parameters    |           |        |
| Display Parameters    | <Space>   |        |
| Additional Parameters | <Space>   |        |
| Redirected Resources  | <Space>   |        |
| Bandwidth             | <Space>   |        |
| OK                    | RESET     | CANCEL |

Set the following parameters:

- **Session Type:** select "TSE (rdp)"
- **Server:** press <Space> to select the server from a list
- **Connection Properties:** pressing <Space> displays a dialog box which lets certain connection parameters be changed. See Chapter 5.1.7.
- **Auto-Logon:** press <Space> to set the "Automatic Logon" function and/or the "Auto-Run" function. For more information, see Chapter 5.1.4.
- **Display Parameters:** press <Space> to set display settings (resolution and colors). For more information, see Chapter 5.1.2.
- **Additional Parameters:** pressing <Space> displays a dialog box, which lets certain RDP parameters be changed. For more information, see Chapter 5.1.3.
- **Redirected Resources:** press <Space> to set redirected printers and COM ports. For more information, see Chapter 5.1.5.
- **Bandwidth:** pressing <Space> displays a dialog box, which lets certain parameters be changed. For more information, see Chapter 5.1.6.

**Note:** after saving changes power-cycle the AX3000.

### 5.1.2 - Display Parameters

Within the 'Session Profile' box, select 'Display Parameters' and press <Space>. The following box is displayed:

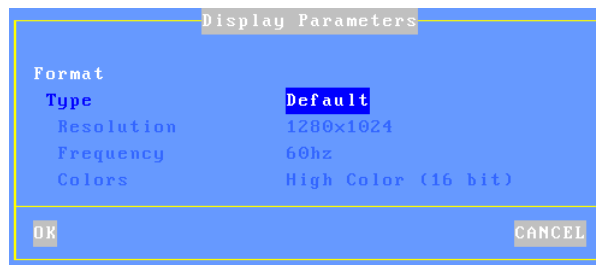

This box allows display settings (resolution, number of colors and frequency) to be set. The availability of these parameters depends of the **Type** value:

- **Default:** these three parameters are issued from general settings (see Chapter 3.2.2). When general settings are modified, these three parameters are automatically updated with new values.
- **Customized:** the three parameters are independent from general settings.

**Note:** the 32bpp value color allows the true-color mode on Windows 2008 (24bpp is not supported by this O.S.).

### 5.1.3 - RDP Additional Parameters

Within the 'Session Profile' box, select 'Additional Parameters' and press <Space>. The following box is displayed:

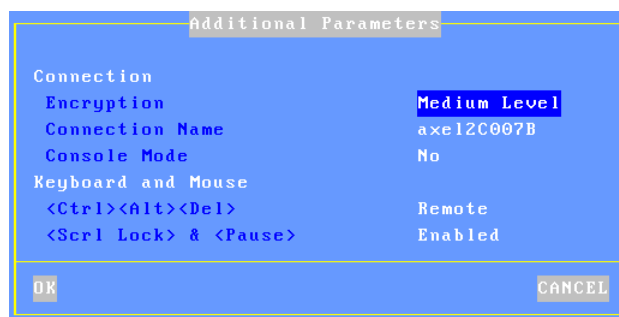



These parameters are:

- **Encryption:** three values of encryption are available. (For more information see Chapter 5.5.1):
  - No: only non-encrypted connections are accepted.
  - Low Level: only one-direction encrypted connections are accepted. (Data sent by Windows is encrypted).
  - Medium Level: both-direction and one-direction encrypted connections are accepted.
  - High Level: only both-direction encrypted connections are accepted.
- **Connection Name:** this character string identifies the AX3000 within the Windows Operating System. By default this name is the terminal name (see Chapter 3.1.1).  
Note: This is not the identifier used by Windows for licensing control. The licensing identifier cannot be changed.
- **Console Mode:** when set to 'yes', the RDP connection will take remote control of the Windows Server main console.
- **<Ctrl><Alt><Del>:** the two modes for this keystroke are:
  - Local: the keystroke is handled by the AX3000 and is used for shutdown the terminal (see Chapter 4.5)
  - Remote: the keystroke is handled by the Windows server (for example opening the task manager).
- **<Scroll Lock> & <Pause>:** enable or disable these two keys

### 5.1.4 - Automatic Logon and Auto-Run

Within the 'Session Profile' box, select 'Login Script' and press <Space>. The following box is displayed:

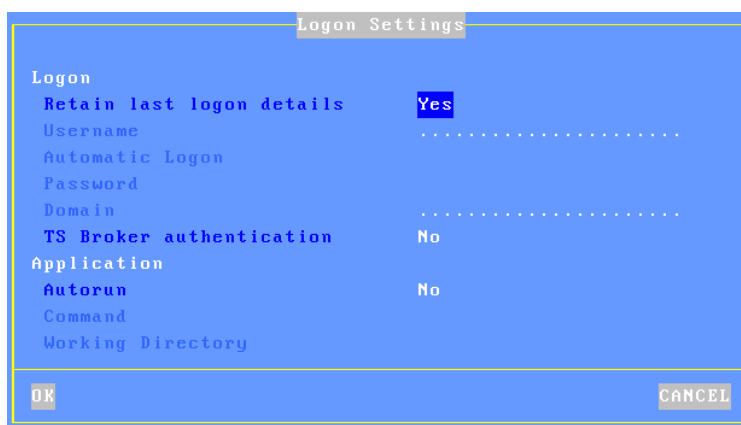

These parameters are:

- **Retain last logon details:** this parameter allows the username and domain fields of the Login screen to be automatically set-up.
- **Username:** default value for the username field of the Login screen.
- **Automatic Logon:** set this parameter to 'Yes' to get an automatic logon. For more information about the auto-login, see Chapter 5.5.2.
- **Password** (available only if 'Automatic Logon' is set to 'Yes'): press <Space> to enter the password.
- **Domain:** this is the default value for the Windows domain field of the Login screen.
- **TS Broker Authentication:** enabling this parameter allows a Windows 2008 server farm to be correctly managed: a local authentication (username/password/domain) must be performed by the terminal.
- **Auto Run:** by default the Terminal Services connection offers a Windows desktop. To automatically launch a program set this parameter to 'Yes' and complete the following fields.
- **Command** (available only if 'Auto-Run' is set to 'yes'): the program path and file name of the program to be launched.  
Example: %SystemRoot%\system32\cmd.exe

- **Working Directory** (available only if 'Auto-Run' is set to 'yes'): sets program working directory.  
Example: D: \

### **5.1.5 - Redirected Resources**

The redirected resources mechanism allows one or more local resources to be 'published' to the Windows server. These resources are available only for the terminal's user. They are created on the Windows server when the connection is established and removed when the session is disconnected.

The following local resources are supported:

- **Printers**: before being redirected each printer must be declared at the 'physical connection port' level. See first sub-section a) then c).
- **COM/LPT ports** before being redirected each port must be declared at the physical port level. See first sub-section b) then c).
- **Mass storage devices**: see sub-section c).
- **Smartcard readers**: see sub-section c)
- **Audio**: see sub-section c)

**Note:** printer redirection requires a Windows 2000 server (minimum). For other resources, a Windows 2003 service is required (except for Audio where a Windows 2008 server is strongly advised).

#### ***a) Declaring a Redirected Printer***

At the RDP/ICA connection time a redirected printer will be automatically added to the Windows spooler. It will be removed when the session disconnects.

Before being redirected an RDP/ICA printer must be declared at the 'physical connection port' level. The available ports are: auxiliary ports (parallel, Aux1 and Aux2), USB logical ports and network printers.

Select the dialog box of the 'Connection port' (menu **[Configuration]-[Ports]-[xxx]**). For example, the Aux1 port:

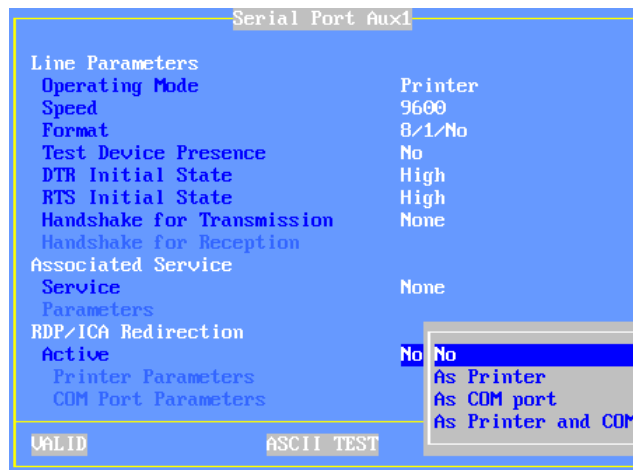

Set the 'Active' parameter to 'As Printer' or 'As Printer and COM'. Then select 'Printer Parameters' and press <Space>. The following box is displayed:

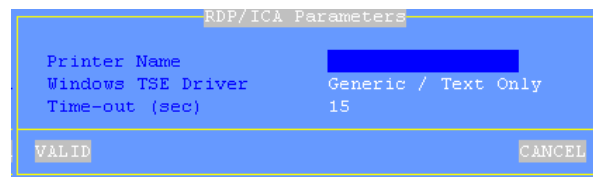

These parameters are:

- **Printer Name:** name of the Windows printer. (User definable)
- **Windows TSE Driver:** printer driver name. It is ESSENTIAL that the value entered here matches the printer driver name exactly as installed on the server. If the match is not exact Windows will not be able to connect the printer to the driver and the printer will not be added to the Windows spooler.
- **Time\_out (sec):** in event of a printer error (no paper, off-line, etc.), this is the delay before the terminal reports the error to Windows.

The printer declaration is completed. For the redirection procedure, consult the

sub-section c).

NOTE: In the event of problems log in as administrator to determine the user profile has correct permission levels

**b) Declaring a Redirected COM/LPT Port**

On an RDP/ICA connection a redirected COM/LPT port will be automatically added to the Windows server resources. It will be removed on disconnection. Maximum two ports can be redirected.

Before being redirected an RDP/ICA COM Port must be declared at the 'physical port' level. The available ports are: auxiliary ports (parallel, Aux1 and Aux2) and USB logical ports.

Select the dialog box of the 'Connection port' (menu **[Configuration]-[Ports]-[xxx]**). For example, the Aux1 port:

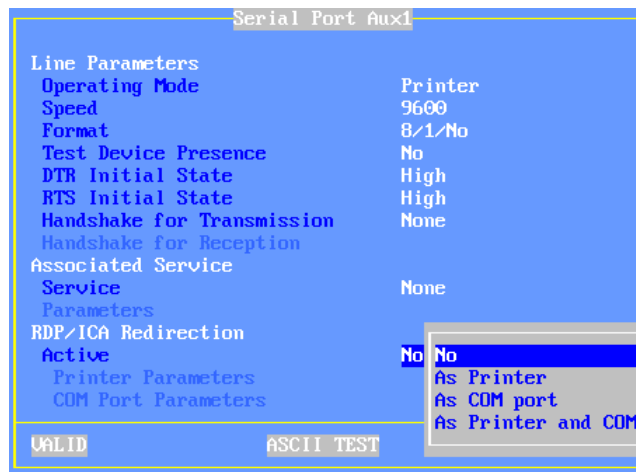

Set the 'Active' parameter to 'As COM port' or 'As Printer and COM'. Then select 'COM Port Parameters' and press <Space>. The following box is displayed:

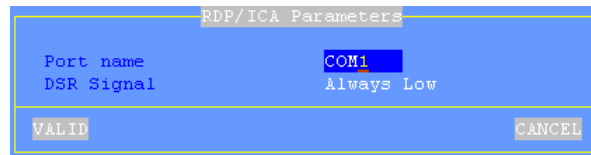

These parameters are:

- **Port Name:** redirect COM port name (from COM1 to COM255).
- **DSR Signal** (only for Aux1 and Aux2): the DSR signal is not supported by the AX3000 native auxiliary ports. This parameter allows the incoming DSR value to be emulated. The possible values are: "Always Low", "Always Up", "Follows CTS" or "Follows CD".

**Note:** for redirecting an LPT port, set the 'Active' parameter to 'As LPT port' or 'As Printer and LPT'. The LPT port settings dialog box only offers to customize the LPT name (LPT1 by default).

The COM port declaration is completed. For the redirection procedure, consult the next sub-section.

### c) Redirecting Resources within the RDP session

To redirect resources within a session select the session profile box (menu **[Configuration]-[Sessions]-[Session X]**). Within this box, select 'Redirected Resources' and press <Space>. The following box is displayed:

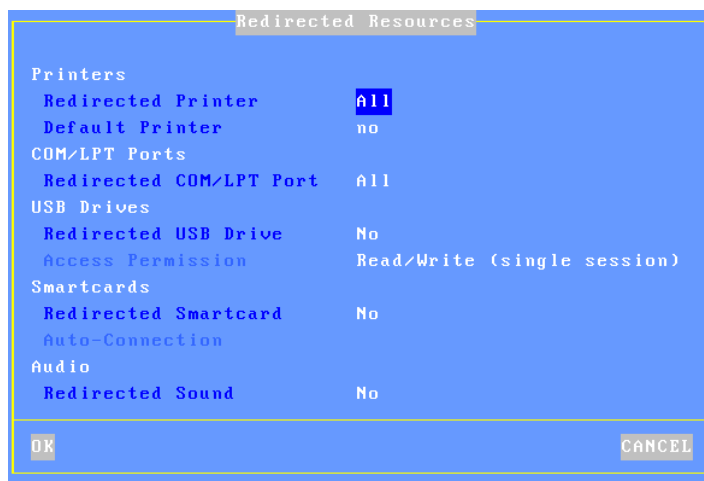

These parameters are:

- **Redirected Printer:** printer(s) are selected through a list. This list is composed by the following items:
  - All
  - None
  - **Printer Name (port):** these are the RDP/ICA printer name(s). This allows the selection of only one printer to be redirected.
- **Default printer:** set (or not) a printer as the default printer.
- **Redirected COM/LPT Port:** COM port(s) are selected through a list. This list is composed by the following items:
  - All
  - None
  - **xxx (port):** these are the COM/LPT port name(s). This allows the selection of only one port to be redirected.
- **Redirected USB Drive:** enable/disable the mass storage device redirection. The 'Access Permission' value reminds the selected mode (see Chapter 3.2.4).

- **Redirected Smartcards:** enable/disable the smartcard redirection.
- **Auto-Connection:** when set to yes, the option allows the ICA session to be automatically established when a smartcard is inserted in the reader.
- **Redirected Sound:** enable/disable the audio redirection.

### 5.1.6 - Bandwidth

Within the 'Session Profile' box, select 'Bandwidth' and press <Space>. The following box is displayed:



These parameters are:

- **Bitmap Cache:** enabling the bitmap cache allows the AX3000 to store images (icon, buttons, etc) locally. This can both improve the AX3000 performance and decrease network traffic.
- **Offscreen Cache:** enabling the offscreen cache allows the AX3000 to store images in a 'non visible' part of the VGA memory. This parameter can be enabled for a single session. This can both improve the AX3000 performance and decrease network traffic.
- **Compress:** this allows Windows to send compressed data. This optimizes bandwidth but in some cases can decrease overall performance. The possible values are "no", "display" or "display and aux. ports".
- **Mouse Traffic:** the options are:
  - All (default): all mouse events (clicks and position) are sent to the server.



- Click: only the click events are sent to the server. This reduces the data flow. But the mouse cursor is not updated in real time. This mode can significantly reduce bandwidth.
- **Mouse Sensitivity:** This setting varies the sample rate of the mouse. If the sensitivity is increased the mouse movement will be more fluid, but also network activity is increased as the sample rate is increased.
- **Audio Quality:** the bandwidth depends on the audio quality. For remote connections prefer a low quality.

The following parameters are only supported when the terminal is connected to a Windows 2003/2008 server. By default, all these features are disabled. To allow a feature set it to "X":

- **Desktop Background:** the AX3000 operator is allowed to select a desktop background.  
Note: the background feature must be also allowed by the Windows server. See Chapter 5.1.2, Sub-Chapter d.
- **Show contents of window while dragging:** the AX3000 operator can choose to display the contents of windows while resizing or dragging.
- **Menu and window animation:** the AX3000 operator is allowed to select the animation function.
- **Themes:** the AX3000 operator is allowed to select a theme (i.e. a desktop appearance) other than the Windows Classic Theme.

### 5.1.7 - Connection Properties

Within the 'Session Profile' box, select 'Connection Properties' and press <Space>. The following box is displayed:

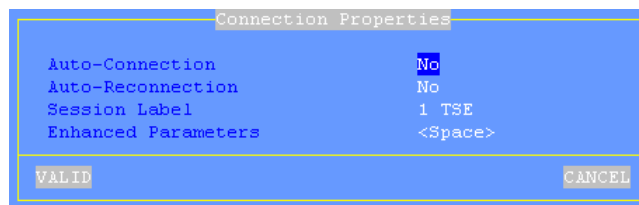

These parameters are:

- **Auto-Connection:** if this parameter is set to 'yes', the connection will be automatically established when the AX3000 is powered. Otherwise, the user can press <Alt><Fx> to establish the connection.
- **Auto-Reconnection:** if this parameter is set to 'yes', a new connection is automatically established after a disconnection. Otherwise, the user can press <Alt><Fx> to establish a new connection.
- **Session Label:** this character string (11 characters max.) is used to identify the session within the session manger or in the status line.
- **Enhanced parameters:** see Appendix A.10.3.

## 5.2 - ICA SCREEN SESSION

The "Axel ICA-compliant" protocol allows Axel terminals to be connected to Metaframe XP, Presentation server 4, Presentation server 4.5 and Xen App 5.

### 5.2.1 - Setting-Up an ICA Session

To set the ICA session, enter the AX3000 Set-Up and select the **[Configuration]-[Sessions]-[Session X]** menu (where X is the session number to be configured). The following box is displayed:

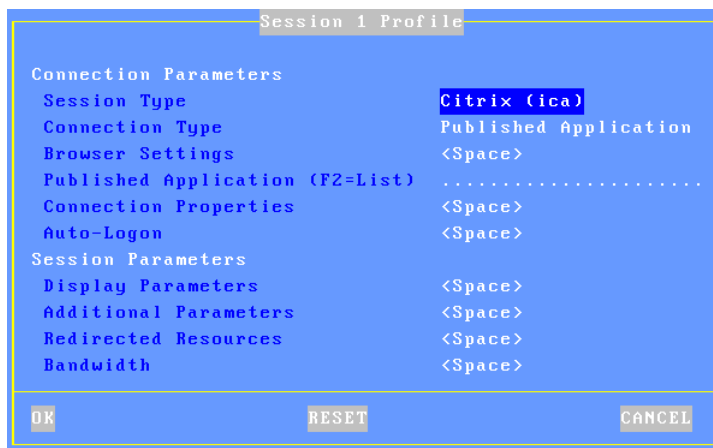

Set the following parameters:

- **Session Type:** select "Citrix (ica)"
- **Connection Type:** select "Server (local list)", "ICA Server" or "Published Application". See Chapter 5.2.2.  
**Note:** for "Citrix Desktop" see Chapter 5.3.
- **ICA Browser Settings** (only for "ICA Server" or "Published Application" target type): pressing <Space> displays a dialog box which allows certain ICA Browsing parameters be changed. For more information, see Chapter 5.2.2.
- **Host or Published Application:** the option for this setting depends on the selected Target Type. See Chapter 5.2.2.
- **Connection Properties:** pressing <Space> displays a dialog box which lets certain connection parameters be changed. See Chapter 5.2.8.
- **Auto Logon:** press <Space> to set the "Automatic Logon" function and/or the "Auto-Run" function. For more information, see Chapter 5.2.5.
- **Display Parameters:** press <Space> to set display settings (resolution and colors). For more information, see Chapter 5.2.3.
- **Additional Parameters:** pressing <Space> displays a dialog box, which lets certain ICA parameters be changed. For more information, see Chapter 5.2.4.
- **Redirected Resources:** press <Space> to set redirected resources (printers, COM ports, etc.). For more information, see Chapter 5.2.6.
- **Bandwidth:** pressing <Space> displays a dialog box which lets certain parameters be changed. For more information, see Chapter 5.2.7.

**Note:** after saving changes power-cycle the AX3000.

## **5.2.2 - Connection Types and ICA Browser Settings**

### ***a) Connection Types***

An ICA session is associated with one of the following connection types:

- **Server (local list):** this is a server previously entered through the menu [Configuration]-[Network]-[Servers]. Select the "**Server**" parameter and press <Space> to display the server list.
- **ICA Server:** this is a server from the Citrix server farm. Select the "**Server**" parameter and manually enter the server name or press <F2> to browse the Citrix server farm.

- **Published Application:** this is a published application from the Citrix server farm. Select the "**Published Application**" parameter and manually enter the application name or press <F2> to browse the Citrix server farm.

**Note:** the destination (ICA server or published application) may be left blank. In this case when the ICA connection is established, the user must select the destination from a list.

### **b) ICA Browser Settings**

For the "ICA Server" and "Published Application" connection types, the ICA Browser Settings are used to dynamically build the server or application list (when <F2> is pressed).

Within the 'Session Profile' box, select 'ICA Browser Settings' and press <Space>. The following box is displayed:

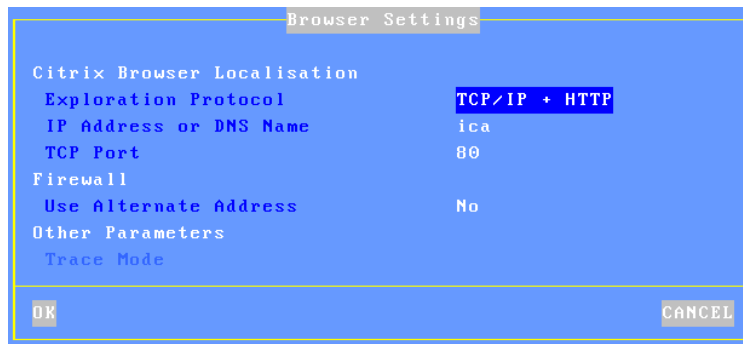

These parameters are:

- **Exploration Protocol:** two available values, and will depend on how the Citrix server is configured:
  - TCP/IP + HTTP: XML-based protocol
  - TCP/IP: UDP-based protocol

For more information please see the Citrix Manual.

- **IP Address or DNS Name:** depending on the exploration protocol, the ICA browsing behavior differs:

- TCP/IP + HTTP: when this parameter is left blank, the ICA request is sent to the DNS name 'ica'. Otherwise it is sent to the entered DNS name or IP address.
- TCP/IP: when this parameter is left blank, the ICA request is broadcasted. When a value is specified, the ICA request is sent to the entered IP address or name (unicast mode). In event of failure the ICA request is sent again in broadcast mode. Entering a server IP address will not force the session to connect to that server, but it will allow the terminal to locate the farm.
- **TCP Port**: with "HTTP + TCP/IP" mode, the default value is 80 and can be modified. With "TCP/IP" mode the value is 1604 and can't be modified.
- **Use Alternate Address**: set it to 'Yes' when a firewall is present.
- **Trace Mode** (not available for HTTP + TCP/IP mode): only use in event of problems during ICA browsing.

### ***c) ICA Browsing Examples***

#### **Example 1:** HTTP + TCP/IP mode

With the Round-Robin DNS mechanism, the all the Citrix servers may be resolved with a single DNS name (ica). In this case, the ICA browsing default settings allow servers or published applications to be listed. Otherwise the IP address (or a DNS name) of one of the server of the Citrix must be specified.

#### **Example 2:** TCP/IP mode, the terminal belongs to the same network as the Citrix farm

The ICA browsing default values should allow the server or application list to be built. (Broadcasted ICA request will be received and processed by ICA servers).

#### **Example 3:** TCP/IP mode, the terminal and the Citrix farm are on separate networks

With the default values the ICA browsing will fail as the broadcast requests will be blocked by routers. The IP address (or a DNS name) of one of the servers of the Citrix farm must be specified.

### 5.2.3 - Display Parameters

Within the 'Session Profile' box, select 'Display Parameters' and press <Space>. The following box is displayed:

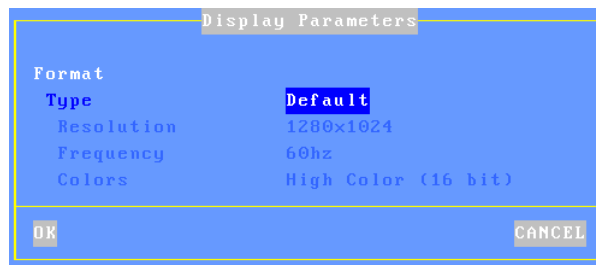

This box allows display settings (resolution, number of colors and frequency) to be set. The availability of these parameters depends of the **Type** value:

- **Default:** these three parameters are issued from general settings (see Chapter 3.2.2). When general settings are modified, these three parameters are automatically updated with new values.
- **Customized:** the three parameters are independent from general settings.

### 5.2.4 - ICA Additional Parameters

Within the 'Session Profile' box, select 'Additional Parameters' and press <Space>. The following box is displayed:

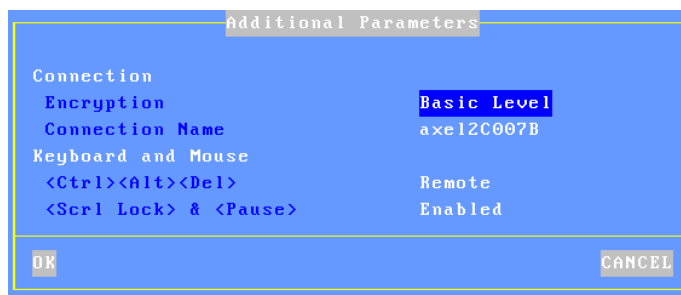

These parameters are:

- **Encryption:** the supported encryption protocols are:

- Basic Level: default encryption protocol of Metaframe.
- RC5: strongest encryption protocol (with different key lengths)
- **Connection Name**: this character string identifies the AX3000 within the Windows Operating System (see CLIENTNAME environment variable). The default value is the terminal name (see Chapter 3.1.1).
- **<Ctrl><Alt><Del>**: the two modes for this keystroke are:
  - Local: the keystroke is handled by the AX3000 and is used for shutdown the terminal (see Chapter 4.5)
  - Remote: the keystroke is handled by the Windows server (for example opening the task manager).
- **<Scroll Lock> & <Pause>**: enable or disable these two keys

### 5.2.5 - Automatic Logon and Auto-Run

Within the 'Session Profile' box, select 'Auto-Logon' and press <Space>. The following box is displayed:

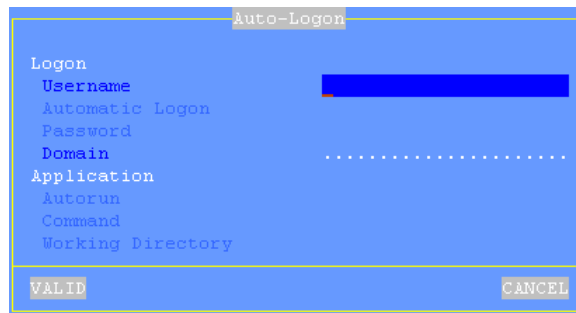

These parameters are:

- **Username**: this is the default value for the username field of the Login screen.
- **Automatic Logon**: set this parameter to 'Yes' to get an automatic logon. For more information about the auto-login, see Chapter 5.5.2.
- **Password** (available only if 'Automatic Logon' is set to 'Yes'): press <Space> to enter the password.
- **Domain**: this is the default value for the Windows domain field of the Login screen.

- **Auto-Run**: by default the Terminal Services connection offers a Windows desktop. To automatically launch a program set this parameter to 'Yes' and complete the following fields.
- **Command** (available only if 'Auto-Run' is set to 'yes'): the program path and file name of the program to be launched.  
Example: %SystemRoot%\system32\cmd.exe
- **Working Directory** (available only if 'Auto-Run' is set to 'yes'): program working directory.  
Example: D:\

### **5.2.6 - Redirected Resources**

The redirected resources mechanism allows one or more local resources to be 'published' to the Windows server. These resources are available only for the terminal's user. They are created on the Windows server when the connection is established and removed when the session is disconnected.

The following local resources are supported:

- **Printers**: before being redirected each printer must be declared at the 'physical connection port' level. See first sub-section a) then c).
- **COM/LPT ports** before being redirected each port must be declared at the physical port level. See first sub-section b) then c) and d).
- **Mass storage devices**: see sub-section c).
- **Smartcard readers**: see sub-section c)
- **Audio**: see sub-section c)

#### ***a) Declaring a Redirected Printer***

At the RDP/ICA connection time a redirected printer will be automatically added to the Windows spooler. It will be removed when the session disconnects.

Before being redirected an RDP/ICA printer must be declared at the 'physical connection port' level. The available ports are: auxiliary ports (parallel, Aux1 and Aux2), USB logical ports and network printers.



Select the dialog box of the 'Connection port' (menu **[Configuration]-[Ports]-[xxx]**). For example, the Aux1 port:

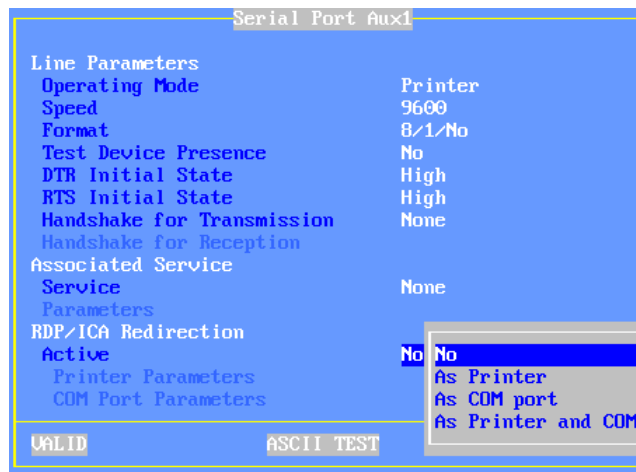

Set the 'Active' parameter to 'As Printer' or 'As Printer and COM'. Then select 'Printer Parameters' and press <Space>. The following box is displayed:

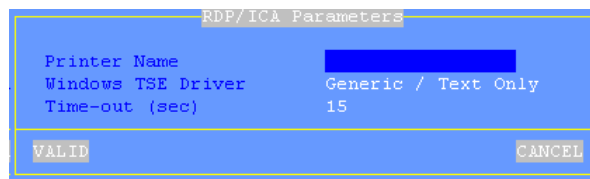

These parameters are:

- **Printer Name:** name of the Windows printer. (User definable)
- **Windows TSE Driver:** printer driver name. It is ESSENTIAL that the value entered here matches the printer driver name exactly as installed on the server. If the match is not exact Windows will not be able to connect the printer to the driver and the printer will not be added to the Windows spooler.
- **Time\_out (sec):** in event of a printer error (no paper, off-line, etc.), this is the delay before the terminal reports the error to Windows.

The printer declaration is completed. For the redirection procedure, consult the

sub-section c).

### **b) Declaring a Redirected COM/LPT Port**

A redirected COM/LPT port will be 'seen' as a local Windows COM/LPT port. Maximum two ports can be redirected.

Before being redirected an RDP/ICA COM Port must be declared at the 'physical port' level. The available ports are: auxiliary ports (parallel, Aux1 and Aux2) and USB logical ports.

Select the dialog box of the 'Connection port' (menu **[Configuration]-[Ports]-[xxx]**). For example, the Aux1 port:

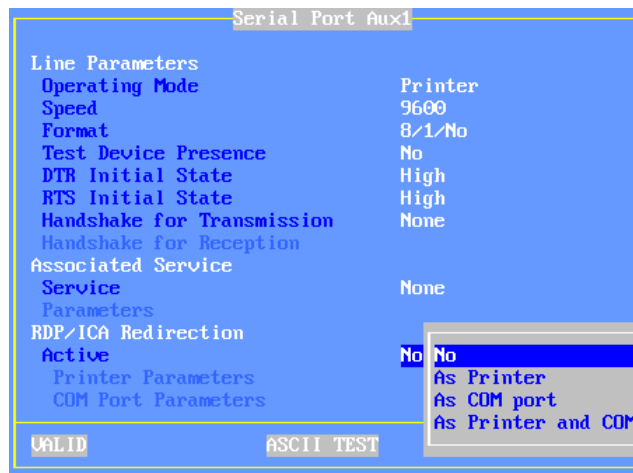

Set the 'Active' parameter to 'As COM port' or 'As Printer and COM'. Then select 'COM Port Parameters' and press <Space>. The following box is displayed:

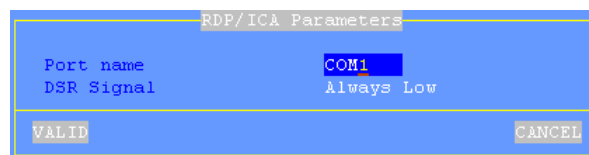

These parameters are:

- **Port Name:** redirect COM port name (from COM1 to COM255).
- **DSR Signal** (only for Aux1 and Aux2): the DSR signal is not supported by the AX3000 native auxiliary ports. This parameter allows the incoming DSR value to be emulated. The possible values are: "Always Low", "Always Up", "Follows CTS" or "Follows CD".

**Note:** for redirecting an LPT port, set the 'Active' parameter to 'As LPT port' or 'As Printer and LPT'. The LPT port settings dialog box only offers to customize the LPT name (LPT1 by default).

The port declaration is completed. For the redirection procedure, consult the next sub-section. Then consult sub-section d) for remapping procedure.

### c) Redirecting Resources within the ICA session

To redirect resources within a session select the session profile box (menu **[Configuration]-[Sessions]-[Session X]**). Within this box, select 'Redirected Resources' and press <Space>. The following box is displayed:

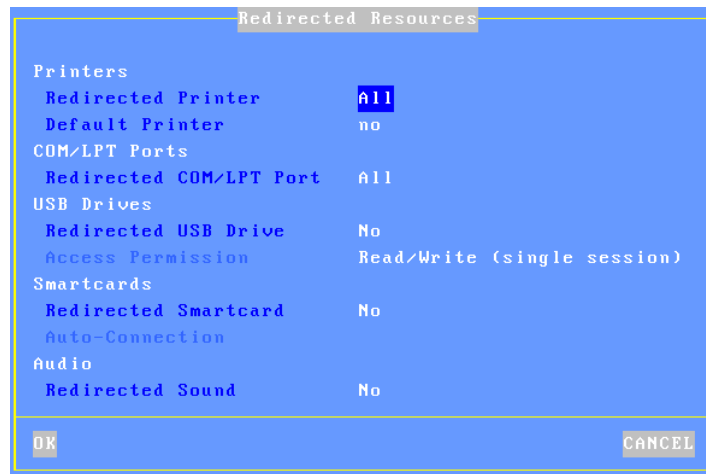

These parameters are:

- **Redirected Printer:** printer(s) are selected through a list. This list is composed by the following items:
  - **All**
  - **None**
  - **Printer Name (port):** these are the RDP/ICA printer name(s). This allows the selection of only one printer to be redirected.
- **Default printer:** set (or not) a printer as the default printer.
- **Redirected COM/LPT Port:** COM port(s) are selected through a list. This list is composed by the following items:
  - **All**
  - **None**
  - **xxx (port):** these are the COM port name(s). This allows the selection of only one COM port to be redirected.
- **Redirected USB Drive:** enable/disable the mass storage device redirection. The 'Access Permission' value is set globally. (See Chapter 3.2.4).
- **Redirected Smartcards:** enable/disable the smartcard redirection.
- **Auto-Connection:** when set to yes, the option allows the ICA session to be automatically established when a smartcard is inserted in the reader.
- **Redirected Sound:** enable/disable the audio redirection.

#### **d) Remapping a COM/LPT port**

Terminal COM ports must be remapped to server COM ports. The remapping commands are "**change client**" or "**net use**". These commands may be issued from a command prompt from the terminal's Citrix session.

Example: the Windows COM4 port is remapped to the terminal COM1 port

**net use com4: \\client\com1:**

or

**change client com4: com1:**

**Note:** this remapped resource is only for the terminal. In this example COM4 is not seen by other users.

☺: How to set-up a user account to automatically launch a "net use" command.

- Create a shareable directory called Netlogon.
- In this directory create a file called "myscript.bat".

- Enter the 'net use' command line as required in this file.
- Edit the user account properties by selecting the 'profile' tab and set the "Logon script" to read the "myscript.bat" file.

For more details see Windows help on Netlogon.

### **5.2.7 - Bandwidth**

Within the 'Session Profile' box, select 'Bandwidth' and press <Space>. The following box is displayed:

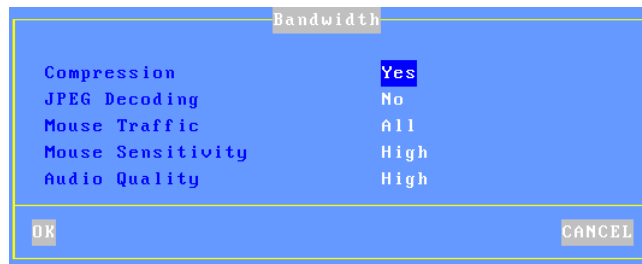

These parameters are:

- **Compression:** this allows Windows to send compressed data. This optimizes bandwidth but in some cases can decrease overall performance.
- **JPEG Decoding:** this allows Windows to send JPEG bitmaps. This optimizes bandwidth but in some cases can decrease overall performance.
- **Mouse Traffic:** the options are:
  - All (default): all mouse events (clicks and position) are sent to the server.
  - Click: only the click events are sent to the server. This reduces the data flow. But the mouse cursor is not updated in real time. This mode can significantly improve bandwidth.
- **Mouse Sensitivity:** This setting varies the sample rate of the mouse. If the sensitivity is increased the mouse movement will be more fluid, but also network activity is increased.
- **Audio Quality:** the bandwidth depends on the audio quality. For remote connections prefer a low quality.

### 5.2.8 - Connection Properties

Within the 'Session Profile' box, select 'Connection Properties' and press <Space>. The following box is displayed:

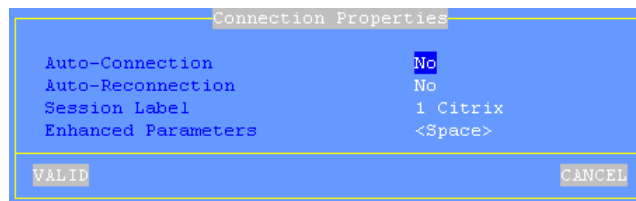

These parameters are:

- **Auto-Connection:** if this parameter is set to 'yes', the connection will be automatically established when the AX3000 is powered. Otherwise, the user can press <Alt><Fx> to establish the connection.
- **Auto-Reconnection:** if this parameter is set to 'yes', a new connection is automatically established after a disconnection. Otherwise, the user can press <Alt><Fx> to establish a new connection.
- **Session Label:** this character string (11 characters max.) is used to identify the session within the session manger or in the status line.
- **Enhanced parameters:** see Appendix A.10.3.

## 5.3 - CITRIX "PUBLISHED APP. DESKTOP" SESSION

(Note this is a unrelated to "connecting to a Citrix desktop as a published application")

The Citrix Published App. Desktop session is comparable in functionality to the Citrix product Nfuse, WEB Interface or Program Neighborhood.

### 5.3.1 - General Configuration of the Published App. Desktop session

The terminal supports a maximum of 6 sessions. When "Published App. Desktop" is used one session is taken by the desktop itself. After the user has been authenticated by the Citrix Server, the Citrix Server sends user specific data through this session to configure the user's individual desktop, i.e.

application icons, screen resolution, number of colors and folder information. This leaves 5 sessions for either published applications or other emulations (telnet, As400, 5250, VNC or RDP)

If the user is authorized with more than 5 applications, icons for all the published applications will be displayed, but only 5 applications can be used concurrently. To access the 'sixth' application one of the initial 5 applications will require closing.

Configuration principles for a Citrix only environment:

- The terminal supports 6 sessions. When "Published App. Desktop" is selected one session is required by the desktop connection itself, the other 5 are available for published applications
- The number of published applications (sessions) can be set to between 1 and 5.
- The published application sessions are 'reserved' without specifying the application
- The Citrix published application sessions are always set up descending from session number 6. For example if three sessions are reserved they will be sessions 6, 5 and 4. Session 1 is used by the desktop and sessions 2 and 3 are available for other emulations, i.e. telnet or As400 (see next chapter).
- Only one "Published App. Desktop" session is possible per terminal.

Configuration principles for a mixed environment:

- The terminal supports 6 sessions. When the "Published App. Desktop" is selected one session is required by the desktop connection itself, the other 5 are available for Citrix published applications or other emulations, i.e. RDP, Telnet, As400....
- Within the "Published App. Desktop" dialog box the number of Citrix published applications is set (1 to 5). If 5 is selected all sessions are reserved for Citrix – if however 3 are selected 2 sessions are available for non-Citrix connections. The total cannot exceed 5.
- The Citrix published application sessions are always set up descending from session number 6, so in the above example sessions 6, 5, 4 will be published applications - and sessions 3 and 2 available for other non-Citrix environments - Only one session "Published App. Desktop" session is possible per terminal

To illustrate this principle below are three examples of session setup

Example 1: terminal dedicated to "Published App. Desktop"

|                      |          |          |          |          |          |
|----------------------|----------|----------|----------|----------|----------|
| Pub. App.<br>Desktop | Reserved | Reserved | Reserved | Reserved | Reserved |
|----------------------|----------|----------|----------|----------|----------|

Example 2: one 5250 session and one "Published App. Desktop" session

|      |                      |          |          |          |          |
|------|----------------------|----------|----------|----------|----------|
| 5250 | Pub. App.<br>Desktop | Reserved | Reserved | Reserved | Reserved |
|------|----------------------|----------|----------|----------|----------|

Example 3: "Published App. Desktop", VNC and ANSI sessions

|                      |     |      |          |          |          |
|----------------------|-----|------|----------|----------|----------|
| Pub. App.<br>Desktop | VNC | ANSI | Reserved | Reserved | Reserved |
|----------------------|-----|------|----------|----------|----------|

To configure the "Published App. Desktop" session, enter (<Ctrl><Alt><Esc>), select the **[Configuration]-[Sessions]-[Session X]** menu (where X is the number of the session. The dialog box below is displayed:

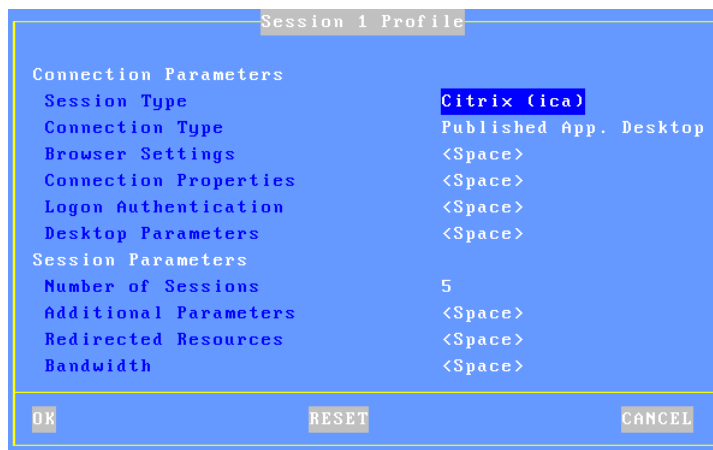

Enter the following values

- **Session Type:** select "Citrix (ica)"
- **Connection Type:** select "Published App. Desktop"



- **ICA Browser Settings:** press the spacebar to select browser settings. (See Chapter 5.2.2.)
- **Connection Properties:** press the spacebar to display the 'Enhanced Parameters' dialog box. See chapter 5.2.8.
- **Logon Authentication:** press spacebar to show a dialog box permitting the user's name, password and domain to be entered. This removes the need to enter these details for every logon.
- **Desktop Parameters:** press spacebar to show a tuning box. See Chapter 5.3.2.
- **Number of Sessions:** this sets the number of sessions reserved for published applications on the "Published App. Desktop" session.

**The following parameters are used dynamically by ICA to set up the published applications.**

- **Additional Parameters:** press spacebar to show dialog box to set further settings. See chapter 5.2.4.
- **Redirected Resources:** press <Space> to set redirected resources (printers, COM ports, etc.). For more information, see Chapter 5.2.6.
- **Bandwidth:** press spacebar to show dialog box for bandwidth management settings. See chapter 5.2.7.

**Notes:**

- After changing setup parameters it is necessary to reboot the terminal to ensure the new values are used.
- Once "Published App. Desktop" is setup the reserved sessions are inaccessible from the setup menus.
- The setting up of a "Published App. Desktop" activates the status line allowing sessions to be changed with the mouse.

### 5.3.2 - Desktop Parameters

Within the 'Session Profile' box, select 'Desktop Parameters' and press <Space>. The following box is displayed:

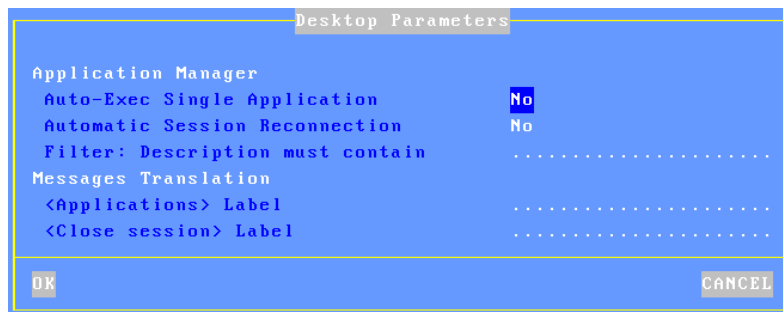

These parameters are:

- **Auto-Exec Single Application:** in event of only one application is published, this parameters allows to run it automatically.
- **Automatic Session Reconnection:** this parameters, also known as "smooth roaming", allows a user to retrieve his former sessions when reconnection from another workstation. The reconnected session type can be "**disconnected**" or "**disconnected and actives**".
- **Filter: Description must contain:** this allows displaying only published applications with a description field including the entered character string.
- **<Applications> label:** customized label for the "Applications" message located on the upper/left corner (see screen-shot at the next chapter).
- **<Close session> label:** customized label for the "Close session" message located on the lower/left corner (see screen-shot at the next chapter).

### **5.3.3 - Using the "Published App. Desktop"**

#### **a) Authentication**

On establishing the "Published App. Desktop", authentication is requested. (Username, password and domain.) A local dialog box requests this information as below:



These authentication parameters are sent to the Citrix servers which permit or deny the user access. The user name (and password) can be entered in the terminal's setup to remove the need to re-enter on every login. See Logon Authentication above

On successful authorization the application list and characteristics (name, icons...) is sent to the terminal. The desktop is created locally using this information.

**b) Using the Desktop**

After authentication the user is given a standard graphical interface for launching applications:

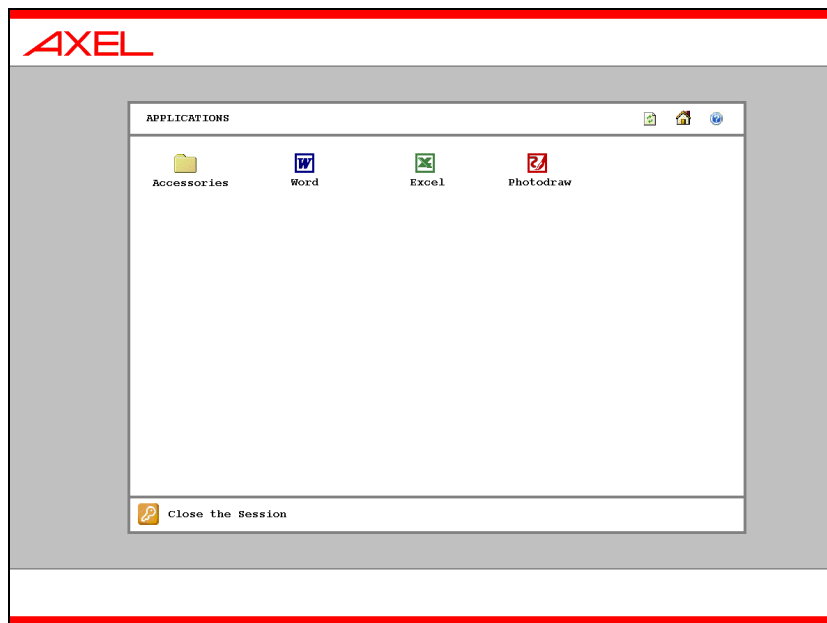
**Notes:**

- The screen is slightly different for different screen resolutions
  - 1280x1024 – the screen displayed is as above
  - 1024x768 – the upper banner is not displayed
  - 800x600 – neither upper nor lower banner are displayed
- The 'Refresh' icon (top right corner) refreshes the desktop
- The 'Folder' icon is a standard Citrix offering and can be used to contain and organize application icons. Sub-folders are supported
- The 'House' icon (top right) returns the user directly to the root folder.

When the user clicks on an application icon the terminal uses the first free reserved session to launch an ICA connection. If all the reserved sessions are already in use the terminal will beep.

**General ICA Session Information:**

- A new ICA connection becomes the current session.
- The Citrix server hosting this session is localized with the browser parameters.
- The ICA session uses the general operational parameters specified in the set-up (encoding, bandwidth...).
- The screen resolution and number of colors for all published applications is set by the Citrix server for that application. If the resolution is not available or is incorrect the desktop resolution is used.

***c) Closing the Desktop***

The 'Key' icon is used to shutdown the desktop. All applications must first be closed before the Desktop can be shutdown. If any applications are still open when shutdown is attempted the terminal will emit a beep and not shutdown.

## 5.4 - VIRTUAL DESKTOP SESSION

### 5.4.1 - Setting-Up an Virtual Desktop Session

To set a Virtual Desktop session, enter the AX3000 Set-Up and select the **[Configuration]-[Sessions]-[Session X]** menu (where X is the session number to be configured). The following box is displayed:

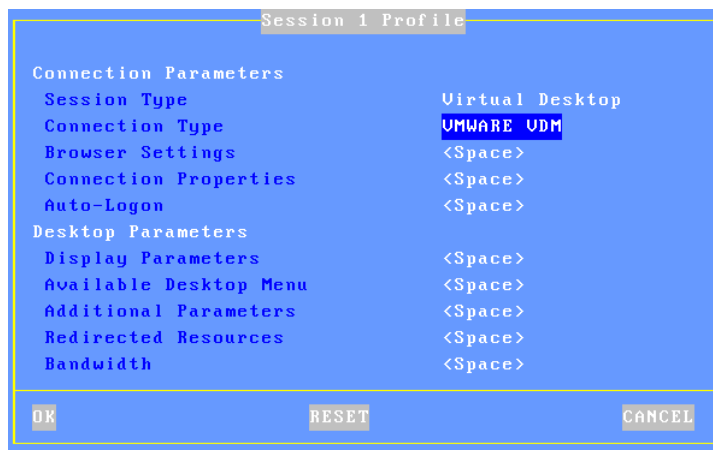

Set the following parameters:

- **Session Type:** select "Virtual Desktop"
- **Connection Type:** press <Space> to select the "VMWARE VDM" or "Citrix Xen Desktop". See Chapter 5.4.2
- **Browser Settings:** press the spacebar to select browser settings (see chapter 5.4.2)
- **Connection Properties:** press the spacebar to display the 'Enhanced Parameters' dialog box. See chapter 5.2.8.
- **Auto Logon:** press <Space> to show a dialog box permitting the user's name, password and domain to be entered. This removes the need to enter these details for every logon. See Chapter 5.4.4
- **Display Parameters:** press <Space> to set display settings (resolution and colors). For more information, see Chapter 5.2.3.
- **Available Desktop Menu:** press <Space> to customize the dialog box where virtual desktop list will be displayed. For more information, see Chapter 5.4.3.

- **Additional Parameters:** pressing <Space> displays a dialog box, which lets certain parameters be changed (connection name, time zone...). If the "Connection Type" is "VMWARE VDM", see Chapter 5.1.3. otherwise see Chapter 5.2.4.
- **Redirected Resources:** press <Space> to set redirected resources (printers, COM ports, etc.). For more information, see Chapter 5.2.6.
- **Bandwidth:** pressing <Space> displays a dialog box, which lets certain parameters be changed. If the "Connection Type" is "VMWARE VDM", see Chapter 5.1.6. Else see Chapter 5.2.7.

**Note:** after saving changes power-cycle the AX3000.

#### **5.4.2 - Connection Type and Browser Settings**

##### ***a) Connection Types***

For a virtual desktop session the connection type is the "connection broker". The following are supported:

- **VMWARE VDM**
- **Citrix Xen Desktop**

##### ***b) Browser Settings***

For handling a virtual desktop session (authentication, list and connection) the terminal must be first connected to a "Connection Broker".

To set or to consult the connection broker setting within the 'Session Profile' box, select 'Browser Settings' and press <Space>. The following box is displayed:

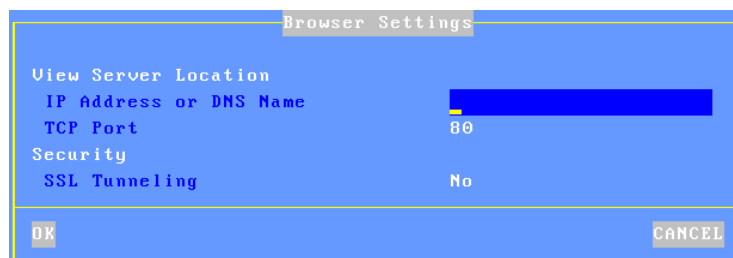

|                        |                      |
|------------------------|----------------------|
| View Server Location   |                      |
| IP Address or DNS Name | <input type="text"/> |
| TCP Port               | 80                   |
| Security               |                      |
| SSL Tunneling          | No                   |
| OK                     | CANCEL               |

Enter details for locating the connection broker:

- IP address (or the DNS name)
- TCP port (generally 80 for HTTP and 443 for HTTPS).
- If the connection type is HTTPS, enable "SSL Tunneling"

### **5.4.3 - Available Desktop Menu**

After being authenticated to the connection broker, the virtual desktop list will be displayed. This dialog box allows this list to be customized:

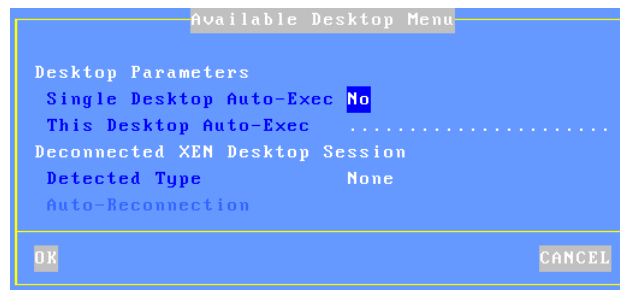

In event of only one desktop is listed, the parameter "**Single Desktop Auto-Exec**" allows this desktop to be automatically launched.

The parameter "**This Desktop Auto-Exec**" allows a pre-defined desktop to be automatically launched (if available in the desktop list).

For "Citrix Xen Desktop" configuration, disconnected session can be listed and eventually automatically reconnected.



#### **5.4.4 - Automatic Logon**

Within the 'Session Profile' box, select 'Auto-Logon' and press <Space>. The following box is displayed:

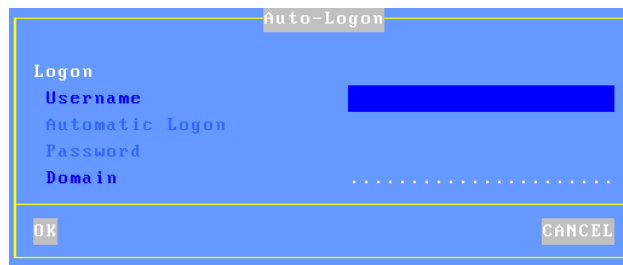

These parameters are:

- **Username:** this is the default value for the username field of the Login screen.
- **Automatic Logon:** set this parameter to 'Yes' to get an automatic logon.
- **Password** (available only if 'Automatic Logon' is set to 'Yes'): press <Space> to enter the password.
- **Domain:** this is the default value for the Windows domain field of the Login screen.
- **Note:** for a VMWARE VDM configuration, this domain field is not available.

### **5.4.5 - Using the "Virtual Desktop" Session**

#### ***a) Authentication***

On establishing the "Virtual Desktop" session, authentication is requested. (Username, password and domain). A local dialog box requests this information as below:

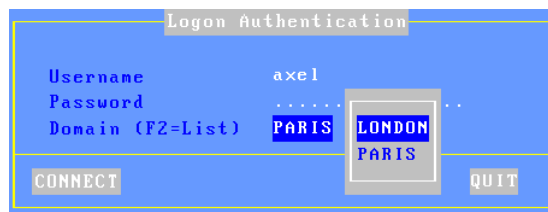

**Note:** with a VMWARE VDM connection broker the domain name is selected though a list. (With Citrix Xen Desktop, the domain name is manually entered)

#### ***b) Virtual Desktop List***

After the authentication is passed, the virtual desktop list is displayed:

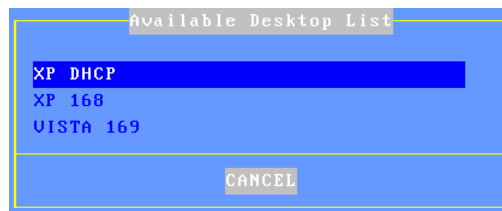

After the virtual desktop is selected by the user, the terminal requests connection information to the connection broker.

After few seconds, the target virtual machine desktop should be displayed.

### **5.4.6 - Configuring the VDM Connection Broker**

To use an Axel terminal the VDM connection broker must be configured with "Direct connection to desktop" enabled (after the authentication stage, the

broker is no longer used, the RDP connection is directly established to the virtual machine). To check (or change) this parameter, enter the 'View server' configuration.

With VIEW 4, enable the 'Direct connection to desktop' option:

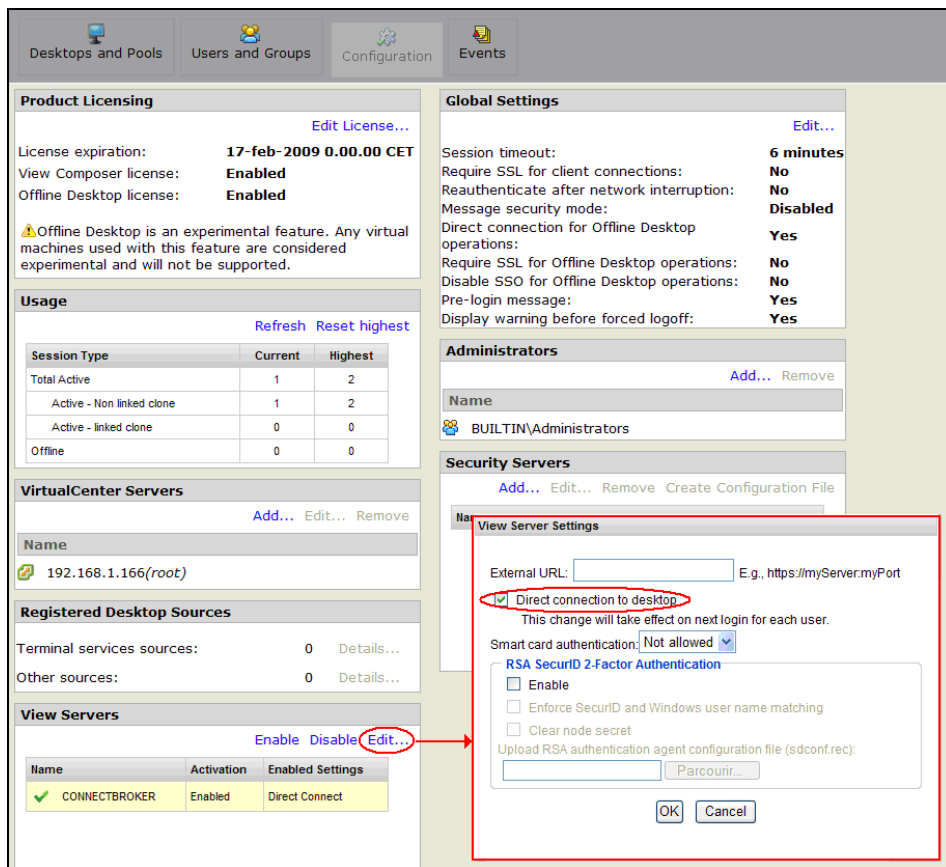

With VIEW 4, disable the 'Use secure tunnel connection to desktop' option:

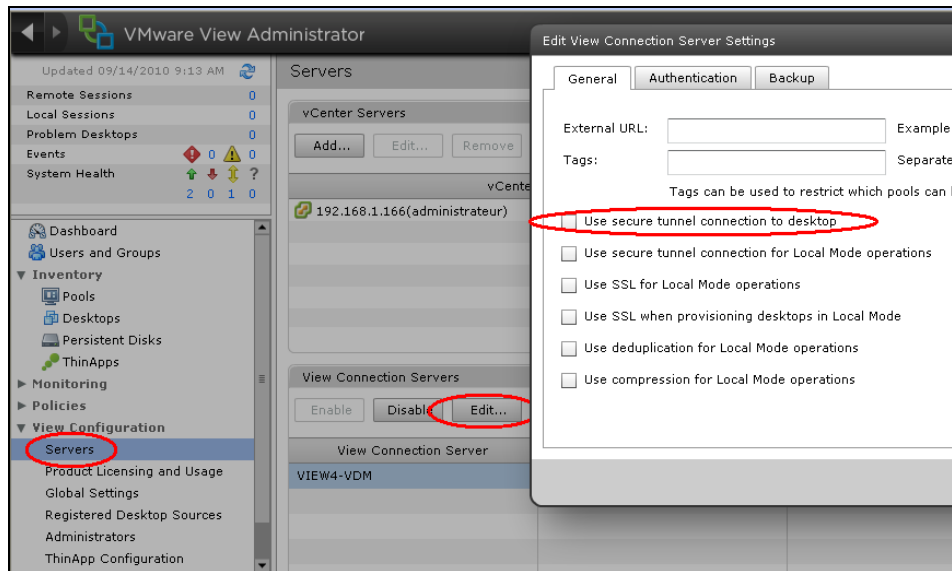

## 5.5 - CONFIGURING THE WINDOWS SERVER (ICA/RDP)

**Warning:** it is assumed that the Terminal Server is fully licensed, and terminal services are fully installed and enabled. Please consult the Microsoft documentation for more information.

The RDP or ICA server configuration is performed through the "Terminal Services Configuration" utility (in the 'Administrative Tools' folder).

When this utility is run the dialog box below is displayed:

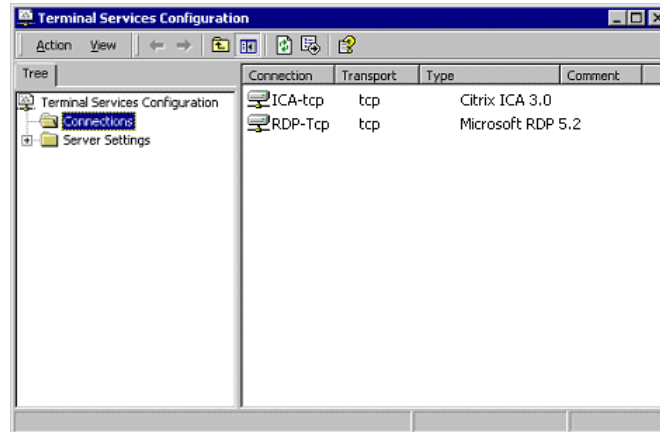

Select 'Connections' in the left panel. On the right panel, double-click the line 'RDP-Tcp' or ('ICA-Tcp') to configure the RDP server (or ICA server). Another dialog box is displayed. It allows setting:

- The encryption level,
- The automatic logon,
- The idle session limit.

#### **5.5.1 - Encryption Level**

The data flow between the RDP or ICA server and the client is generally encrypted. The encryption mechanism depends on the protocol.

##### ***a) RDP Protocol***

Three encryption levels are available:

- **Low**: only the data flow from the client to the server is encrypted (i.e. user names and passwords).
- **Client compatible** (or **medium**): data flowing in both directions (from the client to the server and from the server to the client) is encrypted.
- **High**: data flowing in both directions is encrypted to a higher level.

The terminal encryption level must match that of the server.

**Note:** despite its name low encryption level is a satisfactory security level in most cases. Within Server\Terminal communication, only data sent by the terminal is critical (password, confidential code, etc). The unencrypted data sent from the server is the physical screen display, i.e. colored pixels and not text.

To modify the encryption level, within the 'RDP-Tcp Properties' box, click on the 'General' tab. The following information is displayed:

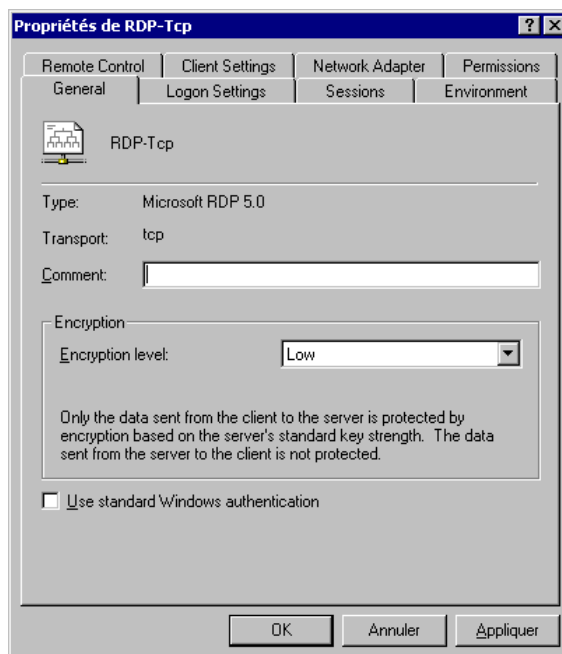

Set the 'Encryption level' parameter to 'Low', 'Medium' or 'High'.

#### ***b) ICA Protocol***

The available encryption levels are:

- **None**
- **Basic level.**
- **RC5.**

To modify the encryption level, within the 'ICA-Tcp Properties' box, click on the

'General' tab. The same dialog box than RDP protocol is displayed.

Set the 'Encryption level' parameter to 'None' or 'Basic'.

### **5.5.2 - Automatic Logon**

Information required for logon (username, domain name and password) can be provided by the terminal. This saves manually entering this information at every logon.

This feature must be enabled at the Windows server level (by default an automatic password is not accepted by the server).

To allow automatic logon, within the 'RDP-Tcp (or ICA-Tcp) Properties' box, click on the 'Logon Settings' tab. The following information is displayed:

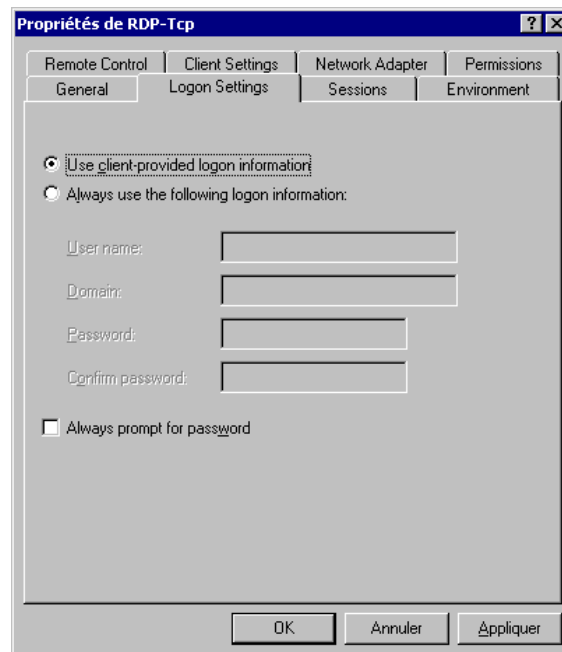

Disable the 'Always prompt for password' check box.

### 5.5.3 - Idle Session Limit

When the AX3000 is powered off without logging out, the current TCP/IP connections remain active on the server side (see Chapter 5.5.3).

To avoid these 'phantom' sessions, an automatic clean-up mechanism is offered. This shuts down the idle sessions after a certain time.

The idle session disconnection can be set either at the user settings level (see the User Properties dialog box) or at a global level. For this second method, within the 'RDP-Tcp (or ICA-Tcp) Properties' box, click on the 'Sessions' tab. The following information is displayed:

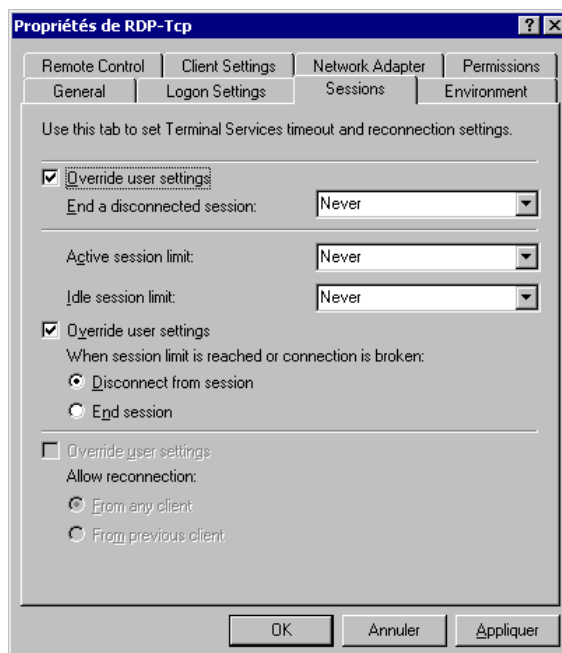

Enable the 'Override user settings' check box and set the required delay for the 'Idle session limit' parameter.

**Warning:** an idle session can be either a 'phantom' session or real used session on which no action has been perform for a certain time (for example over lunch



time). Take care to set an appropriate delay for the terminal's use.

### 5.5.4 - Desktop Background with Windows 2003

By default, with a Windows 2003 server, it is impossible to select a desktop background for an RDP terminal.

To allow a desktop background, run the "Group Policy Object Editor" (GPEDIT.MSC):

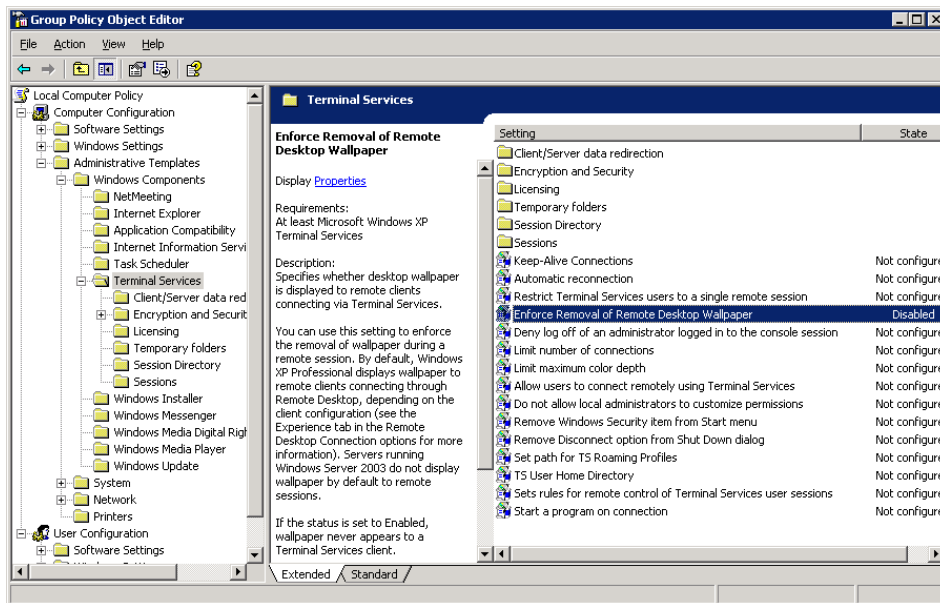

Expand the tree to [Computer Configuration]-[Administrative Templates]-[Windows Components]-[Terminal Services]. Set the parameter "Enforce Removal of Remote Desktop Wallpaper" to "Disabled".

**Note:** the use of a desktop background must also be allowed within the terminal set-up. See Chapter 5.1.6.

### 5.5.5 - Allowing Blank Passwords with Windows 2003

By default, with a Windows 2003 server, it's impossible to set a blank password for a remote user.

To allow blank passwords run the "Local Security Policy" utility (in [Start]-[Program]-[Administrative Tools]):

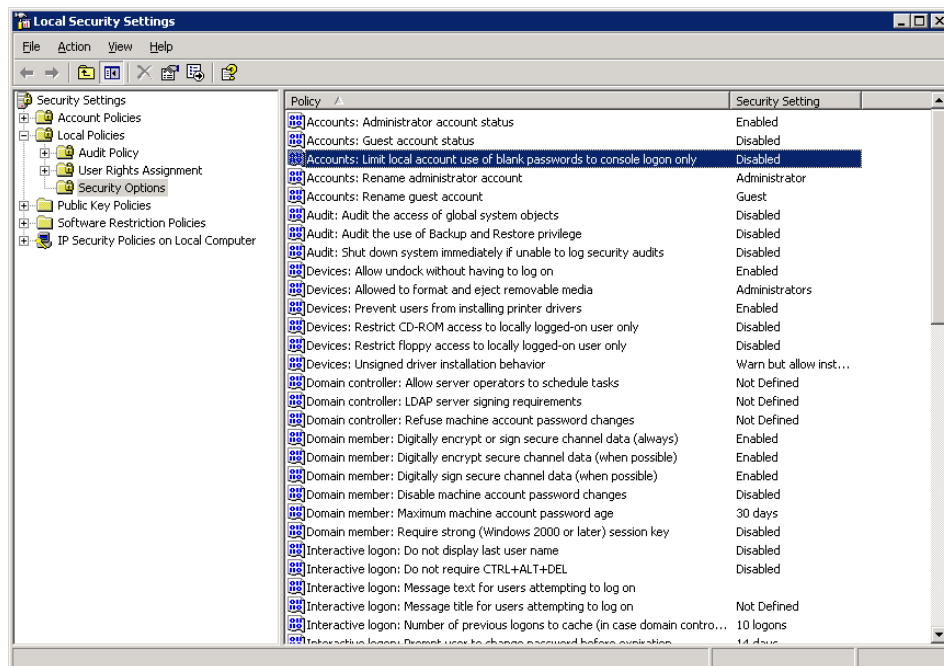

Expand the tree to [Security Setting]-[Local Policies]-[Security Options]. Set the parameters "Accounts: Limit local accounts use of blank password to console logon only" to "Disabled".

### 5.5.6 - Time Zone Redirection

A 2003 server allows individual terminals to negotiate and display a different time zone to the server. This is useful where the server and terminals are in different countries.

For terminal configuration, please refer to Chapter 3.2.4.

**a) With a Windows TSE Server**

By default, with a Windows 2003 server, the time zone redirection is disabled. To enable it run the "Group Policy Object Editor" (GPOEDIT.MSC). See screen shot in sub section d.

Expand the tree to [Computer Configuration]-[Administrative Templates]-[Windows Components]-[Terminal Services]-[Data Client/Server Redirection]. Set the parameter "Enabling Time Zone Redirection" to "Enabled".

**b) With a Citrix Server**

The time zone redirection can be enabled/disabled either by the Farm's properties or by creating a 'Strategy'. For more information, please read the Citrix administrator's Guide.

**5.5.7 - Closing Phantom Sessions**

When the AX3000 is turned off without logging out, the current TCP/IP connection remains active on the server side (see Chapter 5.6.3).

To close such sessions, use the "Terminal Services Manager" utility (on the 'Administrative Tools' folder).

When this utility is run, a dialog box as shown below is displayed:

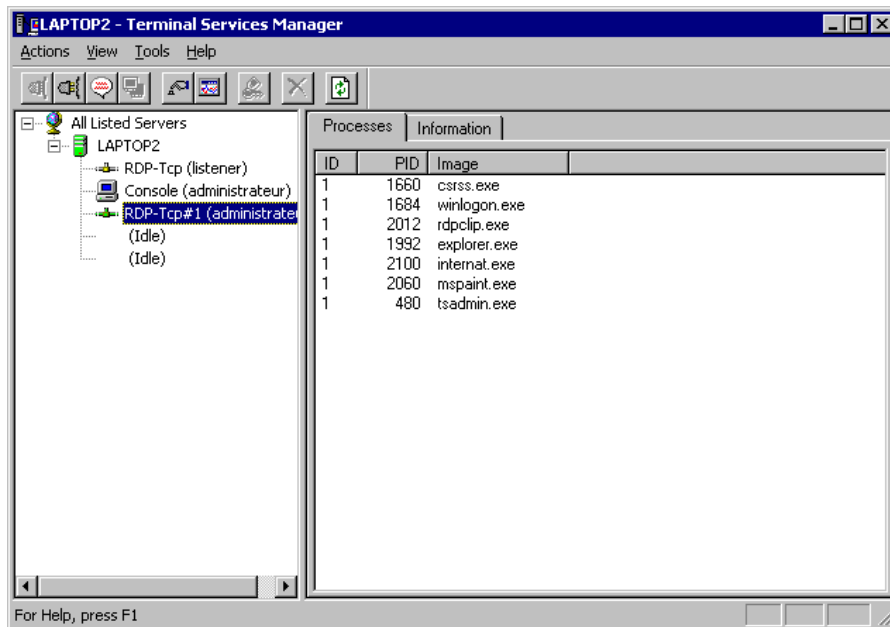

On the left panel, select the session to be killed, then right-click. Within the displayed menu, select 'Disconnect' command. After confirmation, the selected session will be closed and removed from the session list.

## 5.6 - USING THE AX3000

### 5.6.1 - Opening a Windows Session

On successful connection, the AX3000 displays the graphical login screen or the desktop if the automatic-logon function is set.

### 5.6.2 - Information about a Windows Session

Use <Ctrl><Alt><Shift><I> to get information about the active Windows

session.

When the session is established, the value of certain parameters can be re-negotiated by the server (for example the number of colors). This information box gives the values actually used:

|                      |                           |
|----------------------|---------------------------|
| Server IP Address    | a.b.c.d                   |
| Server Version       | RDP 5                     |
| License              | License Token Transmitted |
| Connection Name      | axel0B1111                |
| Encryption           | Medium level (128 bits)   |
| Number of colors     | 65536 (16bpp)             |
| Resolution           | 1280x1024 60 Hz           |
| Compression Required | Screen                    |
| Screen               | yes, 64 Ko                |
| Printer and Aux.     | no                        |
| Redirected Printer   | not required              |
| Redirected COM Port  | not required              |
| Redirected USB drive | not required              |
| Redirected smartcard | not required              |
| Redirected audio     | negotiate (PCM)           |
| Received format      | PCM 16bits, stereo, 22KHz |

Press any key

### **5.6.3 - Closing a Windows Session**

When a session is closed, the AX3000 either reconnects to the same session, displays the 'idle screen', or reverts to the first active session.

Three cases of disconnection can be distinguished.

#### ***a) Log Off from the Desktop***

From the '**Start**' menu, select '**Shut Down**'. Within the list, select '**Log off xxx**'. Windows ends active applications, closes the desktop and disconnects the session (at the TCP/IP level).

#### ***b) Disconnect from the Desktop***

From the '**Start**' menu, select '**Shut Down**'. Within the list, select '**Disconnect**'. The Windows Operating System disconnects this session (at the TCP/IP level).

But in this case, the current environment (desktop and applications) is maintained. The user will be able to retrieve this environment the next time the connection is opened.

### ***c) Disconnect by the AX3000***

The <Ctrl><Alt><Shift><D> keystroke (locally processed by the AX3000) allows the current session to be disconnected and works regardless the protocol or emulation.

As above, the session is disconnected (at the TCP/IP level) but the current environment (desktop and running applications) is not closed. The user will be able to retrieve this environment the next time the connection is opened.

### **5.6.4 Turning-Off the AX3000**

If the AX3000 is powered off without logging out problems may be encountered.

The Windows Operating System cannot detect a TCP/IP device being turned-off, so the current RDP or ICA connections remain active at the operating system level.

If the operating system doesn't provide an automatic procedure to allow sessions to time out, these 'phantom' connections will stay alive until the operating system is rebooted.

To avoid this scenario there are two possible methods:

- Using a time-out to close idle session - See Chapter 5.4.3,
- Manually disconnecting the phantom session(s) - See Chapter 5.4.7.

### **5.6.5 - In Event of Connection Problems**

Most problems occurring on initial connection time are related to licensing problems. The possible errors are:

1. No more TSE Cal is available: new CAL must be bought.
2. The Axel terminal had been already connected to another TSE server. In this case, the license token stored by the Axel terminal is not compliant with this server. To reset the Axel "License Store", enter the AX3000 Set-Up, select

**[Configuration]-[Advanced]-[License Store]**. The displayed dialog box allows you to delete the current license token(s).

3. The Windows server doesn't convert a temporary license to a 'standard' license. The server must be updated:
  - For Windows 2003, install Service Pack 1.
  - For Windows 2000, please consult <http://support.microsoft.com/default.aspx?scid=kb:en-us:827355>

## 5.7 - MANAGING PRINTERS

Auxiliary ports (2 serial and 1 parallel), USB logical ports and network printers are provided by the AX3000. These ports are independently controlled so multiple printers can be attached to the AX3000.

The AX3000 offers an embedded LPD protocol. This protocol is available in most operating systems and allows one or more printers connected to the AX3000 to be accessed as network printers. (I.e. these printers are controlled through the spooler and are available for all authorized users).

**Note:** Windows 2000 and 2003 support RDP printer redirection. The same printer can be handled with both LPD and RDP redirection protocols.

The main characteristics of these protocols are:

### **LPD Protocol: (Server level printer)**

- The printer must be added to the Windows spooler by the administrator.
- The printer name is static.
- The printer is available when the terminal is powered-on and can be accessed by any user.
- The printer dataflow is not compressed.
- The display and printer data flows are multiplexed by TCP/IP.
- There is no requirement for any terminal sessions to be connected
- Printer data compression is not possible

**RDP/ICA Protocol: (Client level printer)**

- The printer is automatically created when the session is established.
- The printer name is static: "terminal name / printer name / session X" (the session number can varied).
- The printer is only available when the session is established. This printer is the user default printer. This printer is not "seen" by other users.
- The printer dataflow can be compressed.
- The display and printer data flows are multiplexed by TSE.

The following applies only with LPD printer configuration. For an RDP printer see Chapter 5.1.5 and for an ICA see Chapter 5.2.6.

**5.7.1 - Setting-Up the AX3000**

To set the LPD service on the terminal port, select the **[Configuration]-[Ports aux.]-[xxx]-[yyy]** dialog and enter the following parameters:

- **Associated Service:** select lpd.
- **Net Service Parameters:** press <Space> to access the following dialog box:

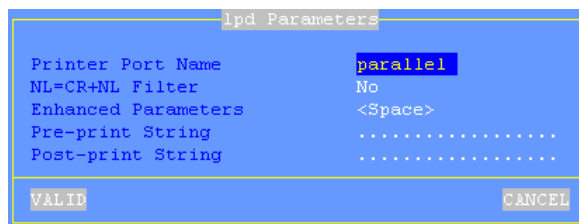

- **Printer Port Name:** this is the port identifier. Sometimes the same name is used for the printer at the operating system level.
- **NL=CR+NL Filter:** set to "no",
- **Enhanced parameters:** see Appendix A.10.3.
- **Pre-print String:** normally not used.
- **Post-print String:** normally not used.

**Note 1:** If "Choose Portrait/Landscape" is enabled (see Appendix A.10.2), the parameter "**Pre-print String**" is replaced by the two parameters "**Portrait Pre-print String**" and "**Landscape Pre-print String**".

**Note 2:** if the auxiliary port used for printing is a serial port, set the 'Printer' operating mode.



### **5.7.2 - Setting-Up the Windows Server**

To add a printer, select the '**Add printer**' icon (in the 'Start'[]'Settings'[]'Printers' menu).

Within the displayed dialog box, select '**Local printer**' (Disable the Plug-And-Play detection). Click on 'Next'.

Within the next dialog box, select '**Create a new port**' and select '**LPR Port**'. Click on 'Next'.

**Note:** if 'LPR Port' is not available, you need to install '**Print Services for Unix**' from the Windows CD-Rom.

Finally within the next dialog box, enter the two parameters requested:

- Name or address of the server providing LPD: AX3000 IP address
- Name of printer or print queue of that server: this is the '**Printer Port Name**' AX3000 Set-Up parameter (see Chapter 2.2).

When this printer is added, all print jobs sent to this printer are automatically redirected to the AX3000.

## **5.8 - PUBLISHING APPLICATIONS**

A Windows TSE application publishing utility (AxMenu or Axel Menu) is available from (<http://www.axel.com>).

TSE gives the user access to a standard Windows desktop, but this may provide too much freedom for users to access the Windows operating system or applications they are not meant to access. They may also be able to change setup and configuration parameters.

AxMenu allows users access only to applications the administrator has authorized and is often a much more user friendly method to control access as compared to restricting Window's user profiles

The administrator creates a profile for each user which sets the appearance of

the screen (Menu, Tool-bar or Desktop) and applications available.

**Example of 'Menu':** the menu is displayed in the centre of the screen.

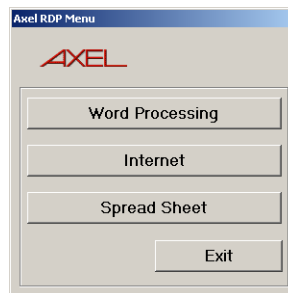

**Example of 'Toolbar':** the tool-bar displayed along the top of the screen



**Example of 'Desktop':** a task bar is displayed at the bottom of the screen



For more information about the AxMenu utility, read the manual "*Axel Menu - Publishing Applications and Securing the Desktop for Windows TSE*".

## 5.9 - REMOTE ADMINISTRATION

### 5.9.1 - Remote Control

This functionality allows an administrator to remotely take control of a terminal

connected to a Windows or Citrix server. The administrator can passively watch the users screen or actively take control with his own keyboard and mouse for various support or administration purposes.

The following diagram clarifies the concept of remote control with RDP protocol (the same principles apply for ICA connections):

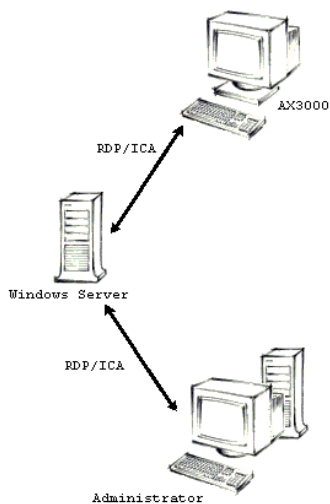

The procedure to take control of a remote terminal is as follows:

- Open an administrator RDP connection to the Windows server
- Launch 'Terminal Services Manager' from 'Administrative Tools'.
- All connected terminals are listed – select target for remote control.
- Activate "remote control" by right mouse click.

After the terminal's user has given authorization the remote control connection is established. The administrator "sees" the same screen as the terminal user.

### **5.9.2 - The Axel Remote Management Software (AxRM)**

A Windows administration utility (AxRM or Axel Remote Management) is available at no charge from the Axel Web site (<http://www.axel.com>).

For more information, please refer to Chapter 10.1.



**- 6 -**  
**INSTALLING UNDER OS/400**

*This chapter covers AX3000 installation under OS/400.*

This chapter describes the operation of the AX3000 in an OS/400 environment. For more general information about the AX3000 (network and session settings, etc) please refer to the previous chapters.

The AX3000 is able to handle both 5250 screen sessions (tn5250 emulation) and printers (protocols PRT5250 and LPD).

## **6.1 - 5250 SCREEN SESSION**

The IBM 5250 emulation type developed by Axel is IBM-3477-FC.

This emulation provides all the features of an IBM 5250 terminal. Especially:

- Enhanced 5250 telnet protocol (TN5250E): compliant with the RFCs 1205 and 2877 (terminal name negotiation, terminal type negotiation, etc.),
- Color support,
- Screen sizes: 80x24 and 132x27,
- 5250 status line.

### **6.1.1 - Keyboard Type**

#### ***a) Setting-Up the Keyboard Type***

The AX3000 supports both a 5250 (122 keys) and a PC/AT keyboard (102/105 keys). The keyboard type is not auto-detected.

To set the keyboard type, enter the AX3000 Set-Up and select the **[Configuration]-[Advanced]-[Tuning]** menu. Set the "Keyboard Type" to "PC"

or "AS400 (F24)" in the displayed box

Press **<Alt><Rest><SetUp>** to enter the AX3000 Set-Up with an AS400 keyboard.

***b) In event of problems***

If the AX3000 setting is not consistent (a PC keyboard is attached but a 5250 keyboard is declared, or vice versa), the keyboard won't work.

A specific keystroke allows the keyboard type to be dynamically toggled. This keystroke is **<Ctrl><Alt><K>** with a PC keyboard, and **<Rest><Alt><K>** with a 5250 keyboard.

**6.1.2 - Setting a Session**

To set a profile session, enter the AX3000 Set-Up and select the **[Configuration]-[Sessions]-[Session X]** menu (where X is the session number to be configured). The following box is displayed:

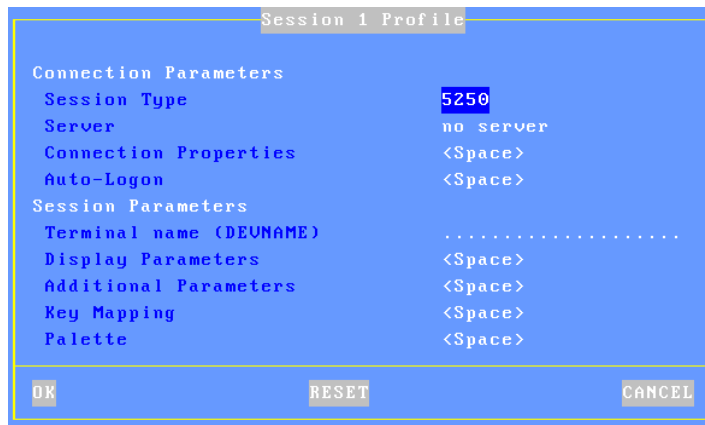

These parameters are:

- **Session Type:** select "5250"
- **Server:** press <Space> to select the server from a list
- **Connection Properties:** pressing <Space> displays a dialog box which lets certain connection parameters be changed. See Chapter 6.1.6.

- **Auto-Logon:** press <Space> to set the Auto-Signon function (see Chapter 6.1.5).
- **Terminal Name (DEVNAME):** if this name is left blank, the OS/400 will associate a dynamic name to this terminal (i.e.: QPADEV001).
- **Display Parameters:** press <Space> to set display settings. For more information, see the next chapter.
- **Additional Parameters:** pressing <Space> displays a dialog box which lets certain emulation parameters be changed. See Chapter 6.1.5.
- **Key Mapping:** pressing <Space> displays a dialog box which lets any keys be remapped. See Chapter 6.1.5.
- **Palette:** pressing <Space> displays a dialog box which lets emulation colors be remapped. See Chapter 6.1.5

Save and exit the set-up. The AX3000 is ready for use.

### **6.1.3 - Display Parameters**

Within the 'Session Profile' box, select 'Display Parameters' and press <Space>. The following box is displayed:

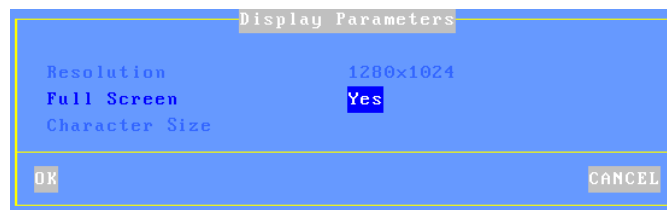

These parameters are:

- **Resolution:** For information only. This is the resolution selected in the [Configuration]-[Terminal]-[Screen] menu.
- **Full Screen:** two possible values:
  - 'Yes': the session is displayed on the entire screen and the character size is automatically adapted to the resolution and the number of lines/columns.
  - 'No': the session is displayed in a 'Window' mode and the character size can be customized.
- **Character Size** (Only when 'Full Screen' is disabled): Two possible values: 'standard' (8x16) or 'double' (16x32).



**Note:** for more information, please refer to Appendix A.10.5.

#### **6.1.4 - Customizing 5250 Emulation**

Various 5250 emulation parameters can be modified but generally the default values are the most suitable.

To customize the 5250 emulation, enter the AX3000 Set-Up and select the session profile (**[Configuration]-[Sessions]-[Session X]** menu). Three groups of parameters control 5250 emulation settings:

- General Parameters: 5250 emulation behavior,
- User-defined Sequences: mapping 5250 functions to any PC keyboard keys.
- Palette: remapping emulation colors.

##### **a) 5250 Emulation General Parameters**

Within the 'Session Profile' box, select 'General Parameters' and press <Space>. The following box is displayed:



These parameters are:

- **EBCDIC Character Set:** possible values are:
  - National (characters are keyboard nationality dependent),
  - Multinational.
  - A specific keyboard nationality (American, French...).
- **Cursor Shape:** Line, Half-Block or Block.  
**Note:** to change the cursor shape from a 5250 session press <Alt><F11> (or <Alt Gr><F11> with a PC keyboard).
- **Cursor Style:** Blinking or Steady.
- **CAPS Key Mode:** set the CAPS LOCK to behave in either of three ways:
  - Caps Lock: each alphabetical key sends the corresponding upper case letter. To unlock this mode press the <CAPS> key.
  - Shift Lock: each key send the same character sent by pressing <Shift><This key>. To unlock this mode press a <Shift> key.
  - Uppercase: each key send the upper character if it is present. Otherwise, this is the lower character (upper-case letter if possible) which is sent. <Shift> key acts in the standard way (whatever the CAPS key). To unlock this mode press the <CAPS> key.
  - Caps Lock +: same as 'Shift Lock'. But in addition ALL the keys supported (including <Esc>, function keys...).
- **Euro Coding:** Euro symbol support. The three possible values are:
  - No: no specific processing is done
  - Standard: the Euro symbol replaces the international currency symbol '¤' within the current character set.
  - Custom: any character can be replaced by the Euro symbol within the current character set (use the decimal notation).
- **<Scroll Lock> & <Pause>:** enable or disable these two keys
- **<.;> (numpad):** the two available values are the dot (.) and the comma (,).
- **Backspace Mode:** the two available values are:
  - Standard: move cursor left
  - Suppress: deleting the character on the left of the cursor location
- **Column Separator:** the two possible values are:
  - No: this video attribute is not displayed.
  - Yes: this video attribute is displayed, but due to VGA limitations, it is displayed as underlining.
- **Rulers Style:** the "rule" function allows the cursor to be located easily among other characters. Three types of rules are available:
  - Cross: a horizontal line and a vertical line indicate the cursor location,

- Horizontal: a horizontal line is displayed at the cursor line,
  - Vertical: a vertical line is displayed at the cursor column.
- Press <Rule> (or <Alt Gr><F12> with a PC keyboard) to enable/disable the rule function from a 5250 session.
- **Behavior:** two values:
    - Follows the cursor,
    - Fixed.
  - **Mouse Allowed:** enable/disable the mouse within this session
  - **Local Windowing:** this parameter sets the window display mode. Two values:
    - No: windows are displayed with the original characters ('.' and '!'),
    - Yes: windows are displayed with "real" frames.
  - **Transparent Mode:** this mode allows ASCII data to be sent to auxiliary ports (serial, parallel...). The possible values are:
    - No
    - Yes: data can be encoded in decimal and hexadecimal notations
    - Yes, hexa: data is encoded only in hexadecimal notation.
  - **On/Off ASCII Sequence:** start and stop transparent mode sequence. For more information see Chapter 6.2.5.

#### ***b) Remapping 5250 Functions to any PC Keyboard keys***

This allows any key to be remapped to any 5250 function and/or character string.

Select "Key Mapping" within the 'Session Profile' box and press <Space> to display the following box:

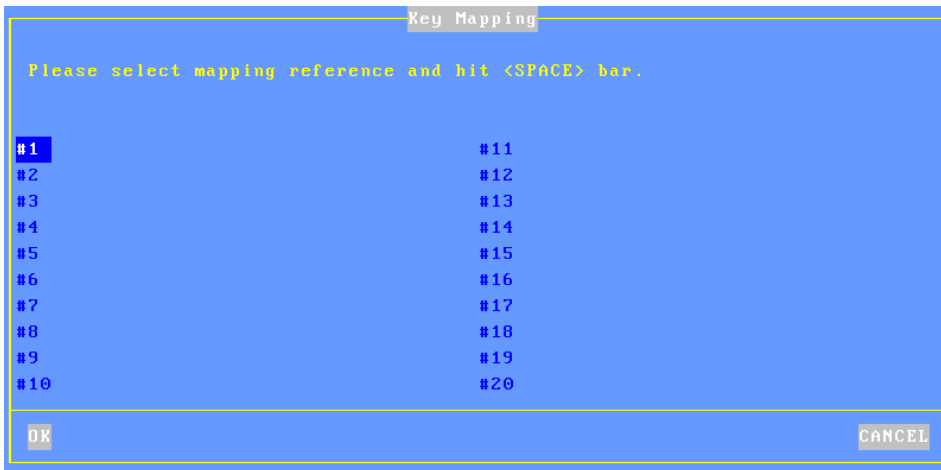

Up to 20 sequences can be remapped (from #1 to #20).

To program a new sequence (or to modify an existing one) select the sequence number and press <Space>. The following dialog box is displayed:

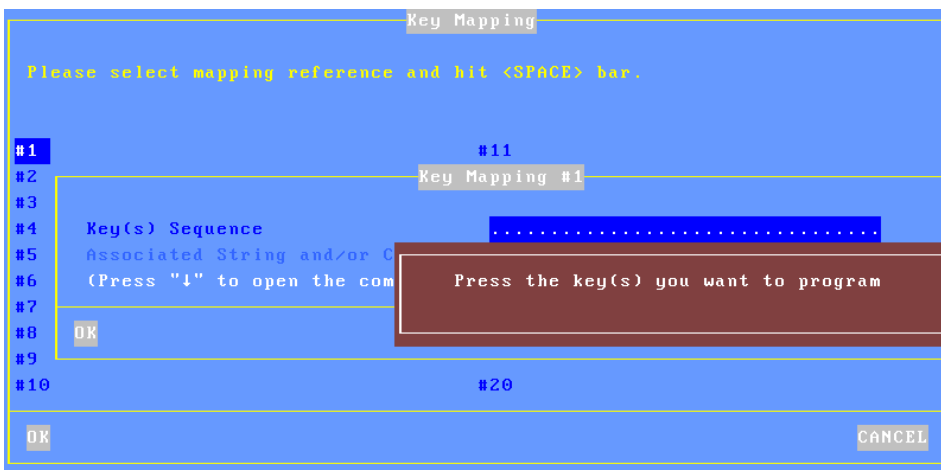



Within the 'Session Profile' box, select 'Palette' and press <Space>. The following box is displayed:

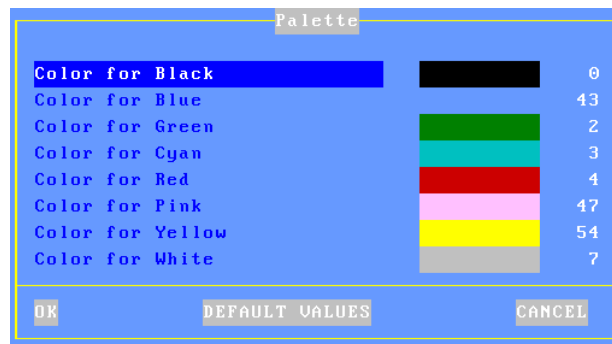

Select one of the 8 emulation colors and press <Space> to select another color.

#### **6.1.5 - Setting-Up the Auto-Signon Function**

Within the 'Session Profile' box, select 'Auto Signon' and press <Space>. The following box is displayed:

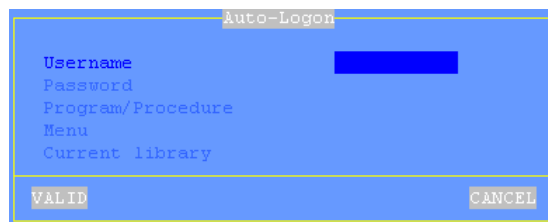

This box allows a value to be entered for each parameter displayed within an AS/400 Signon Screen:

- **Username**
- **Password** (available only if 'Username' is not empty): press <Space> to enter the password.
- **Program/Procedure** (available only if 'Username' is not empty).
- **Menu** (available only if 'Username' is not empty).
- **Current Library** (available only if 'Username' is not empty).

**Important:** the auto-signon function must be allowed at the OS/400 level. To

enable it set the QRMTSIGN variable to \*VERIFY (command CFGTCP).

### **6.1.6 - Connection Properties**

Within the 'Session Profile' box, select 'Connection Properties' and press <Space>. The following box is displayed:

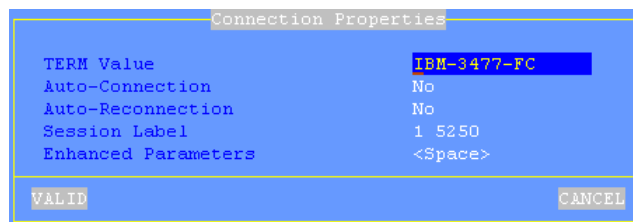

|                     |             |
|---------------------|-------------|
| TERM Value          | IBM-3477-FC |
| Auto-Connection     | No          |
| Auto-Reconnection   | No          |
| Session Label       | 1 5250      |
| Enhanced Parameters | <Space>     |

VALID CANCEL

These parameters are:

- **TERM Value:** terminal capabilities. Default value is IBM-3477-FC.
- **Auto-Connection:** if this parameter is set to 'yes', the connection will be automatically established when the AX3000 is powered. Otherwise, the user can press <Alt><Fx> to establish the connection.
- **Auto-Reconnection:** if this parameter is set to 'yes', a new connection is automatically established after a disconnection. Otherwise, the user can press <Alt><Fx> to establish a new connection.
- **Session Label:** this character string (11 characters max.) is used to identify the session within the session manager or in the status line.
- **Enhanced Parameters:** see Appendix A.10.3.

## **6.2 - USING THE AX3000**

### **6.2.1 - The 5250 Status Line**

**Note:** the 5250 status line is different than the AX3000 TCP/IP status line. (The AX3000 TCP/IP status line displays information about current connected sessions. This line can be enabled/disabled through the AX3000 Set-Up).

The 5250 status line is displayed at the bottom of the screen and gives the following information:

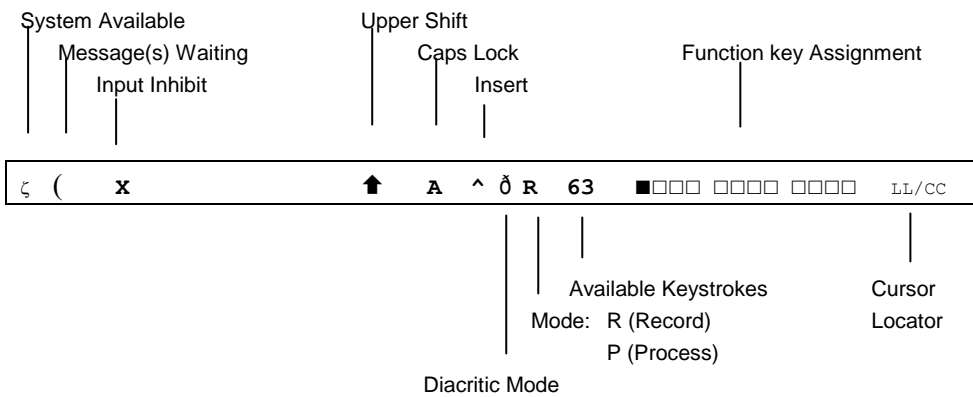

The status symbols are described in the following table.

| Symbol | Name               | Meaning                                                                                                                                                            |
|--------|--------------------|--------------------------------------------------------------------------------------------------------------------------------------------------------------------|
| ζ      | System Available   | The host system is operating and available                                                                                                                         |
| (      | Message(s) Waiting | This symbol, and a beep, indicate the host system has one or more messages for the terminal.                                                                       |
| x      | Input Inhibit      | This symbol is displayed when:<br>- the host system is processing the last input<br>- the host system is very busy<br>- the host system detects an error condition |
| ↑      | Upper Shift        | <Shift> is currently pressed                                                                                                                                       |
| A      | Caps Lock          | The keyboard is in Caps Lock mode                                                                                                                                  |
| ^      | Insert             | The insert mode is enabled (<Inser> key)                                                                                                                           |
| ð      | Diacritic Mode     | This symbol is displayed when the diacritic mode is enabled. This mode is automatically set when a composed character is currently entered (^ + e = ê)             |
| R      | Record             | The "Record" mode is set (see Chapter 6.2.3)                                                                                                                       |
| P      | Process            | The "Process" mode is set (see Chapter 6.2.3)                                                                                                                      |
| LL/CC  | Cursor Locator     | LL and CC indicate the row and column where the cursor is located                                                                                                  |



**6.2.2 - Using the Keyboard**

Two types of keyboard can be used with the AX3000: a PC/AT (102/105-key) or a 5250 (122-key) keyboard. The following tables list the 5250 functions and the Axel functions (entering the set-up, etc) accessed from these keyboard.

**5250 Functions:**

| 5250 Functions              | 5250 Keyboard      | PC/AT Keyboard                    |
|-----------------------------|--------------------|-----------------------------------|
| Attention                   | <Attn>             | <Esc> or <Alt Gr><Pause>          |
| Back tabulation             | < ←> or <Shift><→> | <Shift><Tab>                      |
| Clear end of field          | <ErInp>            | <End>                             |
| Clear all fields            | <Alt><Clear>       | <Pause>                           |
| Cursor shape (Ch. 6.1.3)    | <Cursor>           | <Alt Gr><F11>                     |
| Duplication                 | <Dup>              | <Shift><Insert>                   |
| Enter                       | <Enter>            | <Enter>                           |
| Euro symbol                 | <Alt><E>           | <Alt Gr><E>                       |
| Execute macro               | <Exec>             | <Alt Gr><F5>                      |
| F1...F12                    | <F1>...<F12>       | <F1>...<F12>                      |
| F13...F24                   | <F13>...<F24>      | <Shift><F1>...<Shift><F12>        |
| Fast left                   | <Shift><←>         | <Shift><←>                        |
| Fast right                  | <Shift><→>         | <Shift><→>                        |
| Field -                     | <Field ->          | <-> (numpad)                      |
| Field +                     | <Field +>          | <+> (numpad)                      |
| Field Exit                  | <Field Exit>       | <Entr> (numpad)                   |
| Help                        | <Help>             | <Alt Gr><F1>                      |
| Hexa                        | <Alt><Help>        | <Alt Gr><F7>                      |
| Home of field               | <Alt><Rule>        | <Home>                            |
| New Line                    | <↓>                | <Ctrl Right>                      |
| Print (local mode in PC850) | <Rest><Alt><Print> | <Ctrl><Alt><Prt Scr>              |
| Print (Print HOST mode)     | <Print>            | <Prt Scr>                         |
| Record Macro                | <Record>           | <Alt Gr><F4>                      |
| Reset                       | <Rest>             | <Ctrl Left>                       |
| Roll Down                   | <Shift><↓>         | <Page Up> or <Shift><↓>           |
| Roll Up                     | <Shift><↑>         | <Page Down> or <Shift><↑>         |
| Rule (see Chapter 6.1.3)    | <Rule>             | <Alt Gr><F12>                     |
| System Request              | <Shift><Attn>      | <Shift><Esc> or <Alt Gr><Prt Scr> |
| Tabulation                  | <→>                | <Tab>                             |

**Axel Functions:**

| <b>Axel Function</b>      | <b>5250 Keyboard</b> | <b>PC/AT Keyboard</b> |
|---------------------------|----------------------|-----------------------|
| AX3000 Shutdown           | <Rest><Alt><Del>     | <Ctrl><Alt><Del>      |
| AX3000 Set-Up             | <Rest><Alt><SetUp>   | <Ctrl><Alt><Esc>      |
| Disconnecting the session | <Rest><Alt><D>       | <Ctrl><Alt><Shift><D> |
| Sending data to aux. port | <Alt right><F2>      | <Alt Gr><F2>          |

**6.2.3 - Programming Function Keys (Macro Feature)**

The Axel 5250 emulation allows function keys to be programmed. For example a series of keystrokes can be recorded and played back by pressing a single key.

The recorded data is stored in non-volatile memory so is not affected by switching off.

Recorded keystrokes can be assigned to any of the 24 function keys (<F1> to <F12> or <Shift><F1> to <Shift><F12>).

**a) Programming a Function Key**

To record a series of keystrokes proceed as follows:

- Press **<Alt Gr><F4>** to set the record mode,
- Press any of the 24 function keys to which you want to assign,
- Type the key sequence you want to save,
- Press **<Alt Gr><F4>** to exit the record mode.

**Notes:**

- Memory usage: 256 recordable keystrokes per function key.
- To delete a recorded function key, you have to record an empty key sequence.

Example:

- 1 - Press **<Alt Gr><F4>** to set the Record mode. The 5250 status line is set in reverse video mode and the following information is displayed:
  - Maximum recordable keystrokes for the terminal
  - The 24 boxes are the 24 function keys, a solid box means that data is recorded)

```
MEMOR 127 ■□□□ ■□□□ □□□□ □□□□ □□□□ □□□□ 17/21
```

- 2 - Press one of the function keys (<F1> to <F12> or <Shift><F1> to <Shift><F12>). The 5250 status line is set in normal mode and the following information is displayed:

```
R 256 F1 17/21
```

**Note:** 'R' indicates the Record mode. The second field is the maximum keystrokes that can be recorded for this session. The third field is the selected function key.

- 3 - Type the key sequence.
- 4 - To exit the Record mode, press **<Alt Gr><F4>**.

**b) Processing a Key Sequence**

To execute a series of keystrokes that have been recorded:

- Press **<Alt Gr><F5>** to set the Process mode,
- Press the recorded function key,
- The key sequence is processed.

Example:

- 1 - Press **<Alt Gr><F5>** to set the Process mode. The 5250 status line is set in reverse video mode and the following information is displayed (the 24 boxes are the 24 function keys, a solid box means that data is recorded):

```
EXEC ■□□□ ■□□□ □□□□ □□□□ □□□□ □□□□ 17/21
```

- 2 - Press the recorded function key (<F1> to <F12> or <Shift><F1> to <Shift><F12>). The 5250 status line is set in normal mode and the following information is displayed (the 'P' symbol indicates the Process mode). The key sequence is processed:

```
P 17/21
```

**Note:** during the process mode, the input is inhibited.

### **6.2.4 - The Mouse**

**Note:** the mouse must be enabled. See Chapter 6.1.3.

Four mouse actions are possible:

- **Left-click**, two possible actions are possible depending on the character string under the mouse cursor:
  - If the character string is a function key label, this function key is sent (keystroke emulation).
  - Otherwise the text cursor is moved to the mouse cursor location.
- **Double left-click**, two possible actions are possible depending on the character string under the mouse cursor:
  - If the character string is a function key label, this function key is sent (keystroke emulation).
  - Otherwise the character string + <Enter> are sent (keystroke emulation).
- **Right-click**: roll up is sent (keystroke emulation).
- **Double right-click**: roll down is sent (keystroke emulation).

**Note: identifying the character string under the mouse cursor**

The character string delimiters are:

- Video attributes,
- And the following EBCDIC codes: 00, 40, 4A, 4B, 4C, 4D, 4E, 5A, 5C, 5D, 5E, 60, 61, 6B, 6E, 6F, 7A, 7E, C0 and D0.

Example for the character string "F3=Exit":

- Left-click or double-left-click on "F" or "3": <F3> is sent
- Double-left-click on "E": Exit + <Enter> is sent.

### **6.2.5 - The Transparent Mode**

The transparent mode function allows OS/400 application developers to send ASCII data to the Axcel terminal and/or the auxiliary and logical ports.

The transparent mode can be used with:

- **A screen session** (see Chapter 6.1.4): data is output to specified resource (screen or auxiliary port).  
Example: addressing scales (in conjunction with the ASCII to EBCDIC function).
- **A printer session** (see Chapter 6.3.1): data is output to this session port.

**a) Start and Stop Sequence**

Enable the transparent mode and select the start and stop sequence (default value: @%@)

**b) Operating Mode Rules**

The transparent mode is driven by the following rules:

- For a screen session, enable the transparent mode by sending the transparent sequence (@%@) followed by the port number:
  - 0: default port.
  - 1 to 3: native auxiliary ports (Aux1, Aux2 and parallel)
  - 4 to 5: network printer (Net1 and Net2).
  - 6 to 9: USB logical ports (Usb1, Usb2, Usb3 and Usb4).
- For a printer session, send only the transparent sequence to enable the transparent mode.
- In both case, the transparent mode is disabled when the transparent sequence is sent a second time.
- The character remapping is based on PC850 ASCII table (as with the ASCII to EBCDIC function).

**c) Character or Hexadecimal Mode**

The two transparent modes are:

- **Character Mode:** the dataflow can contain both ASCII characters and hexadecimal ASCII code. The hexadecimal code must began by a / and the ASCII code is encoded by two digit (between 0 and F).  
Example: Esc AB <RC> is \1BAB\0D
- **Hexadecimal Mode:** the dataflow contains only hexadecimal codes (encoded by two digits).  
Example: Esc AB <RC> is 1B41420D

**d) Examples**

With the following examples the start and stop sequence is @%@

**Example 1:** Screen session, character mode

When this EBCDIC data is received:

@%@1/1Bat/2F@@ (44 6C 44 F1 61 F1 C2 81 A3 61 F2 C6 44 6C 44)

This ASCII data is sent to the AUX1 port:

<ESC>at/ (1B 61 74 2F)

**Example 2:** Printer Session, character mode

When this EBCDIC data is received:

@%@/1Bat/2F@@ (44 6C 44 F1 61 F1 C2 81 A3 61 F2 C6 44 6C 44)

This ASCII data is sent to the auxiliary port of this printer session:

<ESC>at/ (1B 61 74 2F)

**e) Handling DTR and RTS Signals**

The transparent mode can also be used to control, from a screen session, DTR and RTS output signals.

The command syntax is the following:

@DTR Port Action

@RTS Port Action

Where:

Port: port numbers are listed in sub-section b

Action: signal is low if this value is 0. Else signal is high.

**6.3 - 5250 PRINTER**

Auxiliary ports, USB logical ports and network printer ports are provided by the AX3000. These ports are independently controlled so multiple printers can be attached to the AX3000.

These printers can be controlled by one of two protocols:

- **Prt5250**: this service (RFC 2877) is OS/400 oriented. A printer controlled by this service is seen as a standard spooled system printer device.
- **LPD**: this service (RFCs 1048 and related) is provided as a standard feature by major operating systems (Unix/Linux, NT, etc.). The main benefit of this protocol is an LPD printer can be shared by different operating systems. But LPD restrictions are:
  - The printer must be manually added to OS/400,
  - The printer is accessed through an outqueue (and not a device),
  - The printer job manipulation is not fully supported.

Normally the Prt5250 protocol is preferred. (No printer declaration is needed at OS/400 level). But the LPD protocol allows the printer to be shared between different operating systems. Choose the protocol which best fits your needs.

**6.3.1 - Setting-Up and Using a Prt5250 Printer**

**a) General Settings**

To set the Prt5250 service, enter the AX3000 Set-Up and select **[Configuration]-[Ports]-[xxx]-[yyy]**.

In the displayed box, set the "Associated Service" to "Prt5250", then select "Net Service Parameters" and press <Space>. The following box is displayed:

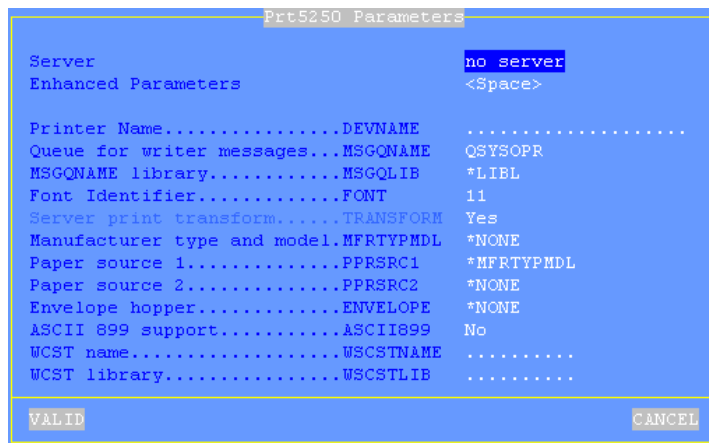

These parameters are:

- **Server:** the server to which the AX3000 opens a printer connection (press <space> to get a list of available servers).  
*This parameter must be entered.*
- **Enhanced Parameters:** access to a group of parameters. The default values of these parameters are suitable for most of the use. See next sub-chapter.
- **Printer Name (DEVNAME):** printer device name.  
*This parameter must be entered*
- **Queue for Writer Messages (MSGQNAME):** message queue name to which the printer messages will be sent.  
*Default value: QSYSOPR*
- **MSGQNAME Library (MSGQLIB):** associate message queue library.  
*Default value: \*LIBL*
- **Font Identifier (FONT):** font number (3, 4 or 5 digits).  
*Default value: 011*
- **Host Print Transform (TRANSFORM):** this parameter is not available. its value is always 'yes'.
- **Manufacturer Type and Model (MFRTYPMDL):** enter the printer driver name (ex: \*NONE, \*HP4, \*NECP2...).  
*Default value: \*NONE*
- **Paper Source 1 (PPRSRC1):** selected through list.  
*Default value: \*MFRTYPMDL*
- **Paper Source 2 (PPRSRC2):** selected through list.  
*Default value: \*NONE*
- **Envelope hopper (ENVELOPE):** describes the paper source 3 (selection through list).  
*Default value: \*NONE*
- **ASCII 899 support (ASCII899):** specifies if the code page ASCII 899 is supported by the printer.  
*Default value: \*NO*
- **WSCST name (WSCSTNAME):** qualified name of the customizing object.
- **WSCST library (WSCSTLIB):** associated library.

**Note:** if the auxiliary port used for printing is a serial port, set the 'Printer' operating mode and set the associated parameters (baud rate, handshake, etc).



### b) Advanced Settings

Within the Prt5250 box select "Enhanced Parameters" and press <Space>. The following dialog box is displayed:

|                       |            |
|-----------------------|------------|
| TCP Port              | 23         |
| TERM                  | IBM-3812-1 |
| Auto-Connection       | Yes        |
| Auto-Reconnection     | Yes        |
| Enhanced Parameters   | <Space>    |
| Transparent mode      | No         |
| On/off ASCII sequence |            |
| VALID                 | CANCEL     |

These parameters are:

- **TCP Port:** OS/400 telnet port. Generally 23.
- **TERM Value:** terminal capabilities. Default value is IBM-3477-FC.
- **Auto-Connection:** if this parameter is set to 'yes', the connection will be automatically established when the AX3000 is powered. Otherwise, the user can press <Alt><Fx> to establish the connection.
- **Auto-Reconnection:** if this parameter is set to 'yes', a new connection is automatically established after a disconnection. Otherwise, the user can press <Alt><Fx> to establish a new connection.
- **Enhanced Parameters:** see Appendix A.10.3.
- **Transparent Mode:** this mode allows ASCII data to be sent to printer session port. The possible values are:
  - No
  - Yes: data can be encoded in decimal and hexadecimal notations
  - Yes, hexa: data is encoded only in hexadecimal notation.
- **On/Off ASCII Sequence:** start and stop transparent mode sequence. For more information see Chapter 6.2.5.

### c) Using the Printer

The Prt5250 service is a client service. This means that each Prt5250 auxiliary port opens a connection to the AS/400 when the AX3000 is powered-on. From the AS/400, a printer is available once the associated Prt5250 connection is established.

A printer handled through the Prt5250 service is seen as a standard spooled OS/400 printer and is managed through standard system commands:

```
===> GO PRINTER
```

#### ***d) In Event of Problems***

**Nothing is printed:** this is a quick test to check the hardware (AX3000 parallel/serial port, cable and printer):

- In the AX3000 Set-Up, select **[Configuration]-[Ports]-[xxx]**. Within the displayed box, select the **[TEST]** button.
- A test banner should be printed.

If not there is a basic hardware problem that needs to be fixed. Check cable, check cable is attached to correct port in back of AX3000 etc.

When the AX3000 printer is not "seen" by the OS/400 spooler the following problems can be suspected.

To establish why a Prt5250 session has been refused, enter the AX3000 Set-Up and select the menu **[Diagnostics]-[Connections]**.

Within the displayed dialog box, select the REFRESH button and press <CR>. Read the information displayed for the printer port (AUX1, AUX2 or PARA).

**Note:** if no information is displayed, double-check that the auxiliary port is associated with the right AS/400 host.

When the connection status continually cycles through CLOSED to CONNECT and there is no error number displayed at the end of the line, the device name is already used by another connection.

If the Prt5250 connection status is 'closed' in the displayed box, an error number is displayed at the end of the line.

The main error codes are:

- **8903** (Device not valid for session): the printer name is used for another connection.
- **8925** (Creation of device failed): during the printer creation operation, at least one parameter is detected wrong (ex.: non-existing printer model).

- **8928** (Change of device failed): during the printer modification operation (reconnection with different parameters), at least one parameter is detected wrong (ex.: non-existing printer model).
- **8930** (Message queue does not exist.): the message queue or its library doesn't exist.
- **AX01** (Terminal type not recognized): the TERM variable (by default IBM-3812-1) associated with the AX3000 auxiliary port is not correct.

**Note:** all possible errors are listed in the RFC 2877.

### **6.3.2 - Setting-Up and Using an LPD Printer**

Set the auxiliary port as shown in Chapter 3.5.2.

To add a system printer invoke the following command (AXPRT01 is the OS/400 printer name):

```
===> CRTDEVPRT DEVD(AXPRT01) DEVCLS(*VRT) TYPE(3812) MODEL(1) FONT(11)
```

To associate this printer with the AX3000 LPD port, you have to change its outqueue:

```
===> CHGOUTQ OUTQ(AXPRT01) RMTSYS(*INTNETADR) RMTPRTO('PARALLEL')  
CNNTYPE(*IP) DESTTYPE(*OTHER) TRANSFORM(*YES) MFRTPMDL(*NECP2)  
INTNETADR('192.168.1.240')
```

Where:

- AXPRT01 : OS/400 outqueue name
- PARALLEL : AX3000 Printer Port Name  
***Uppercase letters are required***
- \*NECP2 : printer model (here a NEC type P2)
- 192.168.1.240 : AX3000 IP address

**Note:** if the outqueue is not started, invoke the STRRMTWTR command.

At the OS/400 level this printer is seen as an outqueue and is not allowed to control it as a device. (For example, it is not possible to start or stop the printer).

## 6.4 - REMOTE ADMINISTRATION

### 6.4.1 - Remote Control

This functionality allows an administrator to remotely take control of a terminal. The administrator can passively watch the users screen or actively take control with his own keyboard for various support or administration purposes.

For more information refer to Chapter 10.2.

### 6.4.2 - Other Functions

☺: A Windows administration utility (AxRM or Axel Remote Management) is available free on the Axel Web site. See Chapter 10.1.

The following commands allow an AX3000 to be controlled over the network.

**Note:** most of the following examples describe the OS/400 command **runrmtcmd**, but remote administration commands can also be invoked with a Unix/Linux or a Windows command (**rsh**).

#### ***a) Rebooting the AX3000***

To reboot an AX3000 over the network, invoke the following command:

```
===> RUNRMTCMD CMD('AX_REBOOT password') RMTLOCNAME('192.168.1.241' *IP)
```

Where:

- AX\_REBOOT : Command for AX3000 reboot,
- password : Specify the set-up password if set,
- 192.168.1.241 : AX3000 IP address.

#### ***b) Resetting an AX3000 resource (screen session or aux. port)***

The reset feature allows:

- To stop and restart the associated network service
- To apply new serial line settings (data transfer rate, handshake, etc.).

The supported resources are:

- Screen sessions: SESS1, SESS2...
- Auxiliary ports: AUX1, AUX2, PARALLEL, NETx and USBx.

Use the following command to reset a resource:

```
===> RUNRMTCMD CMD('AX_SINIT password RESS') RMTLOCNAME('192.1.1.241' *IP)
```

Where:

- AX\_REBOOT : Command for AX3000 resource reset,
- password : Specify the set-up password if set,
- 192.1.1.241 : AX3000 IP address.
- RESS : Resource name (ex: SESS1).

### **c) Editing the AX3000 Settings**

The whole AX3000 set-up can be obtained by invoking the following command:

```
===> RUNRMTCMD CMD(SETUP_GET) RMTLOCNAME('192.168.1.241' *IP)
```

or a partial set-up can also be obtained (only used set-up parameters are sent):

```
===> RUNRMTCMD CMD(SETUP_GET_LITE) RMTLOCNAME('192.168.1.241' *IP)
```

Where:

- SETUP\_GET : Command for getting the whole set-up,
- SETUP\_GET\_LITE : Command for getting the partial set-up,
- 192.168.1.241 : AX3000 IP address.

For more information about these commands, refer to Chapter 10.

### **d) Setting-Up the AX3000**

No OS/400 command allows the contents of a set-up file to be sent over the network. The following example describes the use of rsh Windows command:

```
c:\> rsh 192.168.1.241 setup_send password < /tmp/axel
```

Where:

- 192.168.1.241 : AX3000 IP address,
- setup\_send : Command for set-up the AX3000,
- password : Specify the set-up password if set.

For more information about this command, refer to Chapter 10.

### ***e) Downloading a Firmware***

To download an AX3000 firmware through TFTP:

```
===> RUNRMTCMD CMD('AX_DOWNLOAD password /axfirm/ax3000 192.168.1.180')
RMTLOCNAME('192.168.1.241' *IP)
```

To download an AX3000 firmware through BOOTP and TFTP:

```
===> RUNRMTCMD CMD('AX_DOWNLOAD password /axfirm/ax3000 192.168.1.180')
```

Parameters of the RUNRMTCMD command:

- AX\_DOWNLOAD : Command for firmware downloading,
- password : Required if the set-up is password-protected,
- /axfirm/ax3000 : Path and name of the firmware file,
- 192.168.1.180 : AS/400 IP address,
- 192.168.1.241 : AX3000 IP address.

Messages are displayed on the target AX3000 (See Chapter 11.4).

### ***f) Editing AX3000 Statistics***

Some AX3000 statistics can be obtained by invoking the following command:

```
===> RUNRMTCMD CMD(AX_GETSTAT) RMTLOCNAME('192.168.1.241' *IP)
```

Where:

- AX\_GETSTAT : Command for getting statistics,
- 192.168.1.241 : AX3000 IP address.

## **6.5 - FURTHER OPTIONS**

### **6.5.1 - Turning-Off the AX3000**

Care should be taken before turning off the TCP/IP AX3000 as the AS/400 cannot detect a TCP/IP device being turned-off). For graceful terminal shutdown use the <Ctrl><Alt><Del> keystroke combination.

### **6.5.2 - Reconnection Problem**

If an AX3000 5250 session is set with a specific DEVNAME, problems can occur if it is not cleanly shutdown before being switched off.

If the terminal is powered off without signing off first the As/400 will be unaware the connection is broken and will still consider the connection to be valid and in use. If the terminal then tries to sign on with the same devname the As/400 will refuse connection.

This problem can be solved by tuning '**keepalive**' function of the OS/400 Telnet Server. The keepalive function allows sessions to time out and die after a certain time. Keepalive probes are automatically sent by the OS/400 host when a connection has been idle for a specified time. If the TCP/IP peripheral does not respond, the connection is dropped. The socket is released and applications associated with the connection are killed.

**Note:** to check the status of sockets, use the OS/400 `netstat` command.

By default, the keepalive time out value is very high (sometimes infinite). So this value must be decreased to allow the OS/400 to check regularly the TCP/IP connection status. Invoke the following command to change this value (xxx are seconds):

```
====> CHGTELNA TIMMRKTIMO (xxx)
```

This modification will take effect after restarting the telnet server:

```
====> ENDTCPSVR SERVER (*TELNET)
====> STRTCPSVR SERVER (*TELNET)
```

**IMPORTANT:** using a small keepalive value can prevent routers from dropping the ISDN line and cause high connection bills.





**- 7 -**  
**INSTALLING UNDER OS/390**

*This chapter covers AX3000 installation under OS/390 zSeries.*

This chapter is dedicated to the operation of the AX3000 in the OS/390 environment. For more general information about the AX3000 (network and session settings, instructions for users, etc) please refer to the previous chapters.

## **7.1 - 3270 SCREEN SESSION**

The IBM 3270 emulation type developed by Axel provides all the features of an IBM 3270 terminal. Especially:

- The 3270 telnet protocol (TN3270): compliant with the RFC 1646,
- Enhanced 3270 telnet protocol (TN3270E): compliant with the RFC 2355,
- The device type negotiated by the AX3000 is IBM-3278-2-E:
  - Color support,
  - Screen sizes: 80x24, 80x32, 80x43 and 132x27,
  - 3270 status line.

### 7.1.1 - Setting a Session

To set a profile session, enter the AX3000 Set-Up and select the **[Configuration]-[Sessions]-[Session X]** menu (where X is the session number to be configured). The following box is displayed:

```
Session 1 Profile
-----
Connection Parameters
Session Type          3270
Server                no server
Connection Properties <Space>
Session Parameters
Terminal name (DEVNAME) .....
Display Parameters    <Space>
Additional Parameters  <Space>
Key Mapping           <Space>
Palette               <Space>
-----
OK          RESET          CANCEL
```

These parameters are:

- **Type:** select "3270"
- **Server:** press <Space> to select the server from a list
- **Connection Properties:** pressing <Space> displays a dialog box which lets certain connection parameters be changed. See Chapter 7.1.4
- **Terminal Name (DEVNAME):** this optional name identifies the terminal connection at the OS/390 level.
- **Display Parameters:** press <Space> to set display settings. For more information, see the next chapter.
- **Additional Parameters:** pressing <Space> displays a dialog box which lets certain emulation parameters be changed. See Chapter 7.1.3.
- **Key Mapping:** pressing <Space> displays a dialog box which lets any keys be remapped. See Chapter 7.1.3.
- **Palette:** pressing <Space> displays a dialog box which lets emulation colors be remapped. See Chapter 7.1.3.

Save and exit the set-up. The AX3000 is ready for use.

### **7.1.2 - Display Parameters**

Within the 'Session Profile' box, select 'Display Parameters' and press <Space>. The following box is displayed:

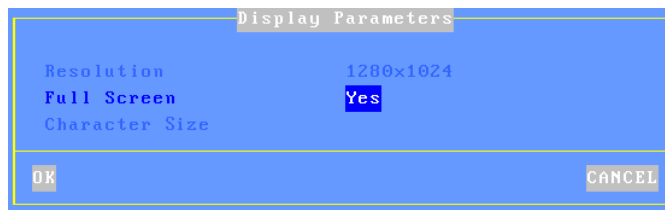

These parameters are:

- **Resolution:** For information only. This is the resolution selected in the [Configuration]-[Terminal]-[Screen] menu.
- **Full Screen:** two possible values:
  - 'Yes': the session is displayed on the entire screen and the character size is automatically adapted to the resolution and the number of lines/columns.
  - 'No': the session is displayed in a 'Window' mode and the character size can be customized.
- **Character Size** (Only when 'Full Screen' is disabled): Two possible values: 'standard' (8x16) or 'double' (16x32).

**Note:** for more information, please refer to Appendix A.10.5.

### **7.1.3 - Customizing the 3270 Emulation**

Various 3270 emulation parameters can be modified but generally the default values are the most suitable.

To customize the 3270 emulation, enter the AX3000 Set-Up and select the session profile ([**Configuration**]-[**Sessions**]-[**Session X**] menu). Three groups of parameters control 3270 emulation settings:

- Additional Parameters: 3270 emulation behavior,
- User-defined Sequences: mapping 3270 functions to any PC keyboard keys.
- Palette: remapping emulation colors.

**a) 3270 Emulation Additional Parameters**

Within the 'Session Profile' box, select 'General Parameters' and press <Space>. The following box is displayed:

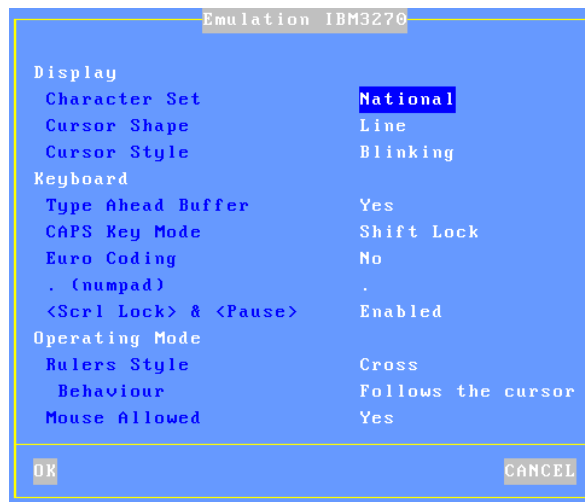

These parameters are:

- **Character Set:** the possible values are:
  - National (characters are keyboard nationality dependent),
  - Multinational.
  - A specific keyboard nationality (American, French...).
- **Cursor Shape:** Line, Half-Block or Block.
- **Cursor Style:** Blinking or Steady
- **Type Ahead Buffer:** enable/disable the keyboard buffer.
- **CAPS Key Mode:** set the CAPS LOCK to behave in either of two ways:
  - Caps Lock: only alphabetical keys are affected. To unlock this mode press the <CAPS> key.
  - Shift Lock: each key sends either the corresponding upper case letter or the shifted (upper) character. To unlock this mode press the <Shift> key.

- Uppercase: each key send the upper character if it is present. Otherwise, this is the lower character (upper-case letter if possible) which is sent. <Shift> key acts in the standard way (whatever the CAPS key). To unlock this mode press the <CAPS> key.
  - Caps Lock +: same as 'Shift Lock'. But in addition ALL the keys supported (including <Esc>, function keys...).
  - **Euro Coding**: Euro symbol support. The three possible values are:
    - No: no specific processing is done
    - Standard: the Euro symbol replaces the international currency symbol '¤' within the current character set.
    - Custom: any character can be replaced by the Euro symbol within the current character set (use the decimal notation to enter the Euro EBCDIC code).
  - **(numpad)**: the two available values are the dot (.) and the comma (,).
  - **<Scroll Lock> & <Pause>**: enable or disable these two keys
  - **Rulers Style**: the "rule" function allows the cursor to be located easily among other characters. Three types of rules are available:
    - Cross: a horizontal line and a vertical line indicate the cursor location,
    - Horizontal: a horizontal line is displayed at the cursor line,
    - Vertical: a vertical line is displayed at the cursor column.
- Press <Rule> (or <Alt Gr><F12> with a PC keyboard) to enable/disable the rule function from a 3270 session.
- **Behavior**: the two values are: "follows the cursor" or "fixed"
  - **Mouse Allowed**: enable/disable the mouse within this session

#### ***b) Remapping 3270 Functions to any PC Keyboard keys***

This allows any key to be remapped to any 3270 function and/or character string.

Select "Key Mapping" within the 'Session Profile' box and press <Space> to display the following box:

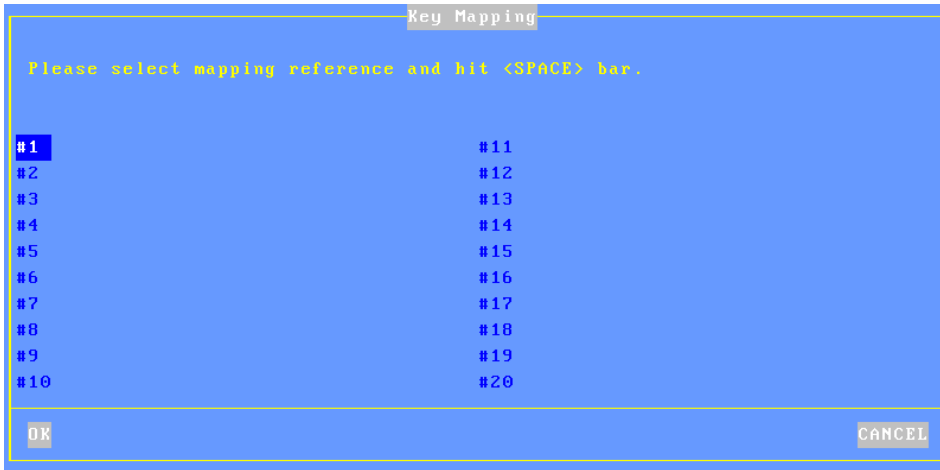

Up to 20 sequences can be remapped (from #1 to #20).

To program a new sequence (or to modify an existing one) select the sequence number and press <Space>. The following dialog box is displayed:

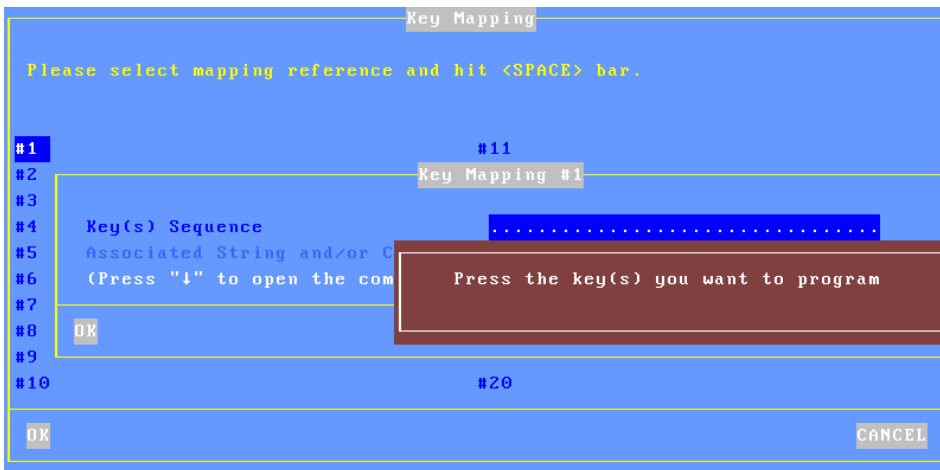

Enter the keystroke to be remapped. Then enter a character string and/or press <Down Arrow> to select through a list the associated 5250 function.

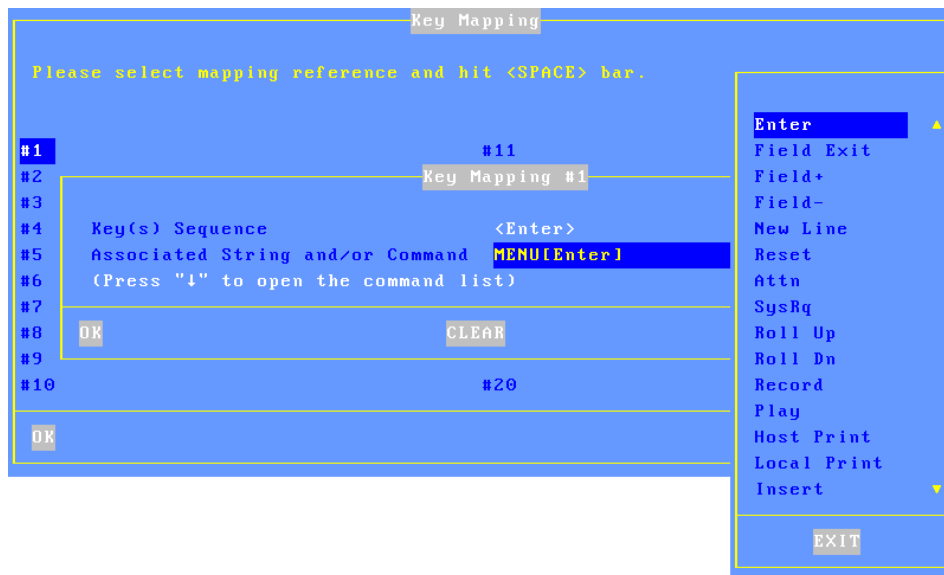

**c) Palette**

This allows default emulation colors to be remapped to any color.

Within the 'Session Profile' box, select 'Palette' and press <Space>. The following box is displayed:

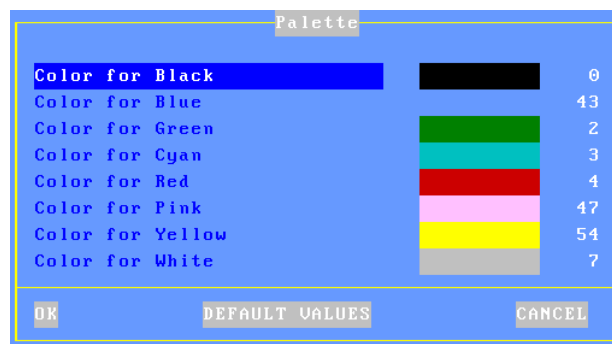



Select one of the 8 emulation colors and press <Space> to select another color.

#### **7.1.4 - Connection Properties**

Within the 'Session Profile' box, select 'Connection Properties' and press <Space>. The following box is displayed:

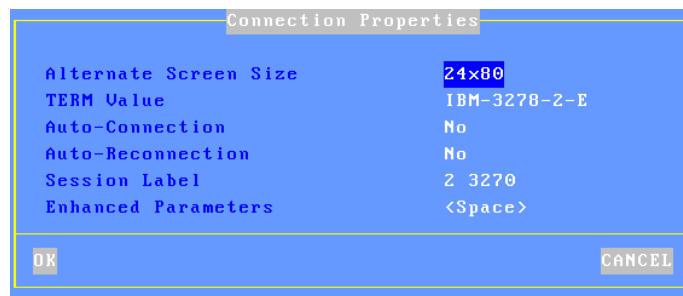

These parameters are:

- **Alternate Screen Size:** possible values are 24x80, 32x80, 43x80 and 27x132. This value set-up a TERM default value.
- **TERM Value:** terminal capabilities. Default value is IBM-3278-2-E.
- **Auto-Connection:** if this parameter is set to 'yes', the connection will be automatically established when the AX3000 is powered. Otherwise, the user can press <Alt><Fx> to establish the connection.
- **Auto-Reconnection:** if this parameter is set to 'yes', a new connection is automatically established after a disconnection. Otherwise, the user can press <Alt><Fx> to establish a new connection.
- **Session Label:** this character string (11 characters max.) is used to identify the session within the session manger or in the status line.
- **Enhanced parameters:** see Appendix A.10.3.

## 7.2 - USING THE TERMINAL

### 7.2.1 - The 3270 Status Line

**Note:** the 3270 status line is different than the AX3000 TCP/IP status line.

The 3270 status line is displayed at the bottom of the screen and gives the following information:

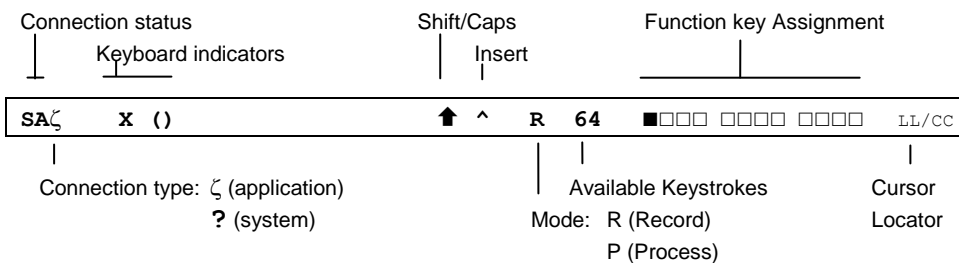

The status symbols are described in the following tables.

#### Connection Symbols

| Symbol | Meaning                                       |
|--------|-----------------------------------------------|
| s      | Connection with host is established           |
| A      | Connection is non-SNA                         |
| ζ      | Connection to an application (Lu-Lu)          |
| ?      | Connection to the system (not an application) |

**Keyboard Symbols**

| Symbol         | Meaning                                             |
|----------------|-----------------------------------------------------|
| <b>X</b> ( )   | Keyboard is disabled                                |
| <b>X</b>       | Only <Enter> is disabled                            |
| <b>X</b> ⤴ >   | Error: too much data entered. Press <Reset>         |
| <b>X</b> ⤴ NUM | Error: numeric value must be entered. Press <Reset> |
| <b>X</b> ← ⤴ → | Error: invalid cursor position. Press <Reset>       |

**Mode Symbols**

| Symbol | Meaning                                                           |
|--------|-------------------------------------------------------------------|
| ⤴      | <Shift> is currently pressed or the keyboard is in Caps Lock mode |
| ^      | The insert mode is enabled (<Insert> key)                         |
| R      | The "Record" mode is set (see Chapter 6.2.3)                      |
| P      | The "Process" mode is set (see Chapter 6.2.3)                     |
| LL/CC  | LL and CC indicate the row and column where the cursor is located |

**7.2.2 - Using a PC/AT Keyboard (102/105 keys)**

The IBM 3270 emulation enables a PC/AT keyboard to be used for operation as a 3270 terminal.

The first twelve 3270 function keys are accessed through <F1> to <F12>. The F13 to F24 function keys are accessed through <Shift><F1> to <Shift><F12>.

The following table lists the other useful keys:

| <b>3270 Functions</b>     | <b>PC/AT keyboard</b>       |
|---------------------------|-----------------------------|
| Fast cursor move to right | <Alt><right arrow>          |
| Fast cursor move to left  | <Alt><left arrow>           |
| Backspace                 | <BackSP>                    |
| Tab                       | <Tab>                       |
| BackTab                   | <Shift><Tab>                |
| Home                      | <Home>                      |
| Newline                   | <Enter>                     |
| EOF                       | <End>                       |
| Erase Input               | <Alt><End>                  |
| Insert mode               | <Insert>                    |
| Delete                    | <Del>                       |
| Duplicate                 | <Shift><Insert>             |
| Field Mark                | <Shift><Home>               |
| System                    | <Alt><Syst> or <Shift><Esc> |
| Attention                 | <Alt><Pause> or <Esc>       |
| Reset                     | <Ctrl left>                 |
| Clear                     | <Pause>                     |
| PA1                       | <PgUp>                      |
| PA2                       | <PgDn>                      |
| PA3                       | <Shift><PgUp>               |
| PF1                       | <F1>                        |
| PF13                      | <Shift><F1> or <Esc>        |
| Enter                     | <Right Ctrl> or <Num Entr>  |
| <Record>                  | <Alt Gr><F4>                |
| <Exec>                    | <Alt Gr><F5>                |
| Euro Symbol               | <Alt Gr><E>                 |
| Rule                      | <Alt Gr><F12>               |

### **7.2.3 - Programming Function Keys (Macro Feature)**

The Axcel 3270 emulation allows function keys to be programmed. For example a series of keystrokes can be recorded and played back by pressing a single key.

The recorded data is stored in non-volatile memory so is not affected by switching off.

Recorded keystrokes can be assigned to any of the twelve function keys (<F1> to <F12>).

**a) Programming a Function Key**

To record a series of keystrokes proceed as follows:

- Press <Alt Gr><F4> to set the record mode,
- Press any of the 12 function keys to which you want to assign,
- Type the key sequence you want to save,
- Press <Alt Gr><F4> to exit the record mode.

**Notes:**

- Memory usage: maximum 256 keystrokes recorded per function key.
- To delete a recorded function key, you have to record an empty key sequence.

Example:

- 1 - Press <Alt Gr><F4> to set the Record mode. The 3270 status line is set in reverse video mode and the following information is displayed (the 12 boxes are the 12 function keys, a solid box means that data is recorded):

```
MEMOR          ■□□□ □□□□ □□□□          17/21
```

- 2 - Press one of the function keys (from <F1> to <F12>). The 3270 status line is set in normal mode and the following information is displayed:

```
R 256 F1          17/21
```

**Note:** 'R' indicates the Record mode. The second field is the maximum keystrokes that can be recorded for this session. The third field is the selected function key.

- 3 - Type the key sequence.
- 4 - To exit the Record mode, press <Alt Gr><F4>.

### b) Processing a Key Sequence

To execute a series of keystrokes that have been recorded:

- Press **<Alt Gr><F5>** to set the Process mode,
- Press the recorded function key,
- The key sequence is processed.

Example:

- 1 - Press **<Alt Gr><F5>** to set the Process mode. The 3270 status line is set in reverse video mode and the following information is displayed (the 12 boxes are the 12 function keys, a solid box means that data is recorded):

```
EXEC          ■□□□ □□□□ □□□□          17/21
```

- 2 - Press the recorded function key (from **<F1>** to **<F12>**). The 3270 status line is set in normal mode and the following information is displayed (the 'P' symbol indicates the Process mode). The key sequence is processed:

```
_____P_____          17/21
```

**Note:** during the process mode, the input is inhibited.

## 7.3 - 3270 PRINTER

Auxiliary ports (2 serial and 1 parallel) and logical ports (USB and TCP) are provided by the AX3000. These ports are independently controlled so multiple printers can be attached to the AX3000.

These printers can be controlled by one of two protocols:

- **Prt3270:** a printer controlled by this service is seen as a standard spooled system printer device.
- **LPD:** this service (RFCs 1048 and related) is provided as a standard feature by major operating systems (Unix/Linux, NT, etc.). The main benefit of this protocol is an LPD printer can be shared by different operating systems.

This chapter describes only the Prt3270 protocol.

To set the Prt3270 service, enter the AX3000 Set-Up and select **[Configuration]-[Aux. Ports]-[xxx]**.

In the displayed box, set the "Associated Service" to "Prt3270", then select "Net Service Parameters" and press <Space>. The following box is displayed:

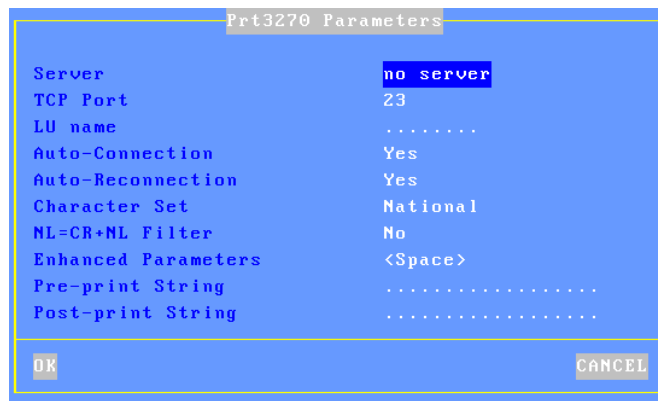

These parameters are:

- **Server**: the server to which the AX3000 opens a printer connection (press <space> to get a list of available servers).  
*This parameter must be entered.*
- **TCP PORT**: telnet port of the S/390 server. Default is 23.
- **LU Name**: system printer name.
- **Auto-Connection**: set to yes.
- **Auto-Reconnection**: set to yes.
- **Character Set**: the possible values are:
  - National (characters are keyboard nationality dependent),
  - Multinational.
  - A specific keyboard nationality (American, French...).
- **NL=CR+NL Filter**: The line feed character (0x0A) can be mapped to carriage return + line feed (0x0D + 0x0A),
- **Enhanced parameters**: see Appendix A.10.3.
- **Pre-print String**: character string sent before the printing.
- **Post-print String**: character string sent after an the printing (for example "\0C" is a form feed)

**Note 1:** If "Choose Portrait/Landscape" is enabled (see Appendix A.10.2), the

parameter "**Pre-print String**" is replaced by the two parameters "**Portrait Pre-print String**" and "**Landscape Pre-print String**".

**Note 2:** if the auxiliary port used for printing is a serial port, set the 'Printer' operating mode and set the associated parameters (baud rate, handshake, etc).

## **7.4 - REMOTE ADMINISTRATION**

### **7.4.1 - Remote Control**

This functionality allows an administrator to remotely take control of a terminal. The administrator can passively watch the users screen or actively take control with his own keyboard for various support or administration purposes.

For more information refer to Chapter 10.2.

### **7.4.2 - Other Functions**

The remote administration command is rsh (or rexec). This command is available with most of operating systems.

☺: A Windows administration utility (AxRM or Axel Remote Management) is available free on the Axel Web site. See Chapter 10.1.



**- 8 -**

**INSTALLING UNDER UNIX/LINUX**

This chapter covers AX3000 installation under Unix/Linux.

## 8.1 - TEXT MODE SESSION (TCP/IP OR SERIAL MODE)

### 8.1.1 - Setting a Session Profile

To set the profile of a session, enter the AX3000 Set-Up and select the **[Configuration]-[Sessions]-[Session X]** menu (where X is the session number to be configured). The following box is displayed:

```
Session 1 Profile
Connection Parameters
Session Type      Text Emulation
Emulation        ANSI
Protocol         telnet
Server           no server
Connection Properties  <Space>
Session Parameters
Display Parameters  <Space>
Additional Parameters  <Space>
Editing Keyboard Table  <Space>
Key Mapping        <Space>
Coloring Mode     Disabled
Coloring Mode Settings
Palette           <Space>
OK              RESET              CANCEL
```

These parameters are:

- **Session Type**: select 'Text Emulations'.
- **Emulation**: see Chapter 8.1.3

- **Protocol:** select 'telnet', 'tty', 'ssh', 'ssh2', 'aux1' or 'aux2'. (See Chapter 8.1.2)
- **Server:** press <Space> to select the server from the list
- **Connection Properties:** pressing <Space> displays a dialog box which allows certain connection parameters to be changed. (See Chapter 8.1.8)
- **Display Parameters:** press <Space> to set display settings. For more information, see Chapter 8.1.4.
- **Additional Parameters:** pressing <Space> displays a dialog box which allows certain emulation parameters to be changed. (See Chapter 8.1.5)
- **Editing Keyboard table:** pressing <Space> displays a dialog box which allows certain keys to be remapped. (See Chapter 8.1.5)
- **Key Mapping:** pressing <Space> displays a dialog box which allows all of the keys to be remapped. (See Chapter 8.1.5)
- **Coloring mode:** this function allows monochrome applications to be displayed in color. (See Chapter 8.1.6)
- **Palette:** pressing <Space> displays a dialog box which lets colors to be remapped. (See Chapter 8.1.5)

Save and exit. The AX3000 is ready for use.

### **8.1.2 - Protocols: telnet, tty, ssh, ssh2 or aux1/aux2**

Connecting a character based session can be done:

- Either in TCP/IP mode via **telnet**, **tty** or **ssh** protocols
- Or in serial mode (RS232) by using a serial port (Aux1, Aux2...)

#### ***a) The TELNET Protocol***

The telnet server is a standard module of the Unix/Linux TCP/IP stack. The AX3000 can immediately open a client telnet session, without any additional software or alteration to the Unix/Linux settings.

Main characteristics of a telnet session:

- Dynamic allocation of pseudo-terminals (pty),
- System access is controlled by a 'login', which is generated by the telnetd daemon,
- The value of the TERM environment variable is negotiated after the login stage. (See Chapter 8.1.8 for default TERM values.)

**b) The TTY Protocol**

The tty server is an Axel proprietary protocol. Additional software is required (see Chapter 8.4).

Main characteristics of a tty session:

- Pre-defined allocation of pseudo-terminals (ptty),
- UNIX access is controlled by a 'login', which is generated by the init daemon (controlled by the **/etc/inittab** file).

The Unix/Linux host must run the AXEL tty server daemon (**axttyd**). The configuration file **axttyd** must contain a list of AX3000 sessions and the ptty's associated with each.

Each session is identified by the name of the AX3000 (from the **/etc/hosts** file) and a special keyword (**sessx** where **x** is the session number). For example:

|       |       |             |             |
|-------|-------|-------------|-------------|
| axel1 | sess1 | /dev/ptyp12 | /dev/ttyp12 |
| axel1 | sess2 | /dev/ptyp13 | /dev/ttyp13 |
| axel2 | sess2 | /dev/ptyp2  | /dev/ttyp2  |

A terminal session controlled by the tty server acts as a serial terminal attached to a multi I/O board. The **/etc/inittab** file must therefore be modified to launch the **getty** command for each pseudo-terminal.

Example for SCO Unix: get a login on **/dev/ttyp12**:

```
p12:23:enable:/etc/getty -t60 /dev/ttyp2 m
```

This modification will take effect after invoking the following command:

```
# init q <CR>
```

For more information about the Axel tty server, refer to Chapter 8.4.

### c) The SSH/SSH2 Protocol

An SSH connection can be considered as an encrypted telnet connection. Main characteristics are:

- Dynamic allocation of pseudo-terminals (pty),
- System access is controlled by a 'login', which is generated by the sshd daemon (available with most versions of Unix/Linux),
- The value of the TERM environment variable is negotiated after the login stage. (See Chapter 8.1.8 for default TERM values.)

Notes:

- The Axel SSH client is compliant with OpenSSH.
- The SSH2 protocol is only available for Model 80 and 85.

To accept Axel SSH connections, the SSH server must support the password authentication mechanism. In addition when the ssh (v1) protocol is used the server must accept connections from SSH V1 clients. These two functions are indicated in sshd\_config file by:

```
Protocol 2,1
PasswordAuthentication yes
```

### d) Serial Ports (Aux1, Aux2...)

The Axel terminal supports both TCP/IP and serial (RS232) connections.

To establish a serial connection, the session 'Protocol' must be set to 'serial'. Then set 'Main Serial Port' to a native serial ports or an USB serial port.

The selected auxiliary port is set-up through the **[Configuration]-[Ports]-[xxx]-[yyy]** menu (see Chapter 3.5.1).

### 8.1.3 - Selecting the Emulation

The available emulations are:

```
ANSI
SCO OPENSERVER
UNIX SVR4
ANSI RS 6000
UNIXWARE 7
LINUX
VT100/220
VT52
WYSE 50/60/120
ADDS VP-A2 Enhanced
ADDS VP-60 Enhanced
3151
Others...
```

```
ANSI DOS
UNIX SCO 3.2.2
UNIX SCO 3.2.4
XENIX SCO
ANSI DATA GENERAL
ANSI INTERACTIVE
UNIXWARE 7
ATO300
PRISM
REAL/32
THEOS
OS2 POLYMOD2
SM9400
SM9412
TWIN SERVER
PROLOGUE 3
TVI 950
QVT119+
AMPEX+
C332
```

The following table shows the recommended emulations for the various operating systems:

| Operating Systems | Pre-defined Configuration |
|-------------------|---------------------------|
| UNIX SCO 3.2v2    | UNIX SCO 3.2.2            |
| UNIX SCO 3.2v4    | UNIX SCO 3.2.4            |
| Open Server SCO   | SCO OPENSERVER            |
| XENIX SCO         | XENIX SCO                 |
| IBM AIX 3.x       | ANSI RS6000               |
| IBM AIX 4.x       | HFT                       |
| Unix Ware 7       | UNIXWARE 7                |
| LINUX             | LINUX                     |
| UNIX Interactive  | ANSI INTERACTIVE          |
| SUN - Solaris 2.x | ANSI SVR4                 |
| Others            | ANSI, VT220 or WYSE 60    |

**Note:** selecting emulation sets the value of the TERM environment variable (see Chapter 8.1.8). This value can be modified later if necessary.

### 8.1.4 - Display Parameters

Within the 'Session Profile' box, select 'Display Parameters' and press <Space>. The following box is displayed:

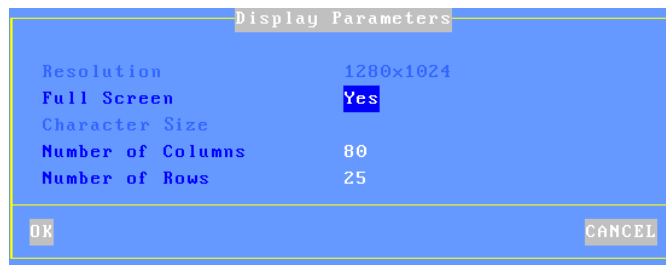

These parameters are:

- **Resolution:** For information only. This is the resolution selected in the [Configuration]-[Terminal]-[Screen] menu.
- **Full Screen:** two possible values:
  - 'Yes': the session is displayed on the entire screen and the character size is automatically adapted to the resolution and the number of lines/columns.
  - 'No': the session is displayed in a 'Window' mode and the character size can be customized.
- **Character Size** (Only when 'Full Screen' is disabled): Two possible values: 'standard' (8x16) or 'double' (16x32).
- **Number of Columns:** three possible values: 40, 80 or 132.
- **Number of Rows:** enter a value between 24 and 44.

**Note:** for more information, please refer to Appendix A.10.5.

### 8.1.5 - Customizing the Emulation

Various emulation parameters can be modified but generally the default values are the most suitable. Three groups of parameters control emulation settings:

- Additional Parameters: emulation behavior.
- Editing Keyboard Table: associating character strings to certain keyboard keys.
- Key Mapping: associating character strings to any keyboard keys.
- Palette remapping emulation colors.

**a) Emulation Additional Parameters**

Within the 'Session Profile' box, select 'General Parameters' and press <Space>. The following box is displayed:

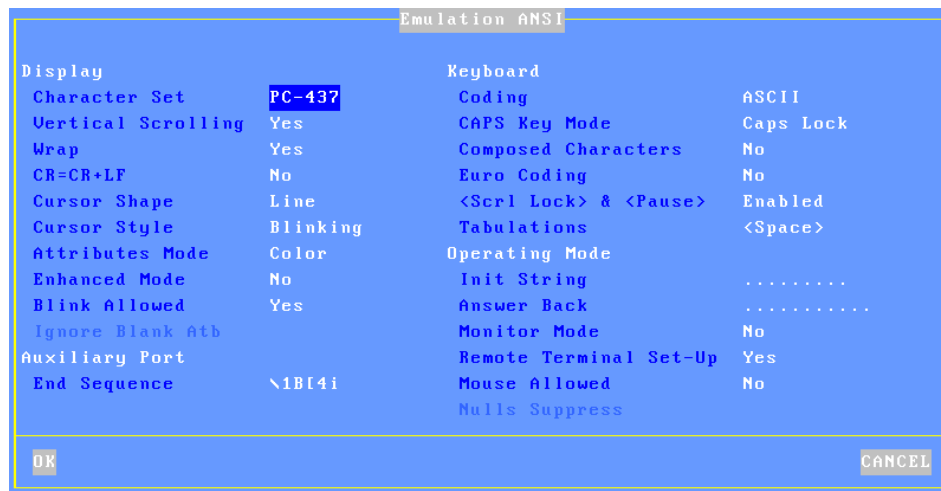

These parameters are:

- **Character Set:** the available character sets depend on which emulation is selected.
- **Vertical Scrolling:** whether the AX3000 display scrolls, when the cursor is moved down passed the bottom of the screen:
  - Yes: the display scrolls up
  - No: the cursor re-appears on the first (top) line.
- **Wrap:** behavior of the AX3000 when the cursor reaches the last column of the screen:
  - Yes: the next characters wrap round onto the start of the next line
  - No: each new character overwrites the last character on the line.
- **CR=CR+LF:** AX3000 behavior when 0x0Dh is received:
  - Yes: 0x0D is mapped to 0x0D and 0x0A
  - No: no specific processing is done
- **Cursor Shape:** Line, Half-Block and Block.
- **Cursor Style:** Blinking or Steady.
- **Attributes Mode:** VGA monitor mode. The two values are "color" and "monochrome" (which allows underline attribute to be displayed).



- **Enhanced Mode:** enable or disable the display of double-size characters or color underline attribute.
- **Blink Allowed:** if blink attribute is disabled, 16 background colors can be used (instead of the 8 normally available).
- **Ignore Blank Atb** (WYSE emulation only): if 'yes', the blank attribute is not processed (example: normal+blank=normal).
- **End Sequence:** to stop transparent printing mode
- **Coding:** two keyboard modes are available (ASCII and scancode).
- **CAPS Key Mode:** set the CAPS LOCK to behave in either of three ways:
  - Caps Lock: each alphabetical key sends the corresponding upper case letter. To unlock this mode press the <CAPS> key.
  - Shift Lock: each key send the same character sent by pressing <Shift><This key>. To unlock this mode press a <Shift> key.
  - Uppercase: each key send the upper character if it is present. Otherwise, this is the lower character (upper-case letter if possible) which is sent. <Shift> key acts in the standard way (whatever the CAPS key). To unlock this mode press the <CAPS> key.
  - Caps Lock +: same as 'Shift Lock'. But in addition ALL the keys supported (including <Esc>, function keys...).
- **Composed Characters** : this parameter (only available in ASCII mode) sets the keyboard behavior for diacritical characters (for example: ^ + e = ê):
  - No: no specific processing is done
  - Local: composite characters are locally processed by the AX3000
  - Remote: SCO specific mode (mapchan).
- **Euro Coding:** this parameter is only available if the current character set is not PC858 or ISO8859-15 (These 2 character sets include the Euro symbol). The three values are:
  - No: no specific processing is done
  - Standard: the Euro symbol replaces the international currency symbol '¤' within the current character set.
  - Custom: any character can be replaced by the Euro symbol within the current character set (use the decimal notation to enter the Euro ASCII code).
- **<Scroll Lock> & <Pause>:** enable or disable these two keys
- **Tabulations:** a dialog box appears in which tab stops can be set.
- **Init String:** this character string is sent when the session (telnet or tty) is established.
- **Answer Back:** session identifier (10 character max.).



There are three groups of programmable keys:

- From F1 to F48: function keys used singly or with a modifier key. Example for ANSI emulations:
  - F1 to F12: <Fx>
  - F13 to F24: <Shift><Fx>
  - F25 to F36: <Ctrl><Fx>
  - F37 to F48: <Ctrl><Shift><Fx>
- Numeric pad with Number Lock off
- Special keys: Esc, Backspace and the 'dot' of the numeric pad.

To enter a programmable key value select the key label then press <Space>. The following dialog box is displayed:

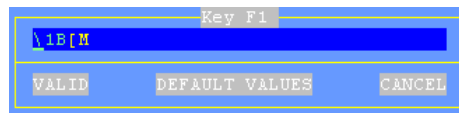

The main field is used to enter the programmable key value. ASCII codes lower than 20h can be entered as '\xx' (where xx is the hexadecimal value of the ASCII code).

**Note:** for the 'Backspace' key and the numeric pad dot, a toggle is only available (two possible values for each key).

Memory usage is limited to 256 bytes maximum per key.

### ***c) Key Mapping***

This function allows any key to be remapped into any value (only available for ASCII keyboard mode)

Select "Key Mapping" within the 'Session Profile' box and press <Space> to display the following box:

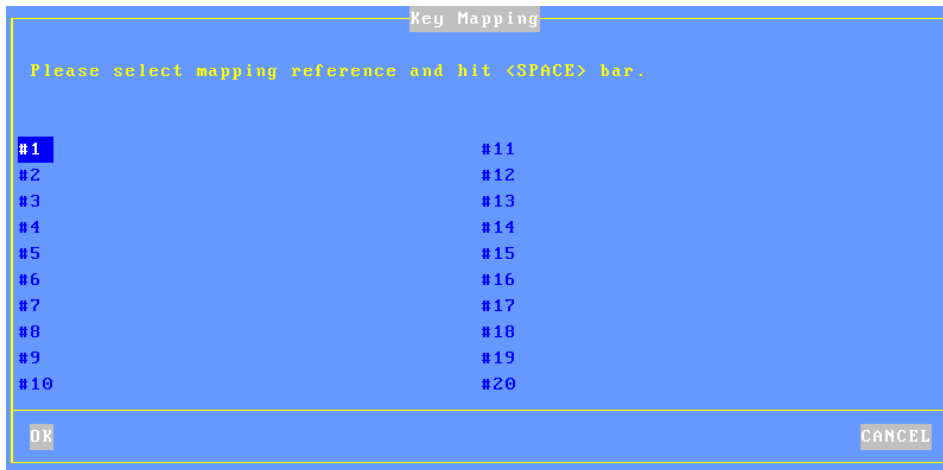

Up to 20 sequences can be remapped (from #1 to #20).

To program a new sequence (or to modify an existing one) select the sequence number and press <Space>. The following dialog box is displayed:

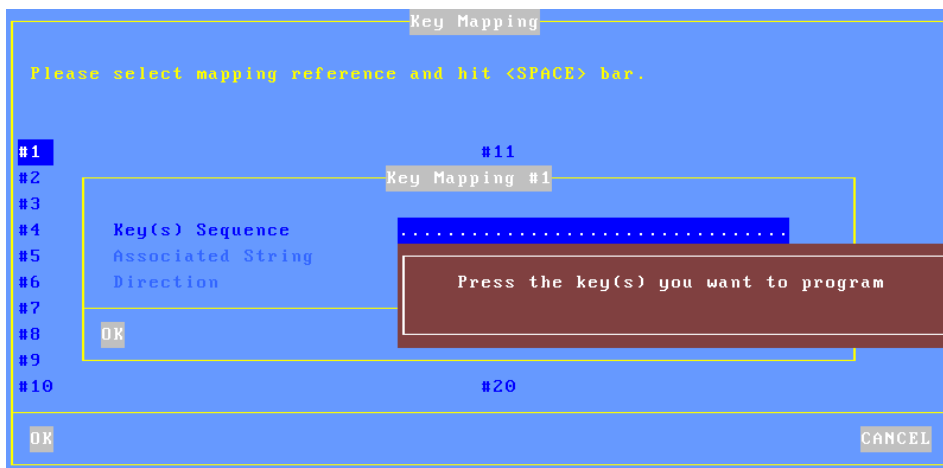

Enter the keystroke to be remapped (parameter **Key(s) Sequence**).

Other parameters:

- **Associated String**: enter the value associated with the key sequence. ASCII codes lower than 20h can be entered as '\xx' (where xx is the hexadecimal value of the ASCII code).
- **Direction**: two possible values:
  - Remote: when the key sequence is pressed, the 'Associated String' is sent to the server.
  - Local: when the key sequence is pressed, the 'Associated String' is interpreted by the terminal (as if the string had been sent by the server).

#### d) Palette

This allows default emulation colors to be remapped to any color.

Within the 'Session Profile' box, select 'Palette' and press <Space>. The following box is displayed:

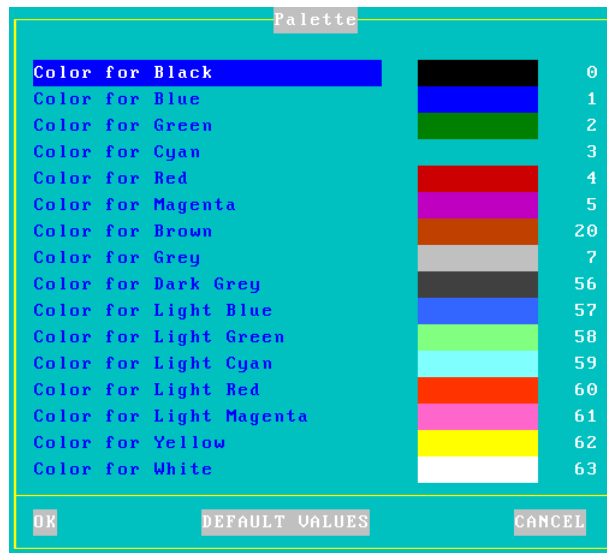

Select one of the 16 emulation colors and press <Space> to select another

color.

### **8.1.6 - Coloring Mode**

A background color, plus a foreground color for each monochrome character attribute or graphics character, may be set through the Coloring Mode. This function allows monochrome applications to be displayed in color.

The "**Coloring Mode**" parameter offers 2 values:

- Standard: 6 coloring attributes
- Enhanced: 16 coloring attributes

To customize the coloring mode, select the "**Coloring Mode Settings**" parameter and press <Space>. The dialog box depends on which coloring mode is chosen.

#### ***a) Standard Coloring Mode***

The dialog box for the standard coloring mode is:



The available coloring attributes are normal, reverse video, underline, semi-graphics and blink (optional).

To set a coloring attribute, select and press **<CR>**. The following dialog box appears:

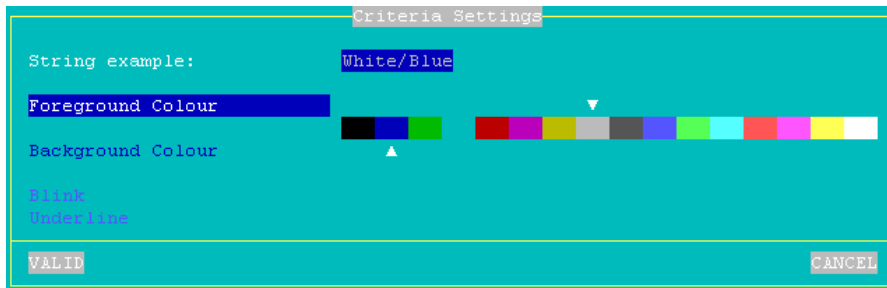

**Note:** the blink and underline parameters are disabled in standard coloring mode.

#### ***b) Enhanced Coloring Mode***

This mode enables background color, foreground color and the display of the underline and blink to be set for all attributes.

Example: the multiple attribute **Blink+Reverse** can be displayed with red foreground, green background, no blinking and underline enabled.

The dialog box for enhanced coloring mode is:

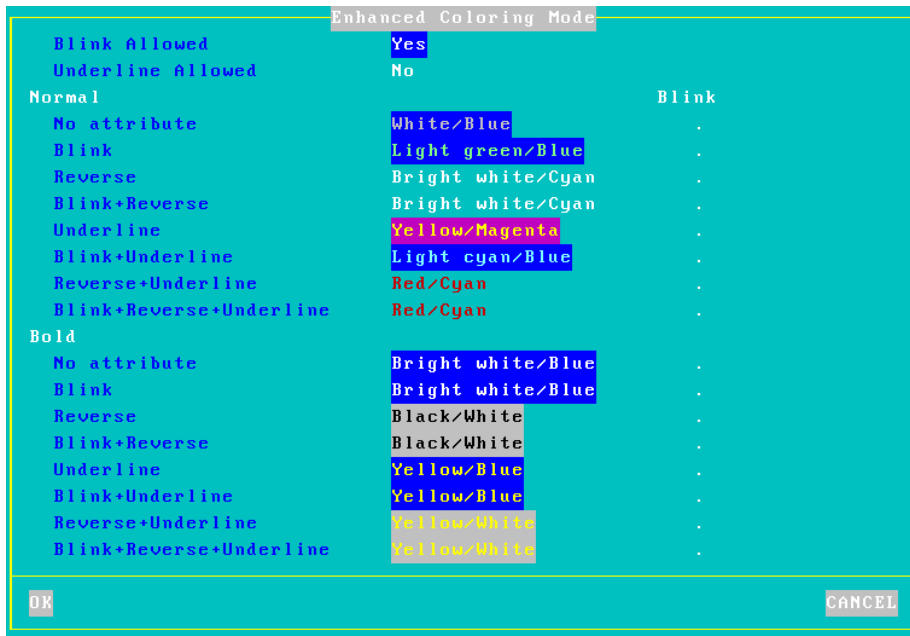

Coloring mode parameters:

- **Blink allowed:** if this parameter is set to 'no', 16 background colors are available. Otherwise, only 8 background colors are allowed.
- **Underline allowed:** if this parameter (which requires enhanced mode) is set to 'yes', the underline attribute can be displayed but only 8 foreground colors are available. Otherwise, there is no underline attribute but 16 foreground colors.



To set a coloring attribute, select and press <CR>. The following dialog box appears:

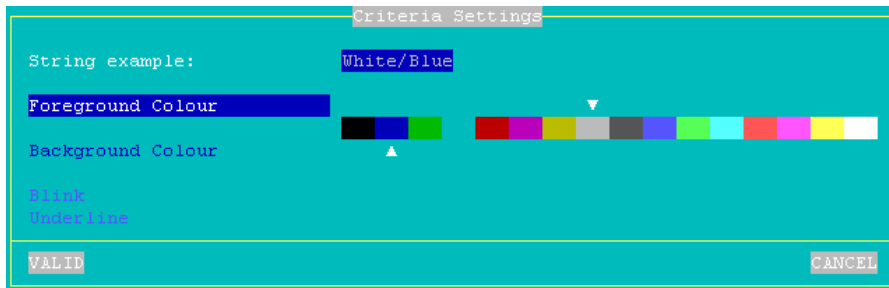

Depending on the **Blink allowed** and **Underline allowed** parameters, 8 or 16 foreground and background colors are available and the **Blink** and **Underline** parameters are either enabled or disabled.

**8.1.7 - Underline Attribute Management**

The reverse video attribute, the bold attribute and the blinking attribute are supported by all VGA monitors. However, the underline attribute is only supported by monochrome VGA monitors.

If the underline attribute is essential with a color VGA monitor, one of the following three methods can be used, but note that each entails the loss of some other display capability.

**a) Using the Session as a Monochrome Session**

Set the **Attribute Mode** parameter to **monochrome** (see Chapter 8.1.5).

**b) Using the Coloring Mode**

The AX3000 coloring mode is used to provide different foreground and background colors for each monochrome attribute. So although no underline appears on the screen, normal and underlined text can be distinguished by different background colors.

The benefit of this method is that the coloring mode is specific to a single session. Sessions with different colors, or with the native colors of a software package, can be run on the same AX3000.

For more information about "coloring mode", see Chapter 8.1.6.

### ***c) Using Underline Attribute in Color Mode***

An AX3000 set-up parameter allows the underline attribute to be displayed in color mode, but this disables the bold attribute.

This is a good way to display underlining if the bold attribute is not used by the software in question.

Enter the AX3000 set-up and set for the required session the '**Enhanced Mode**' parameter to '**Yes**'. See Chapter 8.1.5.

### **8.1.8 - Connection Properties**

Within the 'Session Profile' box, select 'Connection Properties' and press <Space>. The following box is displayed:

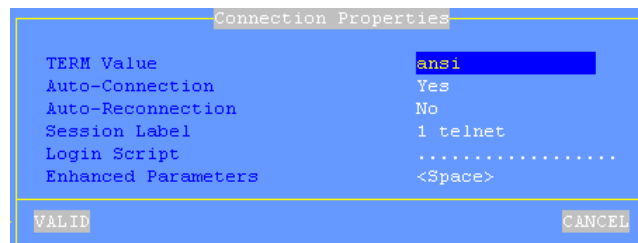

| Parameter           | Value    |
|---------------------|----------|
| TERM Value          | ansi     |
| Auto-Connection     | Yes      |
| Auto-Reconnection   | No       |
| Session Label       | 1 telnet |
| Login Script        | .....    |
| Enhanced Parameters | <Space>  |

VALID CANCEL

These parameters are:

- **TERM Value** (telnet and ssh protocols). The value of this environment variable is 'negotiated', between the host and the AX3000. The following table shows the default values according to the emulations:

| Emulation           | TERM        |
|---------------------|-------------|
| ANSI                | ansi        |
| SCO OPENSERVR       | ansi        |
| UNIX SVR4           | AT386       |
| ANSI RS6000         | hft-c-old   |
| UNIXWARE 7          | AT386-ie    |
| LINUX               | linux       |
| VT100/VT220         | vt220       |
| VT52                | Vt52        |
| WYSE 60             | wyse 60     |
| ADDS VP-A2 Enhanced | viewpoint   |
| ADDS VP-60          | viewpoint60 |
| 3151                | lbm3151     |
| ANSI DOS            | ansi        |
| UNIX SCO 3.2.2      | ansi        |
| UNIX SCO 3.2.4      | ansi        |

| Emulation         | TERM        |
|-------------------|-------------|
| XENIX SCO         | ansi        |
| ANSI DATA GENERAL | ansi        |
| ANSI INTERACTIVE  | AT386       |
| ATO300            | vt220       |
| PRISM             | prism       |
| REAL/32           | ---         |
| THEOS             | CLASS185    |
| OS2 POLYMOD2      | CLASS185    |
| SM94xx            | in9400-uv   |
| TWIN SERVER       | twin server |
| PROLOGUE 3        | prl3        |
| TVI 950           | tvi950      |
| QVT119+           | qvt119+     |
| AMPEX+            | ampex       |
| C332              | C332        |

- **Auto-Connection:** if this parameter is set to 'yes', the connection will be automatically established when the AX3000 is powered. Otherwise, the user can press <Alt><Fx> to establish the connection.
- **Auto-Reconnection:** if this parameter is set to 'yes', a new connection is automatically established after a disconnection. Otherwise, the user can press <Alt><Fx> to establish a new connection.
- **Session Label:** this character string (11 characters max.) is used to identify the session within the session manger or in the status line.
- **Login Script:** a "login script" can be set to automatically enter user names and passwords at the login prompt. See Chapter 8.1.9.
- **Enhanced parameters:** see Appendix A.10.3.

**8.1.9 - Login Script**

The "login script" can be set to automatically enter user names and passwords at the login prompt.

**a) Enabling a Login Script**

To associate a login script with a session, within the 'Session Profile' box select

"Connection Properties" and press <Space>. In the displayed box (see Chapter 8.1.8) select "Login Script".

The login script is a character string with the following characteristics:

- Maximum 60 characters.
- The string is composed of tokens. The NULL character (encoded by \00) is used as a token-separator. A string must contain an even number of tokens.
- Any character except a NULL can compose a token.
- A string can contain as many tokens as needed.
- Odd tokens are characters expected by the AX3000.
- Even tokens are characters sent by the AX3000 after the expected token has been received.

A login script looks like:

```
aaaaaa\00bbbbbb\00cccccc\00dddddd
```

### ***b) Example***

With the following script:

```
login:\00root\0D\00password:\00mypwd\0D
```

When the session is opened (<Alt><Fx>), the AX3000 acts as:

- Waiting for "login:".
- After "login:" has been received, the AX3000 sends "root"+<CR>. **Note:** as for the programmable keys, ASCII codes lower than 20h can be entered as '\xx' (where xx is the hexadecimal value of the ASCII code. Examples: Escape is \1B and <CR> is \0D.
- Waiting for "password:".
- After "password:" has been received, the AX3000 sends "mypwd"+<CR>.

**Note:** whilst a login script is running, the AX3000 keyboard is locked. In the event of a problem (wrong expected token), press <Esc> to skip the login script and to unlock the keyboard.

### **8.1.10 - The Multi-Shell**

The AXEL multi-shell software allows multiple telnet sessions on the same host, with the same user name, without demanding multiple logons. This is done by

running the AXEL **tcpmsh** program from a UNIX shell. This supports up to eight duplicated sessions.

**Operating example:** you could run four multi-shell sessions (or «views») across each of two telnet connections to different hosts. Function keystroke combinations could be used to hot-key between the different telnet connections (<Alt><Fx>) and different multi-shell views (<Ctrl><Fx>).

### **a) Installation**

Copy to **/usr/bin** and rename as 'tcpmsh' the appropriate binary. Example for IBM AIX:

```
# cp tcpmsh.AIX /usr/bin/tcpmsh <CR>
```

### **b) Setting-Up the AX3000**

Use of multiple views within a single telnet session must be set through the AX3000 set-up.

The AX3000 supports eight virtual screens, which may be shared, between telnet sessions and multi-shell views. In the AX3000 set-up, multi-shell views are referred to as «pages per session» or «page/session».

The AX3000 default factory set-up is 6 telnet sessions and 1 page/session.

To change this configuration, enter AX3000 Set-Up (<Ctrl><Alt><Esc>) and tune the **number of sessions** and **number of Pages/Session** parameters.

### **c) Using the Multi-Shell**

To run tcpmsh, the syntax is:

```
$ tcpmsh [-options] <CR>
```

The main tcpmsh options are:

- **b**: selecting generic names of pseudo-terminals:
  - b 0 (default): using ttypx (x is any decimal value from 0 to 63),
  - b 1: using ttypx (x is any hexadecimal value from 0 to 3Fhex),

- **b 2**: using `ttypx`, `tyqx`, `ttyrx` and `ttysx` (`x` is any hexadecimal value from 0 to F).
- **c**: a different overscan color is associated with each view
- **f file**: initial commands. This command file has a maximum of eight lines. Each line lists the command associated with one view. If a view does not have an initial command, its associated line must start with a dash character (2Dhex character)
- **h**: online help
- **L label**: each view is associated with the character string 'label/n' (is `n` is the view number. This label is displayed on the TCP/IP status line.
- **l**: the line 25 acts as a status line which specifies the active session and the number of declared views.
- **m**: silent mode
- **n nbr**: maximum number of view (default 2).
- **p file**: fixed set of `ttyp`. This file has a maximum of eight lines. Each line lists the `ttyp` **slave part** associated with one view.
- **S str**: `str` is the required shell (`sh`, `ksh`, etc).
- **x nbr**: `nbr` is the size of each circular buffer associated with one view.

When the AXEL multi-shell program is run, help messages are displayed (tcpmsh version, maximum number of views, etc)

The program creates only the first view (view 1). A pseudo-terminal is automatically associated with this view.

This view is a copy, of the shell within which the tcpmsh program was run, and the **.profile** script is executed for this view.

To create a new view or to move to an existing view, use `<Ctrl><Fx>`.

If a view does not already exist, the tcpmsh program allocates a pseudo-terminal, launches the view and runs **.profile**.

To delete a view, move to it (`<Ctrl><Fx>`) and exit the shell (by typing **exit** or pressing `<Ctrl><D>`). The tcpmsh software releases the associated pseudo-terminal and moves to the first view.

If the deleted view was the only active view, the program terminates.

## 8.2 - GRAPHICAL MODE SESSION (VNC)

The VNC protocol enables a remote graphical display on the Axel-VNCviewer. The image is constructed, maintained and updated within the Unix server's frame buffer, and transmitted across the TCP/IP network.

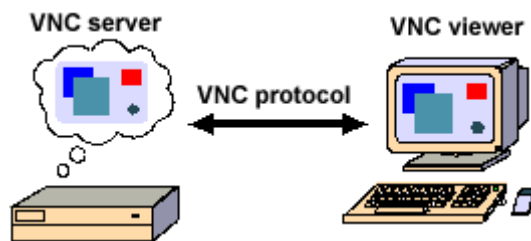

**Note:** this protocol is public and the associated software is free. For more information please see <http://www.realvnc.com/>

The following is a summary of the VNC terminal declaration. For more information, please consult "*AxGVNC - Configuring VNC Terminals under Linux*"

### 8.2.1 - Setting-Up a VNC Session

To set-up a VNC session, select **[Configuration]-[Sessions]-[Session X]** (where X is the session number). The following dialog box is displayed:

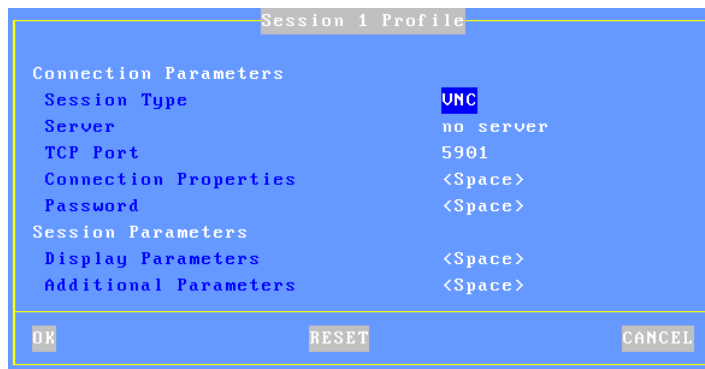

Set the following parameters:

- **Session Type:** select 'VNC'
- **Server:** the server name on which the Xvnc daemon is run
- **TCP Port:** numeric value associated with the display (see Chapter 8.2.2).
- **Connection Properties:** pressing <Space> displays a dialog box which lets certain connection parameters be changed. See sub-section a.
- **Password:** this allows the optional VNC connection password to be stored (Note: this is the VNC password - not the user password).
- **Display Parameters:** pressing <Space> allows display settings (resolution and number of colors) to be set. See sub-section b.
- **Additional Parameters:** pressing <Space> displays a dialog box which lets certain VNC parameters be changed. See sub-section c.

**Note:** after exiting set-up, we advise power-cycling the terminal

#### a) Connection Properties

Within the 'Session Profile' box, select 'Connection Properties' and press <Space>. The following box is displayed:

| Connection Properties |         |
|-----------------------|---------|
| Auto-Connection       | No      |
| Auto-Reconnection     | No      |
| Session Label         | 1 VNC   |
| Enhanced Parameters   | <Space> |
| VALID CANCEL          |         |

These parameters are:

- **Auto-Connection:** if this parameter is set to 'yes', the connection will be automatically established when the AX3000 is powered. Otherwise, the user can press <Alt><Fx> to establish the connection.
- **Auto-Reconnection:** if this parameter is set to 'yes', a new connection is automatically established after a disconnection. Otherwise, the user can press <Alt><Fx> to establish a new connection.
- **Session Label:** this character string (11 characters max.) is used to identify the session within the session manager or in the status line.
- **Enhanced parameters:** see Appendix A.10.3.



### b) Display Parameters

Within the 'Session Profile' box, select 'Display Parameters' and press <Space>. The following box is displayed:

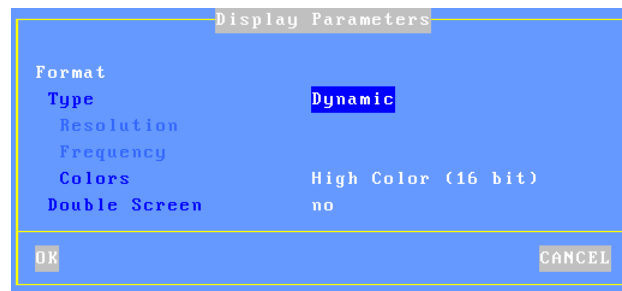

This box allows display settings (resolution, number of colors and frequency) to be set. The availability of these parameters depends of the **Type** value:

- **Dynamic:** The Resolution is given by the Xvnc server when the session is established. If supported, it's accepted by the terminal. Else default value (from general level) is used.
- **Default:** the three parameters (resolution, colors and frequency) are issued from general settings (see Chapter 3.2.2). When general settings are modified, these three parameters are automatically updated with new values.
- **Customized:** the three parameters are independent from general settings.

Two VNC terminals may be used to support a double-width display. The "Double Screen" parameter allows the mode of each terminal to be set:

- **No:** no double screen support
- **Left Part:** this terminal displays the left side of the large virtual screen. The 'Shared Session' option is forced to 'Yes'. See next sub-section.
- **Right Part:** this terminal displays the right side of the large virtual screen. The 'Shared Session' and 'Keyboard and Mouse Ignored' options are forced to 'Yes'. See next sub-section.

### c) Additional Parameters

Within the 'Session Profile' box, select 'Additional Parameters' and press

<Space>. The following box is displayed:



These parameters are:

- **Preferred Encoding:** the 'encoding' is the data format used by the VNC server to send graphical data to the terminal. Supported encodings are:
  - Hextile: original encoding supported by all VNC server versions.
  - ZRLE: newer and higher performing encoding but is only supported by a RealVNC server V4. In addition, ZRLE graphical data may be compressed.
- **Hextile Cache:** when this parameter is disabled, display updates are directly done on the screen itself. Else a display update is first built in memory and then displayed. The global performance is the same whatever the method. But the terminal is more comfortable to be used when the 'Cache Hextile' is enabled.
- **Shared Session:** this allows multiple VNC terminals to share the same graphical display (i.e. the same server frame buffer).
- **Keyboard and Mouse Ignored:** if 'yes' all parameters related to mouse and keyboard are disabled. The terminal no longer sends mouse/keyboard event to the VNC server.

- **<Ctrl><Alt><Del>**: there are two modes for this keystroke:
  - Local: the keystroke is handled by the AX3000 and is used to shutdown the terminal (see Chapter 4.5)
  - Remote: the keystroke is handled by the VNC server.
- **CAPS Key Mode**: set the CAPS LOCK to behave in either of three ways:
  - Caps Lock: each alphabetical key sends the corresponding upper case letter. To unlock this mode press the <CAPS> key.
  - Shift Lock: each key send the same character sent by pressing <Shift><This key>. To unlock this mode press a <Shift> key.
  - Uppercase: each key send the upper character if it is present. Otherwise, this is the lower character (upper-case letter if possible) which is sent. <Shift> key acts in the standard way (whatever the CAPS key). To unlock this mode press the <CAPS> key.
  - Caps Lock +: same as 'Shift Lock'. But in addition ALL the keys supported (including <Esc>, function keys...).
- **Numpad Mode**: this parameter sets the type of keyboard event sent when pressing a key of the numpad:
  - Standard: keyboard events are thus defined by the RFB protocol.
  - ASCII: keyboard events are the same than the top row keys (above QWERTY). With this mode an application can't distinguish if the pressed key belong or not to the numpad. This mode may be required for some JAVE-based applications.
- **(numpad)**: the two available values are the dot (.) and the comma (,).
- **<Scroll Lock> & <Pause>**: enable or disable these two keys
- **<Alt Gr> Mode**: this parameter sets the type of keyboard event sent when pressing <Alt Gr> (located at the right of the space bar):
  - Standard: the keyboard event is AltGr.
  - Ctrl+Alt: the keyboard events are <Ctrl> and <Alt> (left of the space bar).
- **Local Mouse Cursor**: if 'no', the mouse cursor is fully handled by the VNC server. If 'yes', the behavior depends on the VNC server version:
  - Xvnc V3: as above the mouse cursor is handled by Xvnc. In addition the local mouse cursor location is indicated by a little square pointer (2x2 pixels). This can be useful when the local mouse cursor location is different from the VNC cursor location (for example when the Unix/Linux server or the network is overloaded).
  - Xvnc V4: the mouse cursor is handled by the AX3000. With a low-bandwidth, this allows the mouse cursor to be more reactive.

- **Emulate a 3-button Mouse:** if 'yes', the mouse middle button is emulated by clicking both left and right buttons.
- **Mouse Sensitivity:** This setting varies the sample rate of the mouse. If the sensitivity is increased the mouse movement will be more fluid, but also network activity is increased.

### **8.2.2 - Configuring VNC on the Unix/Linux Server**

Axel provides software for configuring VNC terminals under Linux: **AxGVNC**.

AxGVNC checks the Linux configuration and allows, if needed, some system modifications to be automatically done.

#### ***a) Installing AxGVNC***

Use 'gzip' and 'tar' command to extract files from AxGVNC.tar.gz.

Copy the AxGVNC binary file and the languages files (\*.lng) in your preferred folder.

#### ***b) Analyzing Linux***

After being launched AxGVNC automatically checks the Linux settings and allows (or not) VNC terminals to be configured:

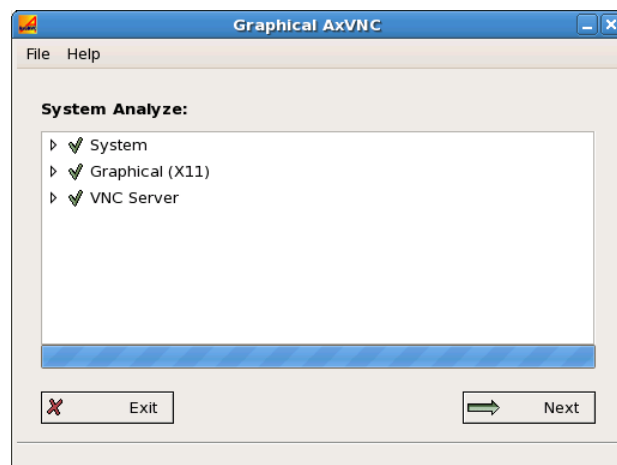

Problems are indicated by red indicators and an attempt to rectify is made by double clicking.

When all indicators are green, click the **[Next]** button.

### c) Configuring VNC Terminals

The following dialog box is displayed:

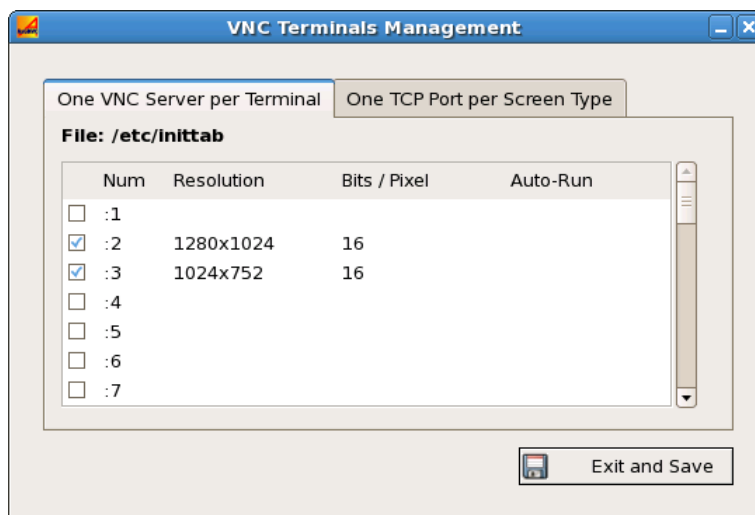

Two methods are available:

- **One VNC Server per Terminal:** when Linux is started, one Xvnc daemon per terminal is run. Each terminal will establish a connection to 'its' Xvnc daemon (identified by a different TCP port).

The main benefit is after an incident (network or other), the terminal will retrieve the lost session.

In addition with this method, the logon screen may be skipped and replaced by any application (Firefox for example).

- **One TCP Port per Screen Type:** an Xvnc daemon is run only when a VNC terminal opens a connection. The TCP port depends on both the resolution and the number of colors.

This mechanism is similar to telnet or SSH: all terminals can use the same TCP port but in event of problem the lost session can't be retrieved.

The benefit is saving resources: the number of running Xvnc daemons is the number of terminals currently in use.

**Note:** the two methods may be hosted on the same Linux server.

Click the tab corresponding to the preferred method and add VNC terminals. (The Linux server will be rebooted for modifications take effect)

### 8.3 - CONTROLLING PRINTERS

Auxiliary ports (2 serial and 1 parallel), logical USB ports and network printer ports are provided by the AX3000. These ports are independently controlled so multiple printers can be attached to the AX3000.

A printer is generally controlled by a network service:

- **tty protocol:** this is an Axel proprietary protocol. A printer controlled by the tty protocol is seen as a local printer.
- **LPD protocol:** this service (RFCs 1048 and related) is provided as a standard feature by major operating systems (Unix/Linux, Windows, etc.). The main benefit of this protocol is an LPD printer can be shared by different operating systems.
- **rsh command:** this command allows the contents of a file to be redirected over the network.

In addition, a printer can also be controlled in "transparent mode" (by embedded escape sequences, like a printer attached to a serial terminal).

The following covers the tty protocol, the rsh command and the transparent mode. For more information about LPD printers, refer to Appendix A.3.

#### **8.3.1 - The tty Protocol**

The tty server is an Axel proprietary protocol. An additional piece of software is needed (see Chapter 8.4).

The Unix/Linux host must run the AXEL tty server daemon (`axttyd`). The configuration file `axttyd` must contain a list of AX3000 auxiliary ports and the ptys associated with each.

Each auxiliary port using the tty protocol (see Chapter 3.5.4) is identified by the name of the AX3000 (from the `/etc/hosts` file) and a special keyword. For example:

|                    |                       |                          |                          |
|--------------------|-----------------------|--------------------------|--------------------------|
| <code>axel1</code> | <code>aux1</code>     | <code>/dev/ptyp12</code> | <code>/dev/ttyp12</code> |
| <code>axel1</code> | <code>aux2</code>     | <code>/dev/ptyp13</code> | <code>/dev/ttyp13</code> |
| <code>axel2</code> | <code>parallel</code> | <code>/dev/ptyp2</code>  | <code>/dev/ttyp2</code>  |

An auxiliary port controlled by the tty server is seen as a Unix/Linux local port (like a multi I/O board).

Data can be sent to an auxiliary port by:

- Either a redirection to the ttyp (example: "cat file > /dev/ttyp12")
- Or declaring a local printer attached to the ttyp (/dev/ttyp12). This printer is used through the `lp` command.

### **8.3.2 - The LPD Protocol**

Set the auxiliary port as shown in Chapter 3.5.2.

Use the appropriate UNIX system management tool to add a remote printer. At least, two parameters are requested:

- The name of the remote host: enter the AX3000's hostname (refer to **`/etc/hosts`**),
- The name of the printer: this is the **Printer Port Name** entered when the AX3000 was set up.

Run the `lp` command to use this printer.

**Note:** some options of the `lp` command (number of copies, banner, etc) cannot be used, because the AX3000 is not a UNIX server and has no hard disk on which to run a spooler.

**a) Using lpd under IBM AIX V3.x**

Enter the SMIT fast path **smit mkrque**. Four parameters are required:

- **Name of Queue to Add:**  
⇒ name of the printer accessed by the **lp** command
- **Destination Host for Remote Jobs:**  
⇒ hostname of the AX3000 (refer to **/etc/hosts**)
- **Name of Queue on Remote Printer:**  
⇒ '**Printer Port Name**' associated with the AX3000's port
- **Name of Device to Add:**  
⇒ device name of printer on AIX

**b) Using lpd under IBM AIX V4.x**

Enter the SMIT fast path **smit spooler** then select '**Add a Print Queue**' and '**Remote**'.

Printers can be added using either of two methods:

- **Standard Processing:** AIX sends a raw file to the AX3000. Three parameters are required:
  - **Name of Queue to Add:** name of the printer accessed by the **lp** command
  - **Destination Host for Remote Jobs:** hostname of the AX3000 (refer to **/etc/hosts**)
  - **Name of Queue on Remote Printer:** this is the '**Printer Port Name**' associated with the AX3000's port
- **Local Filter:** AIX passes the file to the printer through a formatting filter. The first parameter required is the type of printer. Select this from the list of supported printers. Three parameters are required:
  - **Name of Queue to Add:** name of the printer accessed by the **lp** command
  - **Destination Host for Remote Jobs:** hostname of the AX3000 (refer to **/etc/hosts**)
  - **Name of Queue on Remote Printer:** this is the '**Printer Port Name**' associated with the AX3000's port

**Note:** Use of the Local Filter method is strongly recommended.



### ***c) Using lpd under SCO UNIX***

Run **scoadmin** and select **[Printer]-[Printer Manager]**. Then select **[Printer]-[Add Remote...]-[UNIX]**. A dialog box is displayed. Two parameters are required:

- **Host:** hostname of the AX3000 (refer to `/etc/hosts`)
- **Printer:** this is the '**Printer Port Name**' associated with the AX3000's port

**Note:** an AX3000 filter may be needed.

### **8.3.3 - The rsh Command**

The rsh command (or rcmd on SCO OpenServer) can be used to print a file.

The rsh parameters are:

- The hostname or the IP address of the device,
- A keyword which is the AX3000 auxiliary port name. This name has been set through the AX3000 Set-Up (see Chapter 3.5.6).

To print a file, the rsh command reads data from 'standard input' (`stdin`) and sends this data to one of the AX3000's auxiliary ports. For example:

```
$ rsh axname parallel < file <CR>
```

In this example, `axname` is the name of the AX3000 (refer to `/etc/hosts` file) and `parallel` is the Printer Port Name of the AX3000 auxiliary port.

### **8.3.4 - Using Transparent Mode**

One of the auxiliary or logical ports should be selected as the default printer port which will be controlled by escape sequences.

Select the **[Configuration]-[Terminal]-[Miscellaneous]** dialog and set the 'default printer port'.

This default port can only be used if no network service (`lpd`, `tty`, etc) is currently using it.

**Note:** the default printer port is also used to perform local printing of the screen using the <Prt Scr> key.

## 8.4 - THE AXEL TTY SERVER

### 8.4.1 - Overview

The TTY server emulates a multi i/o board connection over a TCP/IP connection. For example using this service a remote printer attached to an Axel terminal is accessed by Unix as a local printer via /dev/tty4, which may be preferable over using LPD in certain circumstances. Similarly the Axel terminal can be accessed via a predetermined and fixed /dev/tty, which in certain cases may be preferable over using telnet.

The AXEL tty server is a UNIX daemon (axttyd). The axttyd daemon must be used with the AX3000 **tty** or **rtty** network service.

The AXEL tty server creates a 'pipe' between pseudo devices on the UNIX host (/dev/ttyxx) and AX3000 resources (sessions and/or auxiliary ports). This 'pipe' lets Unix treat the Axel sessions and auxiliary ports as local resources.

**Note about pseudo-terminals:** a pseudo-terminal is composed of two parts: a master file and a slave file. UNIX supports two possible styles for naming pttys:

- One master and X slaves (AT&T style): the master filename is **/dev/ptmx** and the slave filenames are **/dev/pts/xxx** (where **xxx** is a number).
- X masters and X slaves (Berkeley style): the master filename is **/dev/ptypxxx** and the slave filenames are **/dev/ttypxxx** (where **xxx** is the same number for master and slave).

The following drawing shows the Unix/Linux mechanisms:

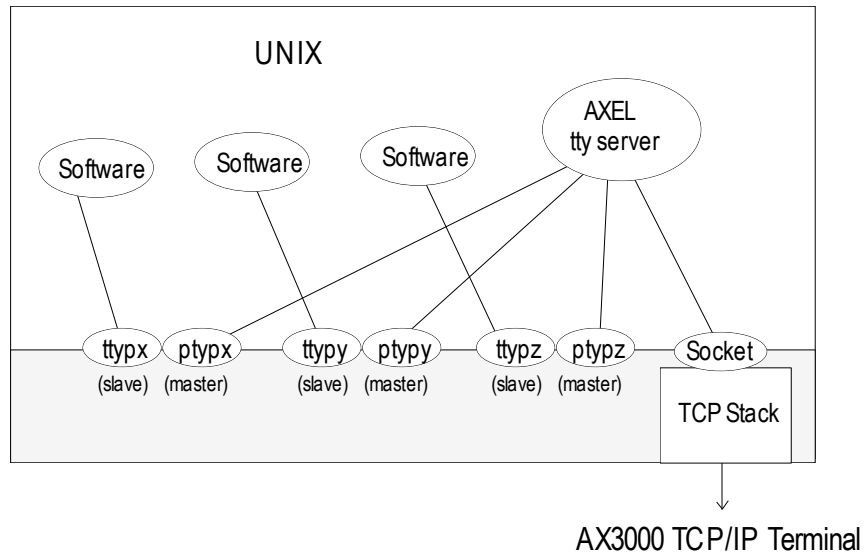

### 8.4.2 - Installing an AXEL tty server

Copy to **/etc** and rename as **axttyd** the appropriate binary. Example for IBM AIX:

```
# cp axttyd.AIX /etc/axttyd <CR>
```

**Note:** the source file and the **makefile** are also provided. If the binary file required for your operating system is not provided, it can be generated.

Copy the AXEL association file (**axfile**) into the **/etc** directory:

To launch the AXEL tty server automatically, whenever the host is booted, copy into the boot directory the **S91axel** file (for Unix) or the **S91axtty** file (for Linux).

The **S91axel** or **S91axtty** files launch the AXEL tty server. If parameters other than the default are required, this command line can be edited.

### 8.4.3 - Using an AXEL tty server

#### a) Overview

The AXEL tty server uses a configuration file which lists all authorized associations between AX3000 resources and UNIX ptty. Each entry in this file contains four parameters:

- AX3000 hostname (see **/etc/hosts**)
- The AX3000 resource, which depends on which network service is used:
  - tty on terminal session: **sess1, sess2, ..., sess6**
  - tty on auxiliary port: **aux1, aux2** and **parallel**,
  - tty on logical USB port: **usb1, usb2, usb3** and **usb4**,
  - tty on logical TCP port: **net1** and **net2**,
  - rtty: encoded by a TCP port
- The master file of the pty (**/dev/pty** or **/dev/ptmx**)
- The slave file of the pty (**/dev/ttyp**, **/dev/pts/xxx** or a link file automatically created by **axttyd**).

For example:

| #AX3000 | Resource | Master      | Slave       |
|---------|----------|-------------|-------------|
| axe11   | aux1     | /dev/ptyp12 | /dev/ttyp12 |
| axe11   | aux2     | /dev/ptmx   | /dev/pts/13 |
| axe12   | 2050     | /dev/ptyp0  | /dev/ttyp0  |
| axe12   | sess1    | /dev/ptmx   | /dev/axe1   |
| axe12   | sess2    | /dev/ptyp2  | /dev/ttyp2  |

#### Notes:

- Lines beginning with '#' are ignored.
- Association lines 1, 2, 4 and 5 use the tty service, and association line 3 uses rtty service.
- Association line 4 uses a link file (**/dev/axe1**). This file is linked with an undefined slave ttyp (**/dev/pts/xxx**). This link file is automatically created when **axttyd** is run.

Errors (syntax error, unknown AX3000 hostname, pty not available, etc) are recorded in a log file.

### **b) Running the Axel Tty Server**

The command to start the AXEL tty server is:

```
/etc/axttyd [-f file] [-l log] [-n port] [-hbFUk] &
```

- b: use a buffer for received data.
- f: configuration file (default: /etc/axfile).
- F: tty buffers are flushed when the tty connection is established.
- h: on-line help.
- l: log file (default: /tmp/axttylog).
- n: TCP port (default: 2048) for connections using the tty service.
- U: only unidirectional dataflow is supported. Data from the network is dropped.
- k: turn-off keepalive function.

**Note:** take care to add the '&' character at the end of line.

The AXEL tty server can be started either from the UNIX command line or at boot time (from **S91axel** or **S91axtty**).

All authorized associations, connections and disconnections will be recorded in the specified log file.

#### **8.4.4 - The axttyd Mechanism**

The axttyd daemon performs the following steps:

- **init stage:** association file checking (errors are reported in the log file) and associated pty opening (masters and slaves),
- **rtty stage:** for each rtty association, a child process is created. Each child process listens on the associated pty. When data is received a socket is opened on the AX3000 auxiliary port. Bi-directional communication is then enabled. If no data is sent or received for any one minute interval, the connection is closed. It will be opened again, the next time data is received from the pty.
- **tty stage:** when all the rtty child processes are created, the axttyd daemon listens on the TCP/IP socket (generally 2048). For each connection request (from an AX3000 tty service), a child process is created. This process controls communication between the pty and the AX3000 resource (session or auxiliary port).

### **8.4.5 - Uninstalling**

Remove the AXEL files and kill the AXEL tty server process (signal TERM):

```
# kill -TERM pid<CR>
```

where `pid` is the process ID of the AXEL tty server.

### **8.4.6 - In Event of Problems...**

In event of difficulties please consult the logfile (`/tmp/axttylog`) and to read the last messages.

#### ***a) Message "Can not bind TCP port"***

The message indicates the axtty TCP port (2048 by default) is currently in use. This port must be released.

#### ***b) Message "Waiting for connections from TCP/IP socket"***

Initialization is correct and completed. The Axel tty server is now waiting for incoming connections. Check terminal settings (specially the tty auto-connection parameter). Possibly a firewall is blocking communication from the terminal to the server.

## **8.5 - REMOTE ADMINISTRATION**

### **8.5.1 - Remote Control**

This functionality allows an administrator to remotely take control of a terminal. The administrator can passively watch the users screen or actively take control with his own keyboard for various support or administration purposes.

For more information refer to Chapter 10.2.

### **8.5.2 - Other Functions**

☺: Axel's Windows administration utility (AxRM or Axel Remote Management) is

available free on the Axel Web site. See Chapter 10.1.

The following rsh commands allow an AX3000 to be controlled over the network. (On SCO OpenServer the rsh command is called rcmd).

### **a) Rebooting the AX3000**

To reboot an AX3000 over the network, invoke the following command:

```
# rsh axname ax_reboot password
```

Where:

- axname : AX3000 name (/etc/hosts) or IP address,
- ax\_reboot : command for AX3000 reboot,
- password : specify the set-up password if set.

### **b) Resetting an AX3000 Resource (screen session or aux. port)**

The reset feature allows:

- A network service to be stopped and restarted
- To apply new serial line settings (data transfer rate, handshake, etc.).

The supported resources are:

- Screen sessions: sess1, sess2....
- Auxiliary ports: aux1, aux2, parallel, netX and usbX.

Use the following command to reset a resource:

```
# rsh axname ax_sinit password ress
```

Where:

- axname : AX3000 name (/etc/hosts) or IP address,
- ax\_sinit : command to reset the resource,
- password : specify the set-up password if set,
- ress : resource name (ex: sess1).

### **c) Editing the AX3000 Settings**

The whole AX3000 set-up can be obtained by invoking the following command:

```
# rsh axname setup_get > /tmp/axel
```

or a partial set-up can also be obtained (only used set-up parameters are sent):

```
# rsh axname setup_get_lite > /tmp/axel
```

Where:

- axname : AX3000 name (/etc/hosts) or IP address,
- setup\_get : command for getting the whole set-up,
- setup\_get\_lite : command for getting the partial set-up.

For more information about these commands, refer to Chapter 10.

#### **d) Setting-Up the AX3000**

The contents of a file is used to set-up the AX3000:

```
# rsh axname setup_send password < /tmp/axel
```

Where:

- axname : AX3000 name (/etc/hosts) or IP address,
- setup\_send : command for set-up the AX3000,
- password : specify the set-up password if set.

For more information about this command, refer to Chapter 10.

#### **e) Downloading Firmware**

To download an AX3000 firmware through TFTP:

```
# rsh axname ax_download password /axfirm/axel 192.168.1.2 192.168.1.1
```

To download an AX3000 firmware through BOOTP and TFTP:

```
# rsh axname ax_download password
```

Where:

- axname : AX3000 name (/etc/hosts) or IP address,
- ax\_download : command for firmware downloading,
- password : specify the set-up password if set.
- /axfirm/axel : path and name of the firmware file,
- 192.168.1.2 : TFTP Server IP address,
- 192.168.1.1 : optional router IP address.



Messages are displayed on the target AX3000 (See Chapter 11.4).

**f) Viewing AX3000 Statistics**

Some AX3000 statistics can be obtained by invoking the following command:

```
# rsh axname ax_getstat
```

Where:

- axname : AX3000 name (/etc/hosts) or IP address,
- ax\_getstat : command for getting statistics.



**- 9 -**

**TOOLS AND STATISTICS**

*This chapter describes the embedded AX3000 tools.*

The AX3000 interactive set-up provides the following administration features:

- Ping command
- Connection management
- Interface information
- USB device list

## **9.1 - THE PING COMMAND**

The ping command is used to check for the presence of a live TPC/IP device. Select the **[Diagnostics]-[Ping]** dialog from the AX3000 set-up, then enter the IP address or the name of the TCP/IP peripheral.

## **9.2 - CONNECTION MANAGEMENT**

Connection failures are often caused by incorrect settings.

### 9.2.1 - Global Connection List.

Select the **[Diagnostics]-[Connections]** dialog to check the status of all defined connections:

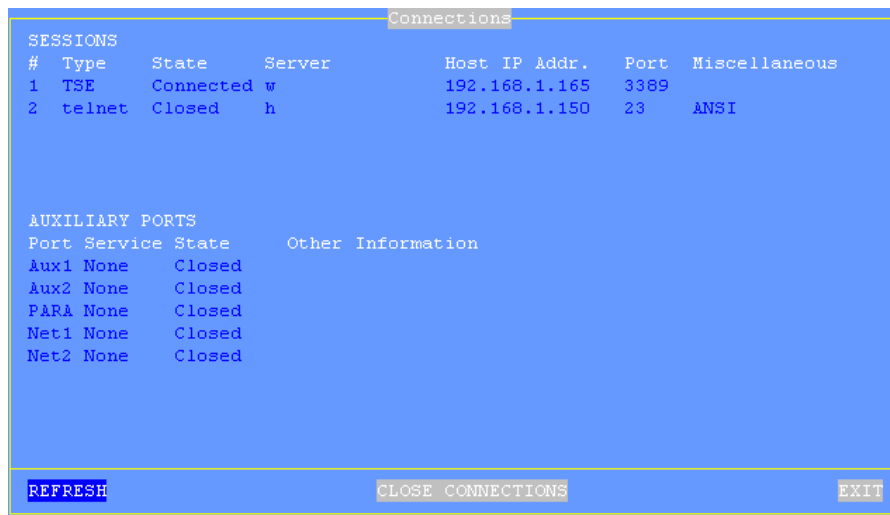

The screenshot shows a terminal window titled 'Connections'. It displays two sections: 'SESSIONS' and 'AUXILIARY PORTS'. The 'SESSIONS' section is a table with columns for session number, type, state, server, host IP address, port, and miscellaneous information. The 'AUXILIARY PORTS' section is a table with columns for port name, service, state, and other information. At the bottom of the window are three buttons: 'REFRESH', 'CLOSE CONNECTIONS', and 'EXIT'.

| SESSIONS |        |           |        |               |      |               |
|----------|--------|-----------|--------|---------------|------|---------------|
| #        | Type   | State     | Server | Host IP Addr. | Port | Miscellaneous |
| 1        | TSE    | Connected | w      | 192.168.1.165 | 3389 |               |
| 2        | telnet | Closed    | h      | 192.168.1.150 | 23   | ANSI          |

| AUXILIARY PORTS |         |        |                   |
|-----------------|---------|--------|-------------------|
| Port            | Service | State  | Other Information |
| Aux1            | None    | Closed |                   |
| Aux2            | None    | Closed |                   |
| PARA            | None    | Closed |                   |
| Net1            | None    | Closed |                   |
| Net2            | None    | Closed |                   |

**Note:** 'outside' the set-up, use <Ctrl><Alt><X> displays this box.

For each session, the following information is displayed:

- **No:** session number.
- **Type:** main values are TSE, ica, telnet, tty, vnc...
- **State:** the possible values are:
  - Established: the session is connected,
  - Closed: the session has ended,
  - Syn sent: connection request in progress,
  - Time Wait: connection close in progress.
- **Server** and **IP Addr Host:** the associated host.
- **Port:** the TCP port used for the session (this is usually 23 for telnet, 2048 for tty and 59xx for vnc).
- **Configuration:** the associated pre-defined configuration.

For each auxiliary port, the following information is displayed:

- **Port**: the name of the port: Aux1, Aux2, PARA (parallel), Usb1, ..., Usb4, Net1 and Net2
- **Service** and **Other**: information about the associated network service:
  - lpd: printer port name and optional filter,
  - rcmd: printer port name,
  - telnet: associated host, TCP port, TERM and connection flags,
  - tty: associated host, TCP port and connection flag,
  - prt5250: associated host, TCP port, printer name and AS/400 connection status,
  - printd or rtty: TCP port and optional filter.
- **State**: see above for the possible values.

A connection can be manually closed by selecting the [CLOSE CONNECTION] button.

**Note**: to refresh the information displayed, select the [REFRESH] button.

### **9.2.2 - "TCP Server" and "TCP Client" Connection Information**

To go further with connection information, two additional statistics dialog boxes are available:

- **TCP server**: contains information about connections where the AX3000 is acting as a server (lpd, rtty and rcmd).
- **TCP client**: contains information about connections where the AX3000 is acting as a client (telnet, tty, rdp, ica and vnc).

These statistics show the following:

- Information about connections
- Values of counters

These dialog boxes are accessed by the [Diagnostics]-[Statistics]-[TCP xxx]-[yyy] menu.

Example of a Connection box:

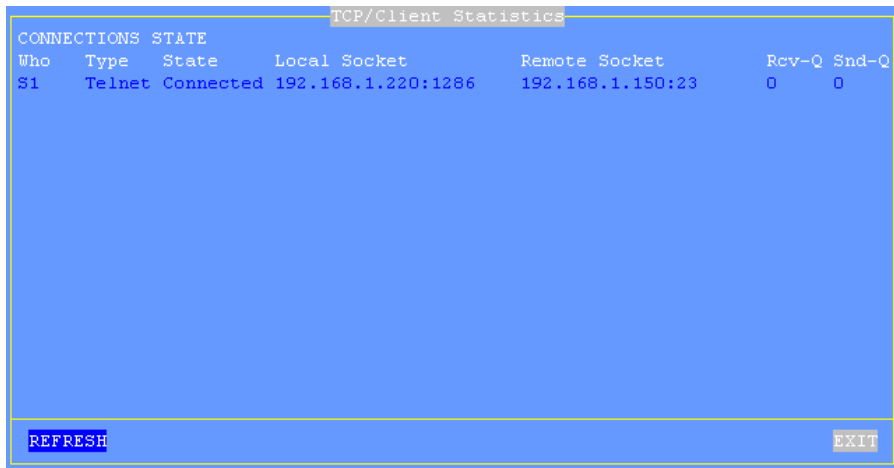

The screenshot shows a window titled "TCP/Client Statistics" with a blue background. At the top, it says "CONNECTIONS STATE". Below this is a table with the following columns: Who, Type, State, Local Socket, Remote Socket, Rcv-Q, and Snd-Q. There is one row of data: S1, Telnet, Connected, 192.168.1.220:1286, 192.168.1.150:23, 0, and 0. At the bottom left of the window is a "REFRESH" button and at the bottom right is an "EXIT" button.

| Who | Type   | State     | Local Socket       | Remote Socket    | Rcv-Q | Snd-Q |
|-----|--------|-----------|--------------------|------------------|-------|-------|
| S1  | Telnet | Connected | 192.168.1.220:1286 | 192.168.1.150:23 | 0     | 0     |

Description of the information given within this box:

- **Who:** AX3000 resource involved in the connection: S1 (session 1), ..., S8 (session 8), Aux1, Aux2, PARA (parallel), Usb1, ..., Usb4, Net1 and Net2.
- **Type:** network service being used (telnet, tty, etc).
- **State:** the possible values are:
  - Established: the session is connected,
  - Closed: the session has ended,
  - Syn sent: connection request in progress,
  - Time Wait: connection close in progress.
- **Local Socket:** IP address and TCP port for the AX3000.
- **Remote Socket:** IP address and TCP port for the host.
- **Rcv-Q:** number of bytes received by the AX3000 and not yet processed
- **Snd-Q:** number of bytes not yet sent to the host

Example of a Counter box:

| TCP/Client Statistics    |   |            |   |
|--------------------------|---|------------|---|
| GENERAL                  |   | ERRORS     |   |
| Sent Connection Requests | 1 | Bad CRC    | 0 |
| Sent Reset Frames        | 1 | Bad Length | 0 |
| Received Broadcasts      | 0 |            |   |
| REFRESH                  |   | EXIT       |   |

## 9.3 - ETHERNET INTERFACE INFORMATION

### 9.3.1 - Status

Checking the interface status could be needed when using DHCP and/or DNS, The following information is displayed when selecting the **[Configuration]-[Network]-[Ethernet Interface]-[Status]** menu:

| Ethernet Interface |                  |
|--------------------|------------------|
| Connection         |                  |
| State              | Connected        |
| Link               | 100BT HalfDuplex |
| IP Parameters      |                  |
| IP Address         | 192.168.1.234    |
| Netmask            | 255.255.255.0    |
| Default Router     | -                |
| Other Information  |                  |
| FQDN               | axe1000013       |
| DHCP and DNS       | <Space>          |
| Statistics         | <Space>          |
| REFRESH            |                  |
| EXIT               |                  |

**Note:** this box information is automatically updated every 5 seconds. To force an update use the [REFRESH] button.



In the above dialog box, the following information is given:

- **Link:** speed and type the network interface (useful when set in auto-sense mode).
- **IP parameters:** IP address, netmask and default router
- **FQDN:** terminal full name

### 9.3.2 - DHCP/DNS

The DHCP/DNS box is the following:

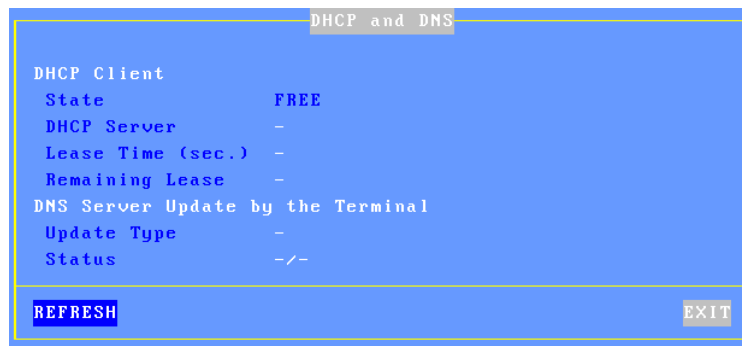

In the above dialog box, the following information is given:

- **State:** the current DHCP state. The possible states are:
  - **selecting:** searching a DHCP server (broadcast)
  - **requesting:** requesting an IP address from the DHCP server which answered 'selecting'
  - **bound:** search has been successfully completed (IP address has been set)
  - **free:** DHCP protocol is not enabled or DHCP protocol failed
  - **renewing:** renewing the leased IP address to the DHCP server which answered 'selecting'
  - **rebinding:** renewing the leased IP address to any DHCP server (broadcast)
- **DHCP Server:** IP address of the DHCP server.
- **Lease Time (seconds):** amount of time of the leased IP address. For BOOTP protocol, the value is 'infinity'.
- **Remaining Lease:** remaining time before lease expires. For BOOTP protocol, the value is 'infinity'.

- **Update Type:** information about the DNS server update when updated by the terminal. Main values are:
  - **None:** no update
  - **Direct / Reverse:** both types are done by the terminal.
  - **Direct / Reverse (by DHCP):** direct update done by the terminal and reverse update done by the DHCP server
- **Status:** the possible update values are:
  - **None:** no update (not requested)
  - **Done:** update succeeded
  - **Failed:** update failed
  - **Pending:** update in progress
  - **Dhcp:** update done by the DHCP server (the terminal had been informed to forgive the update)

### 9.3.3 - Statistic

The statistics box is the following:

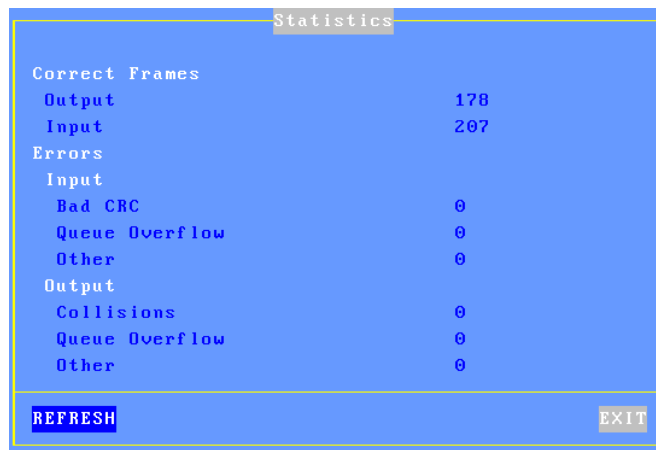

The screenshot shows a window titled "Statistics" with a blue background. It displays network statistics in a text-based format. The data is as follows:

| Correct Frames |     |
|----------------|-----|
| Output         | 178 |
| Input          | 207 |
| Errors         |     |
| Input          |     |
| Bad CRC        | 0   |
| Queue Overflow | 0   |
| Other          | 0   |
| Output         |     |
| Collisions     | 0   |
| Queue Overflow | 0   |
| Other          | 0   |

At the bottom of the window, there are two buttons: "REFRESH" on the left and "EXIT" on the right.

**Correct Frames:** "Output" and "Input" are the number of correct frames (transmitted and received)

**Errors:** this section gives the type and the number of errors. No errors should be shown in a good working environment/healthy network.

## 9.4 - USB STATISTICS

The **[Diagnostics]-[USB]** menu lists the connected USB devices. For example

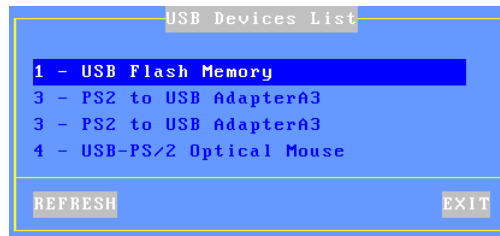

For each line the number is the USB physical port number. The associated label is given by the USB product itself.

If the USB product is supported, more information can be obtained by pressing <Enter>. If a beep is sounded the product is not supported.



**- 10 -  
REMOTE ADMINISTRATION**

*This chapter covers remote administration of the TCP/IP AX3000.*

Four types of operations are provided by the remote administration:

- The use of AxRM,
- The remote control,
- The interactive telnet setup,
- The batch set-up (getting and sending a set-up file)

## 10.1 - AXRM: THE AXEL MANAGEMENT SOFTWARE

A Windows administration utility (AxRM or Axel Remote Management) is available at no charge from the Axel Web site (<http://www.axel.com>):

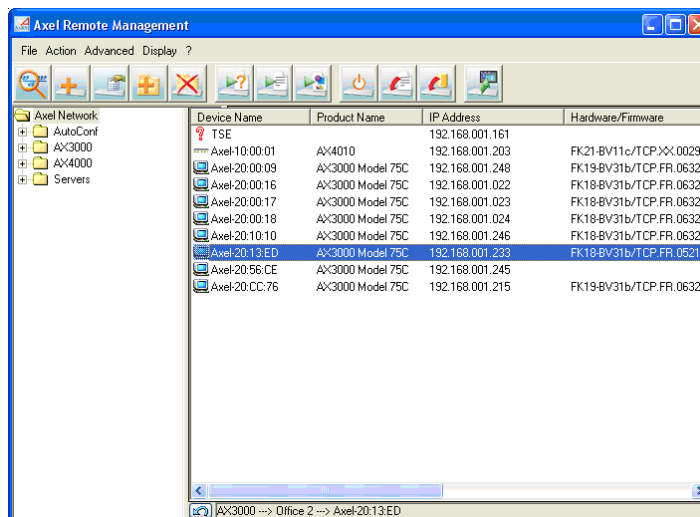

The AxRM software allows system administrators to manage and configure Axel TCP/IP products remotely over a network. The remote Axel device is selected by its IP address or network name. (The software can also assign an IP address to a newly installed terminal that has not had an IP address set)

AxRM is an abbreviation for Axel Remote Management software.

AxRM is used for:

- Obtaining hardware and firmware revision levels
- Obtaining Ethernet and serial line configuration
- Obtaining network and device statistics
- Obtaining set-up configuration
- Rebooting the peripheral
- Remotely configuring a peripheral
- Downloading firmware,
- Entering the interactive set-up via a telnet client.

It is also possible:

- To build and manage a terminal database,
- To compile a list (batch) of commands to run consecutively,
- To download a firmware through BOOTP,
- To set IP addresses by using the device MAC address.
- Repair terminals that have lost their firmware (bootp error)

For more information about the AxRM utility, read the manual "*Axel Remote Management - Administration Software for Axel Terminals and Office Servers*".

## 10.2 - REMOTE CONTROL

This functionality allows an administrator to remotely take control of a terminal. The administrator can passively watch the users screen or actively take control with his own keyboard for various support or administration purposes.

The prerequisite of this function are:

- Only a text-mode display is supported. This is the following session types:  
telnet, 5250, 3270 and set-up environment

- The remote control function is enabled on the remote terminal (see below).

### **10.2.1 - Configuring**

To set-up the remote control function, select the menu **[Configuration]-[Terminal]-[Remote Control]**. For more information, please refer to Chapter 3.2.6.

### **10.2.2 - Operation**

Use AxRM to take the control of the terminal. See Chapter 10.1.

## **10.3 - INTERACTIVE TELNET SET-UP**

The AX3000 interactive set-up can be accessed through a telnet session. A specific TCP port is used.

The default value of this TCP port is 4096. This value can be changed. (See Chapter 3.2.6.)

We strongly advise using AxRM to open the telnet setup (see Chapter 10.1). But any telnet client could be used with the correct arguments as below

- ANSI emulation (with color support)
- TERM value: ansi
- Screen size: 80x25
- Scrolling mode disabled

#### **Notes:**

- To disable the telnet set-up, set the TCP port to 0.
- When the telnet set-up is running, the set-up is also displayed on the target terminal. The keyboard of the target terminal is locked.
- The AX3000 telnet server supports the keepalive mechanism (value 3 minutes). In event of network incident, the set-up will be automatically ended and the keyboard of the target terminal will be unlocked.



The possible connection errors are:

- The interactive set-up is already in use on the target terminal.
- The client telnet arguments as given above are not set.

## 10.4 - BATCH REMOTE SET-UP

This feature enables an AX3000 to be set up remotely, using the remote administration command. A text file (provided as an argument to the remote administration command) defines the value of some or all set-up parameters. It can either be:

- Created with a text editor or
- Obtained by a remote administration command on an AX3000 already set-up.

We strongly advise using AxRM to operate with the batch setup (see Chapter 10.1), but native system commands can be used. Refer to the Chapter 8.5 (Unix/Linux), the Chapter 6.4 (OS/400) or the Chapter 7.3 (OS/390).

The remote administration command parameters are:

- The name or the IP address of the AX3000,
- A command: one of the 3 following keywords:
  - **setup\_send** : set-up an AX3000,
  - **setup\_get** : get an AX3000 configuration,
  - **ax\_reboot** : reset an AX3000.

**Note:** to access an AX3000 with the **rsh** command, the IP address of the AX3000 must already have been set

### 10.4.1 - AX3000 Remote Set-Up

To set-up an AX3000 remotely, use the '**setup\_send**' command. Example for Unix/Linux:

```
# rsh axname setup_send password < conf_file
```

**Notes:**

- The next chapter explains how to create the configuration file **conf\_file**, either using a text editor or using the **'setup\_get'** command on an existing terminal. Appendix A.5 contains a detailed description of the configuration file.
- **password**: specify the password if the set-up is password-protected.

The message 'Store set-up in progress...' is displayed on the operator's console while the remote command is processing. If a connection problem occurs, a time-out error message is displayed.

When the configuration has been successfully completed, the message 'OK, set-up updated' is displayed on the operator's console. If other messages are displayed, refer to Chapter 10.4.3.

The AX3000 must read this new set-up before it will take effect. This can be achieved either by power-cycling the AX3000 or by the following **'ax\_reboot'** command. Example for Unix/Linux:

```
# rsh axname ax_reboot password
```

**Note about password:** specify the password if the set-up is password-protected.

The message 'Reboot in progress...' is then displayed on the operator's console, the AX3000 is reset and the new set-up is implemented. If a connection problem occurs, a time-out error message is displayed.

**10.4.2 - Obtaining a Configuration**

To obtain the configuration from an existing AX3000 terminal, use the **'setup\_get'** command (or **'setup\_get\_lite'** command). This command sends a list of all AX3000 parameters to standard output. Example for Unix/Linux:

```
# rsh axname setup_get > /tmp/file<CR>
```

The message 'Load set-up in progress...' is displayed on the operator's console when the **rsh** command is processing. If a connection problem occurs a time-out error message is displayed.

When the set-up parameters have been loaded, the message 'OK, set-up sent' is displayed on the operator's console. If other messages are displayed, refer to chapter 10.3.3.

The configuration file lists each set-up parameter. Refer to Appendix A.5 for a detailed description of this file.

### **10.4.3 - Error Messages**

There are two types of error:

- Fatal errors: numbered from 100 to 114,
- Warning errors: numbered from 200 to 221.

#### **a) Fatal Errors**

Fatal errors stop the remote command. The following fatal errors may occur:

ERR 101: header label expected.

Command: **setup\_send**  
Cause: the AXEL header label (BEGIN\_AX\_SETUP) is not the first line of the configuration file.  
Consequence: the AX3000 set-up is not modified.  
Solution: check the file. Replace it with a correct configuration file.

ERR 102: bad header label protocol version.

Command: **setup\_send**  
Cause: the protocol version (included in the header label) cannot be processed by the current AX3000 firmware.  
Consequence: the AX3000 set-up is not modified.  
Solution: use a configuration file with a compatible protocol.

ERR 103: trailer label not found. Default factory set-up reloaded

Command: **setup\_send**

Cause: the trailer label (`END_AX_SETUP`) is not found. (Either this label is not included in the configuration file or the connection failed).

Consequence: the default factory set-up is reloaded (to replace the inconsistent configuration caused by the missing trailer label).

Solution: add this label to the end of file and run the command again.

ERR 104: Can not get complete set-up (rcmd command aborted).

Command: **setup\_get**

Cause: a network problem has occurred or the command has been killed or aborted.

Consequence: the set-up obtained by the command is invalid (the trailer label is missing).

Solution: run the command again.

ERR 105: invalid rcmd command.

Command: ---

Cause: the keyword is unknown.

Consequence: no effect.

Solution: use the correct keyword (**setup\_send**, **setup\_get** or **ax\_reboot**).

ERR 106: cmos busy.

Command: **setup\_send**

Cause: another command (**setup\_get** or **setup\_send**) is running, or another user has entered set-up from the target terminals keyboard.

Consequence: no effect.

Solution: Either wait for a few seconds and repeat the command, or arrange for the other user to exit set-up on the target AX3000.

ERR 113: password required

Command: **setup\_send, ax\_reboot and ax\_download**  
Cause: the AX3000 Interactive Set-Up is password-protected. This password hasn't be specified within the command.  
Consequence: no effect.  
Solution: use the right password.

ERR 114: invalid password

Command: **setup\_send, ax\_reboot and ax\_download**  
Cause: the AX3000 Interactive Set-Up is password-protected. This right password hasn't be specified within the command.  
Consequence: no effect.  
Solution: use the right password.

### ***b) Warning Error Messages***

Warning error messages do not stop the command but indicate a problem (such as a syntax error). The following warnings may occur:

ERR 201: xxx: unknown parameter name.

Command: **setup\_send**  
Cause: the set-up parameter (xxx) is unknown.  
(e.g.: s1\_screencolumn instead of s1\_screen\_column).  
Consequence: the set-up parameter is ignored. The current value of this parameter is retained.  
Solution: check the spelling of the set-up parameter (Appendix A.5).

ERR 202: xxx: invalid value.

Command: **setup\_send**  
Cause: the value assigned to this set-up parameter (xxx) is not valid (example: multi\_nbpage=10).  
Consequence: the set-up parameter is ignored. The current value of this parameter is retained.  
Solution: check the possible values of this parameter (Appendix A.5).

ERR 203: xxx: no place to store udk value.

Command: **setup\_send**  
Cause: not enough memory to store the `udk_xxx` parameter (udk stands for User-Defined Key; a function key for example).  
Consequence: the default value of this udk parameter is restored.

ERR 204: line(s) after the trailer label ignored.

Command: **setup\_send**  
Cause: `END_AX_SETUP` is not the last line of the file.  
Consequence: the lines after the trailer label are ignored. The AX3000 set-up is updated.  
Solution: delete these lines.

ERR 211: service name/number error. Service(s) may be reset.

Command: **setup\_send**  
Cause: Other services, such as print or tty, use the same identifier (TCP port or name).  
Consequence: to get a consistent configuration, some services have been removed.  
Solution: check service identifier values.

ERR 212: host error. Host(s) may be reset.

Command: **setup\_send**  
Cause: host parameters are missing or two host names are identical.  
Consequence: to get a consistent configuration, some hosts may have been removed.  
Solution: check the host configuration.

ERR 213: too many sessions or pages. Page number set to 1.

Command: **setup\_send**  
Cause: eight screens are supported by the AX3000. This resource is shared by sessions and pages (i.e. `multi_nbsession * multi_nbpage ≤ max. session`).  
Consequence: to get a consistent configuration, the `multi_nbpage` parameter is set to one.  
Solution: check the number of sessions and pages.

ERR 214: Associate host not found. Association reset.

Command: **setup\_send**  
Cause: a session is associated with a non existing host.  
Consequence: to get a consistent configuration, this session is not associated with a host.  
Solution: check the host configuration.

ERR 215: s%\_udk\_xxx and following: no place to store udk value.

Command: **setup\_send**  
Cause: not enough memory to store a group of programmable keys.  
Consequence: the default values of these keys are restored.

ERR 218: Telnet service and default port conflict.

Command: **setup\_send**  
Cause: the telnet set-up TCP port is in conflict with another service.  
Consequence: the telnet set-up doesn't work properly.  
Solution: the conflict must be fixed.

ERR 219: ASCIItoEBCDIC: only on default port.

Command: **setup\_send**  
Cause: The ASCII to EBCDIC operating mode is not associate with the default port.  
Consequence: the auxiliary port doesn't work properly.  
Solution: change the default auxiliary port.

ERR 221: Service and RDP redirection conflict.

Command: **setup\_send**  
Cause: an auxiliary port is used by both the RDP redirection and by a network service.  
Consequence: the auxiliary port doesn't work properly.  
Solution: the conflict must be fixed.





# APPENDIX

The following appendices give information about:

- A.1 - Using the AX3000 interactive set-up
- A.2 - Network overview (Ethernet address, IP address and routers)
- A.3 - DHCP protocol
- A.4 - DNS protocol
- A.5 - Remote set-up configuration file format
- A.7 - Setting the IP address by a ping command
- A.8 - Administration command list
- A.9 - Firmware downloading
- A.10 - Going further...
- A.11 - Hardware and firmware information

## **A.1 - USING THE INTERACTIVE SET-UP**

### **A.1.1 - Entering the Set-Up**

The following can be used to enter the AX3000 interactive set-up:

- Using <Ctrl><Alt><Esc> from the terminal
- Using the AxRM remote control command. See Chapters 10.1 and 10.2.
- Using Telnet to access the terminal remotely. (See Chapter 10.3.)

**Note:** the set-up can be password-protected, in which case the password must be entered to access the quick set-up dialog box. For more information, see Chapter 3.2.7.

**A.1.2 - Navigation**

The AX3000 set-up comprises a horizontal general menu, with drop down vertical menus.

The mouse cannot be used within the telnet session.

A help line is located in the bottom of the screen.

The AX3000 set-up screen appears as follows:

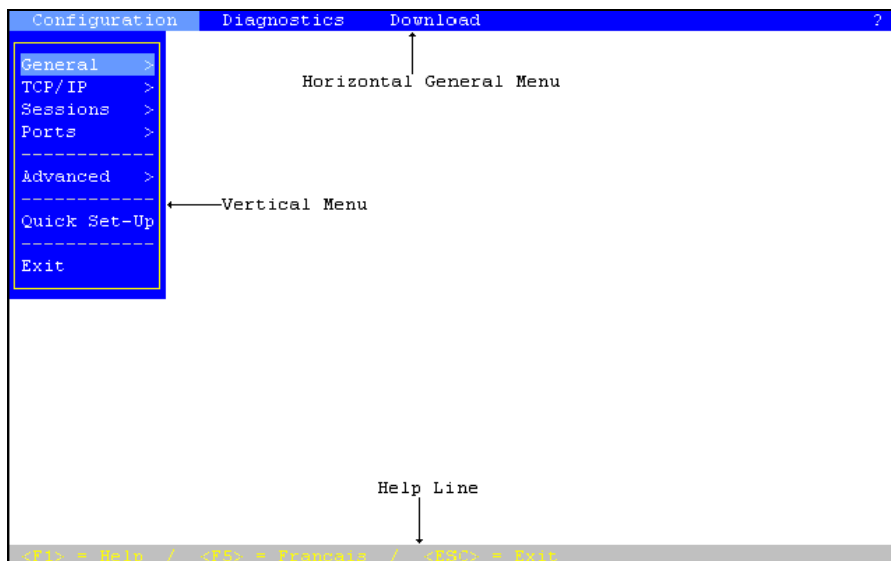

**a) The Horizontal General Menu**

Move through the menu with horizontal arrow keys. A different vertical menu will be displayed automatically as each item is traversed.

**b) Vertical Menus**

Move through vertical menus with vertical arrow keys. Confirm the selected command by pressing <CR>.

**Note:** the symbol '>', beside a vertical menu item, indicates that it is a sub-menu. Expand the sub-menu with the <CR> key, then move through it with vertical arrow keys.

### **c) Dialog Boxes**

Move through dialog boxes with vertical arrow keys.

Two types of fields are distinguished in a dialog box:

- Button: press <CR> to perform the associated action.
- Parameter: two types of value occur:
  - A free value (numeric or character string): the data capture mode is automatically enabled (see the next chapter).
  - A discrete value: press <SPACE> to show the permitted values or to display a list of values. Move through lists with vertical arrow keys; confirm the selected value by pressing <CR>. Press <Esc> to cancel.

Use the <Tab> key to move directly from the parameter field to the button field.

Select the [OK] button to save modifications and exit the dialog box. Select the [CANCEL] button or press <Esc> to exit the dialog box without saving modifications.

#### **A.1.3 - Enter Data**

When a 'free value' parameter field is selected, a value must be entered (it cannot be selected from a list).

**Note:** to indicate 'free value' mode, the cursor blinks at the beginning of the field.

During this mode the following keys are enabled:

- **<CR>**: confirmation
- **<Esc>**: abandon your changes
- **<horizontal arrows>** move the cursor within the character string
- **<Home>** and **<End>**: move the cursor directly to the beginning or the end of the string
- **<Del>**: delete the character at the cursor position
- **<Backspace>**: delete the character before the cursor position
- **<Insert>**: one of two editing modes:
  - Insertion (default): the cursor takes the form of a blinking line or
  - Overwrite: the cursor takes the form of a blinking block.

To enter characters with an ASCII code lower than 20 hexadecimal, use a backslash ('\') before the hexadecimal value. For instance, the 'Esc z' sequence can be encoded by '\1Bz'.

**Note:** when the character string is longer than the length of the field, two indicators are displayed at the left and at the right of the field.

#### **A.1.4 - Special Notation**

The set-up is a sequence of menus and sub-menus. Define an action by the path followed through the set-up tree (hierarchy), using the following notation:

**[item1]-[item2]-[action]**

For example, to perform the above **action**, select **item1** in the main menu, then select **item2** in the sub-menu.

#### **A.1.5 - Exiting the set-up**

To exit the set-up, select **[Configuration]-[Quit]**.

If changes have been made while in the set-up, a dialog box appears:

- Select **[YES]** to save the modifications and exit the set-up. The new AX3000 settings will then be stored in NVRAM (non-volatile memory).
- Select **[NO]** to abandon your changes and exit the set-up.

## A.2 - NETWORK OVERVIEW

### A.2.1 - Ethernet Addresses

AX3000 terminals (like other devices equipped for Ethernet networking) have a unique hardware address which is issued by the manufacturer and cannot be modified. This address is in the form of six hexadecimal bytes, separated by colons:

AX3000 Ethernet address format:  
00:A0:34:xx:xx:xx

Select the '?' command in the horizontal menu of the AX3000 set-up to see the AX3000 Ethernet address.

### A.2.2 - IP Address

Every device connected to an Ethernet network must have a single 32-bit address which encodes both the network and the host ID. Internet addresses (sometimes called «IP addresses») are usually written as four decimal numbers separated by decimal points ( '.' character).

There are three main classes of IP address:

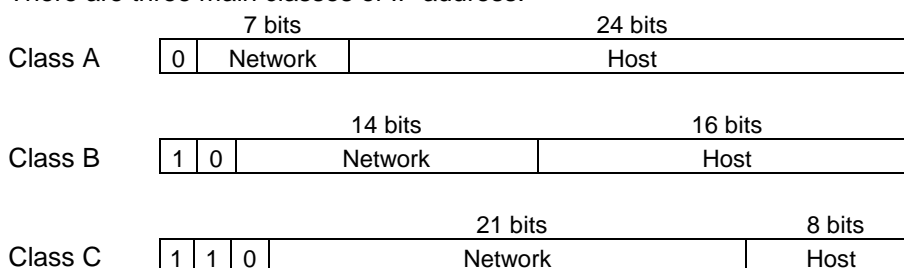

Thus every IP address occupies 4 bytes and contains both:

- A network address, and
- A host address.

**Note:** all devices attached to the same network must have the same class and the same network address. Each must have a **different** host address.

For example: an AX3000 connected, over a network, to a host with an IP address 192.1.168.40 (class C: three bytes for the Network address) must have the three first bytes of its address set to 192.1.168. The fourth byte cannot be equal to 40.

### **A.2.3 - Router**

Depending on the network topology, the AX3000 and the host may be installed on different physical networks and linked through one or several routers.

Two types of router can be used to access remote networks:

- A default router: this router knows how to reach many remote networks.
- Specific routers: in charge of one remote network.

The default router is only identified by an IP address.

The specific routers are identified by the following parameters:

- **Router IP address:** this router must be connected to the same network as the AX3000.
- **Destination IP Address:** IP address of the host or the network to be reached.
- **Destination Type:** two values:
  - **Host:** the destination is a single host,
  - **Network:** the destination is a whole local network (the class mask is applied to this IP address).

#### **Notes:**

- At the AX3000 level, the routing algorithm uses a specific router to reach the destination. If no specific router fits, the default router is used.
- The AX3000 doesn't support ICMP REDIRECT requests (dynamic routers are not supported).

**Example 1:** router 1 is used to reach the 192.168.2.xxx network and router 2 is used to reach the 192.1.1.xxx network:

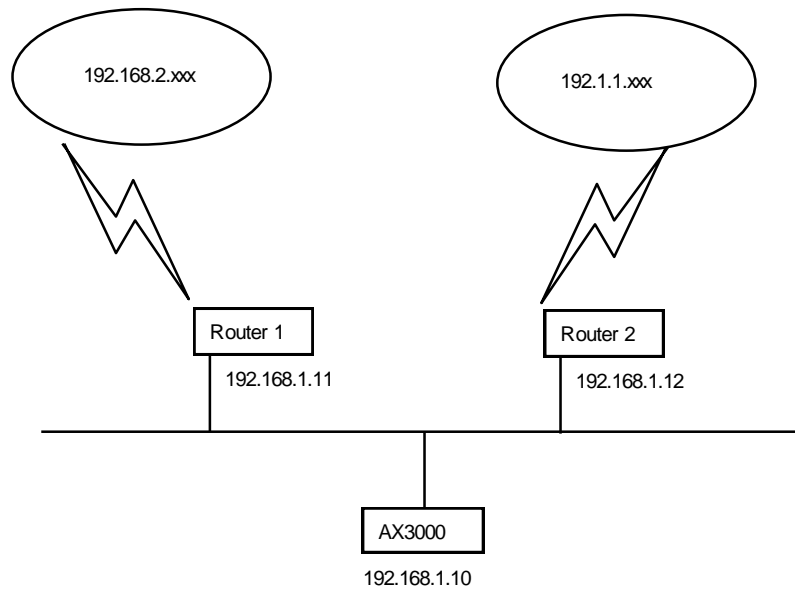

The AX3000 route table will show the following:

| Other Routers   |                |             |               |
|-----------------|----------------|-------------|---------------|
| Gateway IP addr | Target IP addr | Target Type | Netmask       |
| 192.168.1.11    | 192.168.2.0    | Network     | 255.255.255.0 |
| 192.168.1.12    | 192.1.1.0      | Network     | 255.255.255.0 |
| .....           | .....          | .....       | .....         |

At the bottom of the table, there are three buttons: 'OK', 'DELETE', and 'CANCEL'.



**Example 2:** router 1 is used to reach both networks (192.168.2.xxx and 192.1.1.xxx):

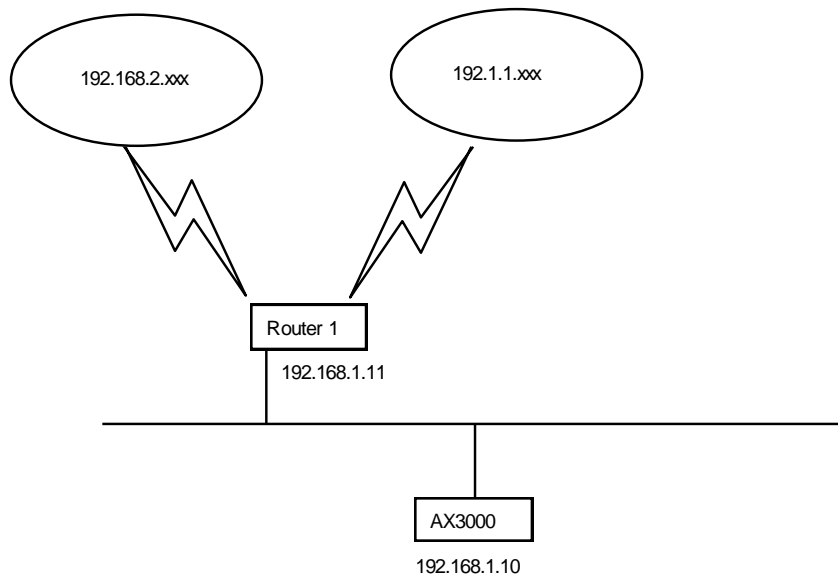

The AX3000 route table is:

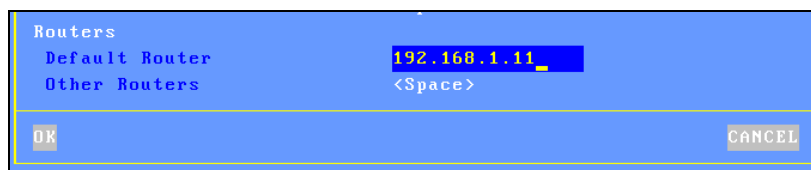

### A.3 - THE DHCP PROTOCOL

DHCP (Dynamic Host Configuration Protocol) is an industry standard protocol that lets a DHCP server (Unix, Windows, AS/400, etc.) allocate temporary IP addresses and other network parameters to terminals and PCs when they are powered on. This can greatly simplify managing large networks.

### **A.3.1 - Overview**

Here is a brief description of Axel's implementation DHCP:

- At boot time the AX3000 broadcasts DHCP requests to find the DHCP server.
- If a DHCP server is found and correctly set-up, an IP address, and subsequently other parameters are given to the AX3000.
- Before accepting the IP address the AX3000 can be set to check that the IP address given really is free (ARP protocol).
- The IP address offered is given temporarily. This duration is called the 'Lease Time'.
- If a lease time has been entered through the AX3000 Set-Up, this lease time is offered to the DHCP server, which may or may not accept this value.
- The AX3000 is expected to renew its lease before the lease expires. Once the lease has expired the AX3000 is no longer permitted to use the assigned IP address.
- Generally an IP address is dynamically assigned out of a pool of IP addresses. However static IP addresses can be associated to AX3000s (for instance when the AX3000's print server is used). This association is performed either by using the AX3000 Ethernet address or by using a 'Client Identifier' (which is a character string entered through the AX3000 Set-Up).
- The DHCP protocol can be considered as a superset of the BOOTP protocol. IP addresses can also be offered to AX3000s by a BOOTP server (in this case the 'lease time' is infinite).
- The AX3000 DHCP client protocol is compliant with RFCs 1533 and 1541.

This section deals only with the AX3000 DHCP protocol use. To set-up and enable a DHCP server please read your operating system's manual.

### **A.3.2 - Setting-Up the AX3000**

DHCP protocol is set through either the AX3000 Quick Set-Up or the AX3000 Interactive Set-up. For more information, see Chapters 2 and 3.

### **A.3.3 - Using the AX3000**

If the DHCP protocol is enabled the AX3000 automatically requests an IP

address on boot and the following dialog box is displayed:

```
DHCP: searching, please wait
```

**Note:** the search can be aborted by entering the set-up.

If a DHCP (or BOOTP) server is available an IP address is given after a few seconds. This dialog box is then cleared and the AX3000 follows its normal behavior: either the set-up idle is displayed (no automatic session is set) or an automatic connection is opened.

Further 'lease time' re-negotiations are totally invisible to the AX3000 user. Only error messages are displayed (see next chapter).

**Note:** enter the set-up to find out the AX3000 IP address or other parameters offered by the DHCP server.

### **A.3.4 - Errors**

#### ***a) Boot Time Failure***

The AX3000 automatically searches for a DHCP server on booting. If after 30 seconds no DHCP (or BOOTP) server answers the following dialog box is displayed:

```
DHCP NEGOTIATION FAILED  
  
Please contact your network administrator  
  
Press <F11> to reboot
```

At this stage two options are available:

- <F11>: rebooting the AX3000 to run the DHCP search again.
- <Ctrl><Alt><Esc>: entering the set-up to modify AX3000 settings.

**b) Re-negotiation Failure**

The lease time must be regularly re-negotiated (except if the IP address has been offered by a BOOTP server).

If a re-negotiation fails the following dialog box is displayed:

```
WARNING: DHCP REBINDING TOO LONG

The AX3000 could be disconnected in 2 minutes
Please log-off before automatic shutdown

Press <F11> to clear this message
```

This indicates that in two minutes the AX3000 will no longer be permitted to use the leased IP address and the session will be terminated

If after these two minutes, the re-negotiation has still failed, the following dialog box is displayed:

```
DHCP REBINDING FAILED

Please contact your network administrator

Press <F11> to reboot
```

All current sessions (telnet, tty, lpd, etc.) will have been closed (i.e. lost).

**Note:** the AX3000 Trace Mode allows a trace of data exchanged between the AX3000 and the DHCP server (see Chapter 3.1). This is useful to diagnose problems.

**A.4 - THE DNS PROTOCOL**

The DNS protocol (Domain Name System) allows names to be 'resolved' by the AX3000. Resolving is retrieving an IP address associated with a name.

### **A.4.1 - Overview**

A domain (computer network) can be considered as a tree, with branches (nodes) such as hubs, switches, routers, print servers etc, and leafs, for example PCs, terminals and printers.

The domain system makes no distinction between the use of interior nodes and the leafs, and this documentation uses the term "nodes" to refer to both. (I.e. any network resource).

Each node has a name (**Label**) which must be unique to other nodes at the same level, but not necessarily unique within the whole network.

#### **Label syntax:**

- Permissible characters are letters (a..z to A..Z), numbers (0..9) and the hyphen (-).
- A Label must begin by a letter and be ended by a letter or a number.
- The resolution is not case-sensitive.

The domain name of a node is the list of the labels on the path from the node to the root of the tree. A dot is used to separate each label. Two types of host names can be distinguished within the AX3000:

- **A full name:** one or more dots are included in the name.  
Example: "www.axel.com"
- **An incomplete name:** no dots are used. The resolution procedure concatenates another character string to this name (the default DNS domain name). For more information see Chapter 3.1.2.  
Example: "as400" is concatenated with "servers.axel.com" to create a full name of "as400.servers.axel.com"

A host name is only resolved if the IP address is needed. (I.e. to open a session or to ping).

**Note:** a name is resolved for each connection attempt, even if its IP address has been obtained by a previous resolution.

## **A.4.2 - Resolving a Name**

### ***a) Resolution Strategy***

To resolve a name, a DNS request is sent by the AX3000. A DNS request contains the destination DNS server IP address and the name to be resolved.

To resolve a name possibly more than one DNS request is needed (if one or more default DNS domains are defined). The resolution process is stopped either when the AX3000 receives a positive response from a DNS server (success: an IP address is associate to this name) or when all the DNS requests has been sent and no positive response has been received (failure: the name is not resolved).

The order of the requests sent to resolve a hostname is called the resolution strategy.

The resolution strategy depends on both:

- Whether or not a domain name is declared,
- Whether the name to resolve is complete.

If no default DNS domain is defined in the AX3000 Set-Up, the resolution is done with the name itself regardless of whether the name is full or not.

If one or more default DNS domains are defined, the resolution strategy depends on the name:

- Full name: the resolution is first done with this name. If unsuccessful new resolutions are performed by concatenating the full name with the defined DNS domains.
- Incomplete Name: the resolutions are first done with the defined default DNS domains. If unsuccessful a new resolution is performed with this incomplete name.

**Example of name resolutions:** looking at the host table in Chapter 3.1.3 the name resolution attempts are:

- **as400**: this is not a full name, the resolution is first made with the first DNS domain (as400.servers.axel.com). Then, in event of failure, with the second DNS domain (as400.terminals.axel.com). Then, in event of failure, the resolution is made with the name itself (as400).

- **linux**: an IP address is associated. No DNS resolution.
- **www.axel.com**: this is a full name. The resolution is first made with the name itself (www.axel.com). Then, in event of failure, the resolution is made with the first DNS domain (www.axel.com.servers.axel.com). Then, in event of failure, with the second DNS domain (www.axel.com.terminals.axel.com).

### ***b) Resolution Method***

To resolve a name, the AX3000 sends DNS requests to the DNS server(s).

If a DNS server sends back a positive response, then the IP address is found and the resolution operation is completed. If not two cases of failure are possible:

- **Receiving a negative response**: the name is not known by this DNS server. The AX3000 will retry with a new DNS request or with the second DNS server.
  - **No response (time-out)**: after a few seconds the DNS server has not sent back a response. The AX3000 resends the same request to the DNS server.
- Note**: after 4 time-out errors on the same DNS server, this server is "removed" from the resolution operation.

**Note**: if a response previously considered as a time-out error is received, this response is treated as a valid response (positive or negative).

The AX3000 requests a **recursive search** to the DNS servers (and not iterative search). This means that the DNS server must search itself for a DNS server which is able to resolve the required name.

The resolution operation depends on the number of DNS servers. These are the steps for a one-server resolution and a two-server resolution.

#### **One DNS Server:**

- 1 - A DNS request is sent to the server.
- 2 - In event of no response, this request is sent again (4 times max.).
- 3 - In event of negative answer, the resolution is aborted.
- 4 - If other requests can be sent (default DNS domains are defined), go back to step 1.

**Two DNS Servers:**

- 1 -A DNS request is sent to the server 1.
- 2 -In event of no response from server 1, this request is sent to the server 2.
- 3 -In event of no response from server 2, go back to step 1 (4 times max.).
- 4 -In event of negative answer from any server, the resolution is aborted.
- 5 -If other requests can be sent (using default DNS domains are defined), go back to step 1.

Example: looking at the screen shots of the Chapter 3.1, these are the DNS requests sent to resolve "as400" with 2 DNS servers and 2 default DNS domains (of course this process is stopped if one DNS server sends back a positive response):

- "as400.servers.axel.com" to DNS server 1
- "as400.servers.axel.com" to DNS server 2
- "as400.terminals.axel.com" to DNS server 1
- "as400.terminals.axel.com" to DNS server 2
- "as400" to DNS server 1
- "as400" to DNS server 2

***c) Messages Displayed on the AX3000 Screen***

To open a session the AX3000 must resolve the host name (if no IP address has been associated through the set-up).

This is a screen-shot example when the resolution successes:

```
Connecting to as400.servers.axel.com:23 (Telnet)...
Session number 1
Resolving...
Resolved: 192.168.1.180
Connected
```

**Explanation:** the AX3000 attempts to resolve "as400.servers.axel.com". The resolution process returns the IP address which is 192.168.1.180.



In the event of a problem, the "Resolved: a.b.c.d" message is replaced by an error message. For example:

```
Connecting to as400.servers.axel.com:23 (Telnet)...
Session number 1
Resolving...
Srv: domain not found
Press <Ctrl><Alt><Shift><D> to close this session
```

**Error messages:** error messages reported by the DNS server begins with Srv. Error messages from the terminal begin with "Loc". The main messages are:

- **Srv: domain not found:** the name doesn't exist within this domain.
- **Srv: refused query:** the DNS servers refuses to respond to the request. This could be due to a DNS server security function.
- **Loc: no DNS server defined:** no DNS server has been defined through the AX3000 Set-Up.
- **Loc: name syntax error:** the syntax of the name to resolve is not correct (for example two consecutive dots: as400.servers).
- **Loc: timeout:** no DNS server responds
- **Loc: no memory:** due to a temporary memory overload, the AX3000 can not process the name resolution. Retry later.

When the resolution fails, the session must be manually closed. This is done by pressing <Ctrl><Alt><Shift><D>.

#### **A.4.3 - Publishing the Terminal Name**

The terminal name may be registered with the DNS server. This can be done by the DHCP server or by the terminal itself.

##### ***a) By the DHCP Server***

**Important:** the DHCP server must support the DDNS (Dynamic DNS) function.

To register the terminal name by the DHCP server:

- Enable the DHCP protocol (in [Configuration-[TCP/IP]-[Interface]])
- Set "DNS Server Update" to "by the DHCP server" (in [Configuration]-[TCP/IP]-[DNS])

Because the DNS server is updated by the DHCP server the information about

the type ("direct" or "direct / reverse") and the result (success or failure) of the DNS update is not returned to the terminal.

**b) By the terminal**

For the terminal to register itself, set "DNS Server Update" to "by the terminal" (in [Configuration]-[TCP/IP]-[DNS])

**Note:** the DNS server will be updated only if the terminal name is a full name: ended by a DNS domain (i.e. FQDN).

By default the terminal updates "direct" and "reverse" DNS server entries. If the DHCP protocol is enabled and if the DHCP server announces a change of reverse updates, the terminal will perform only a "direct" update.

For a "direct" update, two entries are added in the DNS server database:

- A "Host" type entry, containing the terminal IP address,
- A "Text" type entry, containing the terminal signature.

For a "reverse" update, one entry is added: a "Pointer" type entry, containing the terminal's full name.

**Note:** the signature allows the terminal to check its "Host" type entry. If the check fails (i.e. no associated signature or wrong associated signature) the terminal's behavior during the DNS server update depends on the value of the set-up parameter "**Action on Error**" (see Chapter 3.1):

- **Display an error:** a red dialog box is displayed. The user may reboot the terminal or enter the set-up.
- **Continue the update:** the entries ("Host", "Text" and "Pointer") are overwritten.
- **Cancel the update:** the DNS update is aborted but the terminal is available for use.

The type ("direct" or "direct / reverse") and the result (success or failure) of the DNS update are returned to the terminal and are available in the terminal set-up. See chapter 9.3.

## A.5 - REMOTE SET-UP CONFIGURATION FILE FORMAT

A configuration file can list some or all AX3000 set-up parameters.

The configuration file begins with the header label (`BEGIN_AX_SETUP`) and ends with the trailer label (`END_AX_SETUP`).

Example:

```
BEGIN_AX_SETUP V1.1
# this is a comment
tcp_host1_name=vangogh
...
END_AX_SETUP
```

**Note:** lines beginning with '#' are treated as comments and ignored.

The set-up parameters may be grouped as follows:

|                |                                            |
|----------------|--------------------------------------------|
| Ethernet:      | Ethernet interface parameters,             |
| TCP/IP:        | network environment,                       |
| AUX% Port:     | port service and communication parameters, |
| Parallel Port: | port service,                              |
| Usb% Port:     | port service,                              |
| Net% Port:     | port service,                              |
| Terminal:      | global parameters (screen, keyboard, etc), |
| Multi-session: | session numbers, hot keys, etc             |
| Session %:     | session parameters.                        |

Several formats are available for set-up parameter values:

|                    |                                                                                                 |
|--------------------|-------------------------------------------------------------------------------------------------|
| List:              | the possible values are listed (the character ' ' is used as a separator). Example: (yes   no). |
| Number:            | maximum and minimum values are given.                                                           |
| IP address format: | the IP address format is a.b.c.d.                                                               |
| Character string:  | maximum length is given.                                                                        |

**Note:** an ASCII character can be represented by its hexadecimal ASCII code, preceded by a backslash character (e.g.: `\1B` represents Escape and `\\` represents a backslash).

|                  |                                                                                                                  |
|------------------|------------------------------------------------------------------------------------------------------------------|
| 8-color format:  | the 8 available colors are black, red, green, brown, blue, magenta, cyan and white.                              |
| 16-color format: | the 8 additional available colors are grey, lt-magenta, lt-green, hi-white, lt-blue, lt-red, lt-cyan and yellow. |
| Resolution:      | a resolution is encoded as <b>WxH-FHz</b> .<br>Examples: 800x600-60Hz or 1440x900-75Hz.                          |

In the following parameter lists, the possible values are bracketed after each set-up parameter.

A configuration file can either be created using a text editor, or obtained from an already configured TCP/IP AX3000 (by using **setup\_get** remote command).

When a configuration file is obtained from an AX3000, the inactive parameters (undefined hosts, print server unused, coloring mode disabled, etc) are commented out.

The sample configuration file, shown in the following pages, is typical of a file obtained from an already configured AX3000. Notes and headings have been inserted for clarification and would not appear in the file.

### Header

```
BEGIN_AX_SETUP V1.1
#####
#           TCP/IP AX3000 Platine Terminal           #
#                                                                 #
# Ethernet address: 00:A0:34:00:27:10                #
# Firmware: FK5.BV2.1a/TCP.FR.0826a.STD            #
#####
#
# RESET_CMOS
```

**Note:** the `RESET_CMOS` command allows all the set-up parameters (except the AX3000 IP address) to be reset. This line can be deleted or set as a comment.

### Substitution Commands

```
axname_encoding_string=          (yes | no)
```

Enabling "axname\_encoding\_string" allows some set-up parameters to contain 'substitution commands'. This allows variables such as the terminal name and the session number. The substitution is done when a set-up file is sent to the terminal.

☺: this function is useful when multiple terminals are configured with the same set-up file, but each terminal requires certain unique parameters.

**Notes:**

- It works only through the remote set-up function. (It's not available with the interactive set-up).
- Some set-up parameters are not supported by this function: the terminal name, the passwords, the pre and post-printing sequences and the transparent mode sequences.

The substitution commands are:

- <\$> is the parameter "ethernet\_axname"
- <#> is the screen session number (1 to 6) or the port session number (AUX1=1, AUX2=2, PARALLEL=3, USB1=4, USB2=5, USB3=6, USB4=7, NET1=8, NET2=9).
- <\$(X,Y)> is an "ethernet\_axname" sub-string (start X, length Y).

**Notes:**

- If X is greater than the "ethernet\_axname" length, the substring is empty.
- If X+Y is greater than the "ethernet\_axname" length the substring is truncated.
- In event of syntax error the substitution is not done.

**Example:** if the terminal name is "axel201234":

```
TERM<$(7,4)>          => TERM1234
TERM<$(7,10)>         => TERM1234
TERM<$(20,7)>         => TERM
TERM<$(20,A)>         => TERM<$(20,A)>
<$(1,2)><$(7,4)><#>    => ax1234-2 (ex.: session 2 or AUX2)
```

**Ethernet Parameters**

```
ethernet_link=          (Auto-sense | 10BT HD | 10BT FD |
                        100BT HD | 100BT FD)
```

```

ethernet_dhcp_used=no                (yes | no)
ethernet_dhcp_netmask=              (yes | no)
ethernet_dhcp_defrouter=            (yes | no)
ethernet_dhcp_DNSserver=           (yes | no)
ethernet_dhcp_srchdomain=          (yes | no)
ethernet_dhcp_leasetime=           (number)
ethernet_dhcp_clientid=            (character string, 10 char max.)
ethernet_dhcp_userclassid=         (character string, 32 char max.)
ethernet_dhcp_tracemode=           (yes | no)
ethernet_dhcp_checkipaddr=         (yes | no)
#ethernet_ipaddr=192.168.1.241      (IP address format)
#ethernet_netmask=255.255.255.0    (IP address format)
ethernet_axDNS=default DNS dom     (character string, 64 char max.)
ethernet_updateDNS=dhcp            (no | dhcp | terminal)
ethernet_dns_servIP%               (IP address format)
ethernet_dns_domain%               (character string, 64 char max.)
ethernet_dns_FQDNexists=           (display error | abort | continue)
ethernet_dns_tracemode=no          (yes | no)
ethernet_router%_ip=               (IP address format)
ethernet_router%_target=           (IP address format | default)
ethernet_router%_mask=             (IP address format)

```

**Note:** when a configuration file is obtained from an AX3000, the "ethernet\_ipaddr" and "ethernet\_netmask" parameters are commented out.

#### **Router explanation:**

- The "ethernet\_router%\_ip" parameter is the router IP address, the "ethernet\_router%\_target" parameter is the target host (or network) IP address and the "ethernet\_router%\_mask" parameter is an optional network mask used to reach the target network.
- The default router is encoded by "ethernet\_router%\_ip" set to "0.0.0.0", "ethernet\_router%\_target" set to "default" and "ethernet\_router%\_mask" set to "0.0.0.0".

#### **TCP/IP Parameters**

```

tcp_axname=axel203039              (character string, 64 char max.)
tcp_comment_string=                (character string, 32 char max.)

```

```

tcp_host%_name=vangogh      (character string, 64 char max.)
tcp_host%_ip=192.168.1.252 (IP address format)
tcp_ping_setip=yes         (yes | no)
tcp_tnsetup_port=4096      (number)
tcp_remoteCtrl_allowed=no  (yes | no)
tcp_remoteCtrl_port=4097   (number)
tcp_remoteCtrl_enpassword= (character string, 15 char max.)
tcp_remoteCtrl_password=   (character string, 5 char max.)
tcp_remoteCtrl_see=no      (no | colors | overscan |
                           statline)
tcp_network_discover=no    (yes | no)

```

### **Auxiliary Ports and Logical Ports Parameters**

#### **a) AUX1 and AUX2 Ports**

In the following section of the file, for ease of reading the auxiliary port number (1 or 2) has been represented by the '%' character. In a real configuration file, the parameters for each auxiliary port would, of course, be listed.

```

aux%_service=none          (none | rtty | printd | lpd
                           rcmd | rtelnet | tty | Prt5250
                           Prt3270)
aux%_service_name=aux1     (character string, 8 char max.)
aux%_associate_host=vangogh (character string, 64 char max.)
aux%_service_tcpport=23    (number)
aux%_associate_term=ansi   (character string, 8 char max.)
aux%_associate_autoconn=yes (yes | no)
aux%_associate_reconn=yes  (yes | no)
aux%_rtty_accept=no       (yes | no)
aux%_filter_nl=no         (yes | no)
aux%_preprint_string=     (character string, 48 char max.)
aux%_postprint_string=    (character string, 48 char max.)
aux%_associate_devname=PRN (character string, 10 char max.)
aux%_associate_msgqname=QSYSOPR (character string, 10 char max.)
aux%_associate_msgqlib=*LIBL (character string, 10 char max.)
aux%_associate_font=11    (character string, 10 char max.)
aux%_associate_mfrtypmdl=*NONE (character string, 10 char max.)
aux%_associate_pprsrcl=   (character string, 10 char max.)

```

```

aux%_associate_pprsrc2=*NONE      (character string, 10 char max.)
aux%_associate_envelope=*NONE    (character string, 10 char max.)
aux%_associate_ascii899=no      (yes | no)
aux%_associate_wscstname=       (character string, 8 char max.)
aux%_associate_wscstlib=       (character string, 8 char max.)
aux%_associate_transp=         (yes | yes-hexa)
aux%_associate_transp-seq=     (character string, 4 char max.)
aux%_associate_prn=            (yes | no)
aux%_associate_prnname=        (chaîne de 16 caractères max.)
aux%_associate_prndriver=       (chaîne de 64 caractères max.)
aux%_associate_prntimer=15     (number)
aux%_associate_com=yes         (yes | no)
aux%_associate_comname=        (number)
aux%_associate_comdsr=         (follow CTS | follow CD |
                                always low | allows up)

aux%_tcp_window=1024           (number)
aux%_tcp_mss=512               (number)
aux%_tcp_ttl=64                (number)
aux%_tcp_setport=random        (random | fixed)
aux%_tcp_nagle=disable         (disable | enable)
aux%_tcp_keepalive=no          (yes | no)
aux%_tcp_keepaliveval=120      (number)
aux%_use=bi-directional        (printer | bi-directional)
aux%_speed=38400               (300 | 600 | 1200 | 2400 | 4800
                                9600 | 19200 | 38400 | 57600
                                115200)

aux%_data                       (7-1-none | 7-1-odd | 7-1-even
                                8-1-none | 8-1-odd | 8-1-even
                                7-2-none | 7-2-odd | 7-2-even
                                8-2-none | 8-2-odd | 8-2-even)

aux%_tx_hdsk=dtr                (none | xon-xoff | xany-xoff |
                                xpc | cts)

aux%_rx_hdsk=dtr                (none | xon-xoff | xpc |
                                dtr | rts)

aux%_detect=none                (none | cts)
aux%_dtr_init                    (high | low)
aux%_rts_init                     (high | low)
aux%_tx_fifo=yes                 (yes | no)
aux%_seq=                         (character string, 19 char max.)

```



**b) Parallel Port**

```

parallel_service=none          (none | rtty | printd | lpd | rcmd
                               Prt5250 | Prt3270 | tty)
parallel_service_name=parallel (character string, 8 char max.)
parallel_associate_host=vangogh (character string, 64 char max.)
parallel_associate_term=ansi   (character string, 8 char max.)
parallel_associate_autoconn=yes (yes | no)
parallel_associate_reconn=yes  (yes | no)
parallel_service_tcpport=2050  (number)
parallel_rtty_accept=no        (yes | no)
parallel_filter_nl=no          (yes | no)
parallel_preprint_string=      (character string, 48 char max.)
parallel_postprint_string=     (character string, 48 char max.)
parallel_associate_devname=    (character string, 10 char max.)
parallel_associate_msgqname=   (character string, 10 char max.)
parallel_associate_msgqlib=    (character string, 10 char max.)
parallel_associate_font=11     (character string, 10 char max.)
parallel_associate_mfrypmdl=   (character string, 10 char max.)
parallel_associate_pprsrc1=    (character string, 10 char max.)
parallel_associate_pprsrc2=    (character string, 10 char max.)
parallel_associate_envelope=   (character string, 10 char max.)
parallel_associate_ascii899=no (yes | no)
parallel_associate_wscstname=  (character string, 8 char max.)
parallel_associate_wscstlib=  (character string, 8 char max.)
parallel_associate_transp=     (yes | yes-hexa)
parallel_associate_transp-seq= (character string, 4 char max.)
parallel_tcp_window=1024       (number)
parallel_tcp_mss=512           (number)
parallel_tcp_ttl=64            (number)
parallel_tcp_setport=random    (random | fixed)
parallel_tcp_nagle=disable     (disable | enable)
parallel_tcp_keepalive=no      (yes | no)
parallel_tcp_keepaliveval=120  (number)
parallel_operating_mode=       (optimised | standard)
parallel_sup_signals=          (none | select | paper | both)

```

**c) USB Logical Ports**

In the following section of the file, for ease of reading the USB logical port number (1 to 4) has been represented by the '%' character. In a real configuration file, the parameters for each port would, of course, be listed.

```

usb%_service=none          (none | rtty | printd | lpd | rcmd
                           rtelnet | Prt5250 | Prt3270
                           tty)
usb%_use=bi-directional   (printer | bi-directional)
usb%_speed=38400          (300 | 600 | 1200 | 2400 | 4800
                           9600 | 19200 | 38400 | 57600
                           115200)
usb%_data                  (7-1-none | 7-1-odd | 7-1-even
                           8-1-none | 8-1-odd | 8-1-even
                           7-2-none | 7-2-odd | 7-2-even
                           8-2-none | 8-2-odd | 8-2-even)
Usb%_flow_ctrl=rts-cts   (none | rts-cts | dtr-dsr)
usb%_rts_init              (high | low)
usb%_dtr_init              (high | low)
usb%_service_name=Usb%   (character string, 8 char max.)
usb%_associate_host=vangogh (character string, 64 char max.)
usb%_associate_term=ansi  (character string, 8 char max.)
usb%_associate_autoconn=yes (yes | no)
usb%_associate_reconn=yes (yes | no)
usb%_service_tcpport=2050 (number)
usb%_rtty_accept=no      (yes | no)
usb%_filter_nl=no        (yes | no)
usb%_preprint_string=    (character string, 48 char max.)
usb%_postprint_string=   (character string, 48 char max.)
usb%_associate_devname=   (character string, 10 char max.)
usb%_associate_msgqname=  (character string, 10 char max.)
usb%_associate_msgqlib=   (character string, 10 char max.)
usb%_associate_font=11    (character string, 10 char max.)
usb%_associate_mfrypmdl=  (character string, 10 char max.)
usb%_associate_pprsrcl=   (character string, 10 char max.)
usb%_associate_ppsrc2=    (character string, 10 char max.)
usb%_associate_envelope=  (character string, 10 char max.)
usb%_associate_ascii899=no (yes | no)

```

```

usb%_associate_wscstname=      (character string, 8 char max.)
usb%_associate_wscstlib=      (character string, 8 char max.)
usb%_associate_transp=        (yes | yes-hexa)
usb%_associate_transp-seq=    (character string, 4 char max.)
usb%_tcp_window=1024          (number)
usb%_tcp_mss=512              (number)
usb%_tcp_ttl=64               (number)
usb%_tcp_setport=random       (random | fixed)
usb%_tcp_nagle=disable        (disable | enable)
usb%_tcp_keepalive=no         (yes | no)
usb%_tcp_keepaliveval=120     (number)

```

#### **d) TCP Logical Ports**

In the following section of the file, for ease of reading the TCP logical port number (1 to 4) has been represented by the '%' character. In a real configuration file, the parameters for each port would, of course, be listed.

```

net%_host=                     (character string, 64 char max.)
net%_port=9100                  (number)
net%_inactivity_to=60          (number)
net%_service=none              (none | rtty | printd | lpd | rcmd
                                Prt5250 | Prt3270 | tty)
net%_service_name=Usb%         (character string, 8 char max.)
net%_associate_host=vangogh    (character string, 64 char max.)
net%_associate_term=ansi       (character string, 8 char max.)
net%_associate_autoconn=yes    (yes | no)
net%_associate_reconn=yes      (yes | no)
net%_service_tcpport=2050      (number)
net%_rtty_accept=no            (yes | no)
net%_filter_nl=no              (yes | no)
net%_preprint_string=          (character string, 48 char max.)
net%_postprint_string=         (character string, 48 char max.)
net%_associate_devname=        (character string, 10 char max.)
net%_associate_msgqname=       (character string, 10 char max.)
net%_associate_msgqlib=        (character string, 10 char max.)
net%_associate_font=11         (character string, 10 char max.)
net%_associate_mfrrtpmdl=      (character string, 10 char max.)
net%_associate_pprsrcl=        (character string, 10 char max.)

```

|                            |                                  |
|----------------------------|----------------------------------|
| net%_associate_pprsrc2=    | (character string, 10 char max.) |
| net%_associate_envelope=   | (character string, 10 char max.) |
| net%_associate_ascii899=no | (yes   no)                       |
| net%_associate_wscstname=  | (character string, 8 char max.)  |
| net%_associate_wscstlib=   | (character string, 8 char max.)  |
| net%_associate_transp=     | (yes   yes-hexa)                 |
| net%_associate_transp-seq= | (character string, 4 char max.)  |
| net%_tcp_window=1024       | (number)                         |
| net%_tcp_mss=512           | (number)                         |
| net%_tcp_ttl=64            | (number)                         |
| net%_tcp_setport=random    | (random   fixed)                 |
| net%_tcp_nagle=disable     | (disable   enable)               |
| net%_tcp_keepalive=no      | (yes   no)                       |
| net%_tcp_keepaliveval=120  | (number)                         |

**e) Service Table**

**Note:** Depending on the associated service, some parameters can be inactive. They are unmarked in the following table and commented out in the configuration file:

|                      | Available Services |      |     |      |         |     |      |      |
|----------------------|--------------------|------|-----|------|---------|-----|------|------|
|                      | printd             | rtty | lpd | rcmd | rtelnet | tty | 5250 | 3270 |
| service_name         |                    |      | 3   | 3    |         |     |      |      |
| service_tcpport      | 3                  | 3    |     |      | 3       | 3   | 3    | 3    |
| preprint_string      |                    |      | 3   | 3    |         |     |      | 3    |
| preprint_portrait    |                    |      | 3   | 3    |         |     |      | 3    |
| preprint_landscape   |                    |      | 3   | 3    |         |     |      | 3    |
| postprint_string     |                    |      | 3   | 3    |         |     |      | 3    |
| filter_nl            | 3                  | 3    | 3   |      |         |     |      | 3    |
| associate_host       |                    |      |     |      | 3       | 3   | 3    | 3    |
| associate_term       |                    |      |     |      | 3       |     | 3    |      |
| associate_autoconn   |                    |      |     |      | 3       |     | 3    | 3    |
| associate_reconn     |                    |      |     |      | 3       | 3   | 3    | 3    |
| associate_devname    |                    |      |     |      |         |     | 3    | 3    |
| associate_msgqname   |                    |      |     |      |         |     | 3    |      |
| associate_msgqlib    |                    |      |     |      |         |     | 3    |      |
| associate_font       |                    |      |     |      |         |     | 3    |      |
| associate_mfrtypmdl  |                    |      |     |      |         |     | 3    |      |
| associate_pprsrc1    |                    |      |     |      |         |     | 3    |      |
| associate_pprsrc2    |                    |      |     |      |         |     | 3    |      |
| associate_envelope   |                    |      |     |      |         |     | 3    |      |
| associate_ascii899   |                    |      |     |      |         |     | 3    |      |
| associate_wscstna    |                    |      |     |      |         |     | 3    |      |
| associate_wscstlib   |                    |      |     |      |         |     | 3    |      |
| associate_transp     |                    |      |     |      |         |     | 3    |      |
| associate_transp-seq |                    |      |     |      |         |     | 3    |      |

**Terminal Parameters**

```

#term_encrypted_password= (character string, 15 char max.)
#term_password= (character string, 15 char max.)
term_language= (french | english)
term_screen=CRT-standard (CRT-standard | TFT)
term_defaultc_geometry= (resolution format)
term_default_depth= (8bpp | 16bpp | 24bpp)
term_setup_mode=graphic (graphic | text)
term_sessman_color= (colors)
term_sessman_mode=desktop (desktop | classic)
term_screensaver=yes (no | yes | yes-kbd-only)
term_screensaver_energystar=no (no | yes)
term_screensaver_delay=2 (number lower than 31)
term_screensaver_enpassword= (character string, 15 char max.)
term_screensaver_password= (character string, 5 char max.)
term_keyboard=french (french | german | italian
spanish | belgian | english
american | portuguese | dutch
swiss-german | swiss-french |
turk-q | turk-f | iceland)

term_hotkeys_enable=yes (no | yes)
term_numlock=on (on | off)
term_capslock=on (on | off)
term_local_beep=long (no | long | short | very long)
term_remote_beep=long (no | long | short | very long)
term_keydelay=mediun (low | medium | high)
term_keyspeed=low (low | medium | high)
term_audio_volume=5 (number)
term_audio_beep=By Buzzer (By Buzzer | By Audio Device)
term_msclick_inverted=no (no | yes)
term_mouse_speed (no | yes)
term_defaultport=aux1 (none | aux% | parallel | usb% |
net%)

term_preprint_string= (character string, 48 char max.)
term_postprint_string= (character string, 48 char max.)
term_touchscr_type=ELO (ELO | MicroTouch | Liyitec)
term_touchscr_port=usb1 (no | aux1 | aux2 | usb%)
term_touchscr_xlow=0 (number)

```

|                              |                                    |
|------------------------------|------------------------------------|
| term_touchscr_xhigh=0        | (number)                           |
| term_touchscr_ylow=0         | (number)                           |
| term_touchscr_yhigh=0        | (number)                           |
| term_touchscr_accuracy=20    | (number)                           |
| term_usbptr_events=          | (click   all)                      |
| term_usbptr_transpose=       | (no   yes)                         |
| term_autoconf_force=no       | (no   yes)                         |
| term_autoconf_to=            | (number)                           |
| term_autoconf_dhcp=          | (no   yes)                         |
| term_autoconf_name=          | (character string, 64 char max.)   |
| term_autoconf_ip=            | (IP address format)                |
| term_autoconf_port=          | (number)                           |
| term_usbdriveredir=          | (read-only   read-write)           |
| term_driveletter=            | (1 character)                      |
| term_gmt=+00:00              | (GMT format +-hh:mm)               |
| term_gmt_name=Greenwich      | (character string, 32 char max.)   |
| term_daylight=yes            | (no   yes)                         |
| term_summer_day=last         | (first   ...   fourth   last)      |
| term_summer_dayofweek=sunday | (sunday   monday   ...   saturday) |
| term_summer_month=march      | (january   ...   december)         |
| term_summer_hour=2           | (numeric)                          |
| term_winter_day=last         | (first   ...   fourth   last)      |
| term_winter_dayofweek=sunday | (sunday   monday   ...   saturday) |
| term_winter_month=october    | (january   ...   december)         |
| term_winter_hour=3           | (numeric)                          |
| term_win_kbcode=409          | (hexadecimal)                      |
| term_ScardReader%_Id=        | (number)                           |
| term_ScardReader%_vendor=    | (character string, 32 char max.)   |
| term_ScardReader%_ifd=       | (character string, 32 char max.)   |
| term_ScardReader%_force=     | (yes   no)                         |

### **Multi-session Parameters**

|                              |                                                           |
|------------------------------|-----------------------------------------------------------|
| multi_nbsession=6            | (number in range 1 to 6)                                  |
| multi_nbpage=1               | (number in range 1 to 6)                                  |
| multi_statusline=yes         | (yes   no)                                                |
| multi_statusline_masking=yes | (yes   no)                                                |
| multi_intro=alt              | (alt   shift   ctrl   alt-shift<br>ctrl-shift   ctrl-alt) |

```

                                ctrl-alt-shift)
multi_s%=112                    (number in range 2 to 123)

```

### **Session Parameters**

In the following section of the file, for ease of reading the session number (1 to 6) has been represented by the '%' character. In a real configuration file, the parameters for each session would, of course, be listed.

```

s%_predefined_setup=ansi      (rdp | ica | vnc | 5250 | 3270 |
                               Citrix Xen Desktop | VMWARE VDM
                               ansi | ansi dos | unix sco 3.2.2
                               unix sco 3.2.4 | sco openserver
                               xenix sco | unix svr4 | ansi mos
                               ansi interactive | ansi rs 6000
                               ansi data general | vt220 | vt52
                               c332 | sm9400 | sm9412
                               ato300 | hft)

s%_associate_protocol=telnet  (telnet | tty | ssh | serial)
s%_serial_main=aux1           (aux1 | aux2 | usb%)
s%_serial_aux=aux2            (aux1 | aux2 | usb%)
s%_associate_host=vangogh     (character string, 64 char max.)
s%_secondary_host=           (character string, 64 char max.)
s%_associate_term=ansi        (character string, 10 char max.)
s%_associate_devname=         (character string, 20 char max.)
s%_associate_autoconn=yes     (yes | no)
s%_associate_reconn=yes       (yes | no)
s%_associate_label=view 1     (character string, 10 char max.)
s%_associate_tcpport          (number)
s2_display_format=           (default | customized |
                               full screen)

s2_display_geometry=         (resolution format)
s2_display_depth=            (8bpp | 15 bpp | 16bpp | 24bpp)
s3_alternate_geometry=       (default | 800x600)
s%_associate_realport        (number)
s%_associate_to               (yes | no)
s%_associate_toval            (number)
s%_associate_sshusername=     (character string, 60 char max.)
s%_associate_sshenpassword=   (character string, 30 char max.)

```



|                           |                                                                                                 |
|---------------------------|-------------------------------------------------------------------------------------------------|
| s%_associate_sshpassword= | (character string, 10 char max.)                                                                |
| s%_associate_sshcmd=      | (character string, 60 char max.)                                                                |
| s%_associate_script=      | (character string, 60 char max.)                                                                |
| s%_associate_username=    | (character string, 10 char max.)                                                                |
| #s%_associate_enpassword= | (character string, 30 char max.)                                                                |
| #s%_associate_password=   | (character string, 10 char max.)                                                                |
| s%_associate_progname=    | (character string, 10 char max.)                                                                |
| s%_associate_menuname=    | (character string, 10 char max.)                                                                |
| s%_associate_libname=     | (character string, 10 char max.)                                                                |
| s%_tcp_window=1024        | (number)                                                                                        |
| s%_tcp_mss=512            | (number)                                                                                        |
| s%_tcp_ttl=64             | (number)                                                                                        |
| s%_tcp_setport=random     | (random   fixed)                                                                                |
| s%_tcp_nagle=disable      | (disable   enable)                                                                              |
| s%_tcp_keepalive=no       | (yes   no)                                                                                      |
| s%_tcp_keepaliveval=120   | (number)                                                                                        |
| s%_telnet_break=          | (none   break   IP   AO)                                                                        |
| s%_telnet_naws=yes        | (yes   no)                                                                                      |
| s%_initstring=            | (character string, 8 char max.)                                                                 |
| s%_answerback=            | (character string, 10 char max.)                                                                |
| s%_screen_overscan=09     | (no   number in range 0 to 63)                                                                  |
| s%_screen_codepage=437    | (437   850   860   8859   8859-sg<br>dec-multi   iso-7   sm9400<br>ato300   greek   861   857 ) |
| s%_screen_column=80       | (80   132)                                                                                      |
| s%_screen_line=25         | (25   24+1)                                                                                     |
| s%_screen_scroll=yes      | (yes   no)                                                                                      |
| s%_screen_wrap=yes        | (yes   no)                                                                                      |
| s%_screen_crlf=yes        | (yes   no)                                                                                      |
| s%_screen_cursor=block    | (line   half-block   block)                                                                     |
| s%_screen_enhanced=no     | (no   doublesize   underline)                                                                   |
| s%_screen_attbmode=       | (black-white   color)                                                                           |
| s%_ignore_blank=no        | (yes   no)                                                                                      |
| s%_kbd_code=scancode      | (ascii   scancode)                                                                              |
| s%_kbd_capsmode=caps-lock | (caps-lock   shift-lock  <br>uppercase)                                                         |
| s%_kbd_localcompose=no    | (no   remote   local)                                                                           |
| s%_kbd_special            | (yes   no)                                                                                      |
| s%_eurocode=              | (no   euro ASCII code)                                                                          |

```
s%_blink_enable= (yes | no)
s%_fctn_monitor=no (no | symbol-mode | hexa-mode)
s%_fctn_termprg=no (yes | no)
s%_nulls_suppress=no (yes | no)
s%_fctn_endprn=\lB[4i (character string, 6 char max.)
s%_fctn_colsep=yes (yes | no)
s%_fctn_rule-style= (horizontal | vertical | cross)
s%_fctn_rule-move= (yes | no)
s%_fctn_localwin=yes (yes | no)
s%_fctn_transp= (yes | yes-hexa)
s%_fctn_transp-seq= (character string, 4 char max.)
s%_fctn_typeahead=yes (yes | no)
s%_mouse_enable=yes (yes | no)
s%_remote_cad=yes (yes | no)
s%_ScrlLockPause=enabled (enabled | disabled)
s%_vnc_enpassword= (character string, 16 char max.)
s%_vnc_password= (character string, 16 char max.)
s%_vnc_prefencod= (zrle | hextile)
s%_vnc_cachehextile= (yes | no)
s%_vnc_doublescreen= (no | left | right)
s%_vnc_shared=no (yes | no)
s%_vnc_noinput=no (yes | no)
s%_vnc_localmouse=yes (yes | no)
s%_vnc_emulbutton=yes (yes | no)
s%_vnc_msesensitivity=medium (low | medium | high)
s%_vnc_mouseaccel=yes (yes | no)
s%_vnc_numpad=standard (standard | ascii)
s%_vnc_AltGr= (standard | ctrl+alt)
s%_rdp_username= (character string, 64 char max.)
s%_rdp_autologon=no (yes | no)
#s%_rdp_enpassword= (character string, 48 char max.)
#s%_rdp_password= (character string, 16 char max.)
s%_rdp_domain= (character string, 64 char max.)
s%_rdp_autorun=no (yes | no)
s%_rdp_progname= (character string, 128 char max.)
s%_rdp_pathname= (character string, 128 char max.)
s%_rdp_encryption= (low | medium | high | no)
s%_rdp_connectionname= (character string, 20 char max.)
s%_rdp_mouseaccel=no (yes | no)
```

|                              |                                                        |
|------------------------------|--------------------------------------------------------|
| s%_rdp_cachebitmap=yes       | (yes   no)                                             |
| s%_rdp_compression=yes       | (yes   no   screen  <br>screen+printer)                |
| s%_rdp_prnredir=all          | (none   all   xxx)                                     |
| s%_rdp_prndef=no             | (no   xxx)                                             |
| s%_rdp_comredir=all          | (none   all   xxx)                                     |
| s%_rdp_usbdriveredir=        | (yes   no)                                             |
| s%_rdp_scaredir=             | (yes   no)                                             |
| s%_rdp_scardauto=            | (yes   no)                                             |
| s%_rdp_soundredir=yes        | (yes   no)                                             |
| s%_rdp_soundquality=high     | (low   medium   high)                                  |
| s%_rdp_msesensitivity=medium | (low   medium   high   maximal)                        |
| s%_rdp_msereport=            | (all   click)                                          |
| s%_rdp_bckg=                 | (disabled  enabled)                                    |
| s%_rdp_wincontent=           | (disabled  enabled)                                    |
| s%_rdp_animation=            | (disabled  enabled)                                    |
| s%_rdp_theme=                | (disabled  enabled)                                    |
| s%_dsk_nbssession=           | (numeric)                                              |
| s%_dsklabel_applic=          | (character string, 60 char max.)                       |
| s%_dsklabel_close=           | (character string, 60 char max.)                       |
| s%_ica_target=               | (local server   ICA server  <br>published application) |
| s%_ica_icasrv=               | (character string, 64 char max.)                       |
| s%_ica_published=            | (character string, 64 char max.)                       |
| s%_ica_protobr=              | (TCP/IP + HTTP   TCP/IP)                               |
| s%_ica_portbr=               | (1604   numeric)                                       |
| s%_ica_masterbr=             | (broadcast   IP   Name)                                |
| s%_ica_brtrace=no            | (yes   no)                                             |
| s%_ica_braltip=no            | (yes   no)                                             |
| s%_ica_username=             | (character string, 64 char max.)                       |
| s%_ica_autologon=no          | (yes   no)                                             |
| #s%_ica_enpassword=          | (character string, 48 char max.)                       |
| #s%_ica_password=            | (character string, 16 char max.)                       |
| s%_ica_domain=               | (character string, 64 char max.)                       |
| s%_ica_autorun=no            | (yes   no)                                             |
| s%_ica_progname=             | (character string, 128 char max.)                      |
| s%_ica_pathname=             | (character string, 128 char max.)                      |
| s%_ica_encryption=           | (basic)                                                |
| s%_ica_connectionname=       | (character string, 20 char max.)                       |

|                               |                                                                                                 |
|-------------------------------|-------------------------------------------------------------------------------------------------|
| s%_ica_mouseaccel=no          | (yes   no)                                                                                      |
| s%_ica_compression=yes        | (yes   no)                                                                                      |
| s%_ica_msesensitivity=high    | (low   medium   high   maximal)                                                                 |
| s%_ica_msereport=all          | (all   click)                                                                                   |
| s%_ica_prnredir=all           | (none   all   xxx)                                                                              |
| s%_ica_prndef=no              | (no   xxx)                                                                                      |
| s%_ica_comredir=all           | (none   all   xxx)                                                                              |
| s%_ica_usbdriveredir=         | (yes   no)                                                                                      |
| s%_ica_scaredir=              | (yes   no)                                                                                      |
| s%_ica_scardauto=             | (yes   no)                                                                                      |
| s%_vdk_masterbr=192.168.1.167 | (IP   Name)                                                                                     |
| s%_vdk_portbr=80              | (number)                                                                                        |
| s%_vdk_username=              | (character string, 64 char max.)                                                                |
| s%_vdk_autologon=no           | (yes   no)                                                                                      |
| #s%_vdk_enpassword=           | (character string, 48 char max.)                                                                |
| s%_vdk_password=              | (character string, 16 char max.)                                                                |
| s%_vdk_domain=                | (character string, 64 char max.)                                                                |
| s%_vdk_encryption=basic       | (no   low   medium   high  <br>basic   RC5 (128 logon)  <br>RC5 (40)   RC5 (56)  <br>RC5 (128)) |
| s%_vdk_connectionname=        | (character string, 20 char max.)                                                                |
| s%_vdk_remotectl=no           | (yes   no)                                                                                      |
| s%_vdk_remotecad=yes          | (yes   no)                                                                                      |
| s%_vdk_prnredir=all           | (none   all   xxx)                                                                              |
| s%_vdk_prndef=no              | (yes   no)                                                                                      |
| s%_vdk_comredir=all           | (none   all   xxx)                                                                              |
| s%_vdk_usbdriveredir=no       | (yes   no)                                                                                      |
| S%_vdk_scaredir=no            | (yes   no)                                                                                      |
| s%_vdk_scardauto=no           | (yes   no)                                                                                      |
| s%_ica_soundredir=yes         | (yes   no)                                                                                      |
| s%_ica_soundquality=high      | (low   medium   high)                                                                           |
| s%_vdk_cachebitmap=no         | (yes   no)                                                                                      |
| s%_vdk_compression=yes        | (yes   no)                                                                                      |
| s%_vdk_msereport=all          | (all   click)                                                                                   |
| s%_vdk_msesensitivity=high    | (low   medium   high   maximal)                                                                 |
| s%_vdk_bckg=                  | (yes   no)                                                                                      |
| s%_vdk_wincontent=            | (yes   no)                                                                                      |
| s%_vdk_animation=             | (yes   no)                                                                                      |

```

s%_vdk_theme=                (yes | no)
s%_color_mode=yes            (yes | no | enhanced)
s%_normal_foregrnd=lt-green  (16-color format)
s%_normal_backgrnd=black     (8-color format)
s%_reverse_foregrnd=lt-red   (16-color format)
s%_reverse_backgrnd=white    (8-color format)
s%_underscore_foregrnd=yellow (16-color format)
s%_underscore_backgrnd=black (8-color format)
s%_graphics_foregrnd=hi-white (16-color format)
s%_graphics_backgrnd=magenta (8-color format)
#s%_enhanced_foregrndxxx=white (16-color format)
#s%_enhanced_backgrndxxx=blue (16-color format)
#s%_enhanced_blinkxxx=no     (yes | no)
#s%_enhanced_underlxxx=no    (yes | no)
s%_palette%=                 (number from de 0 to 63)
s%_black=                    (number from de 0 to 63)
s%_grey=                     (number from de 0 to 63)
s%_white=                    (number from de 0 to 63)
s%_tab=      X              X              X              X              X              X              X
                                                    (char string, 132 max., X=tabu.)
s%_udk_f%=                   (character string, 32 char max.)
s%_udk_ins=                   (character string, 32 char max.)
s%_udk_end=                   (character string, 32 char max.)
s%_udk_dn=                    (character string, 32 char max.)
s%_udk_pgdn=                  (character string, 32 char max.)
s%_udk_left=                  (character string, 32 char max.)
s%_udk_five=                  (character string, 32 char max.)
s%_udk_right=                 (character string, 32 char max.)
s%_udk_home=                  (character string, 32 char max.)
s%_udk_up=                    (character string, 32 char max.)
s%_udk_pgup=                  (character string, 32 char max.)
s%_udk_minus=                 (character string, 32 char max.)
s%_udk_plus=                  (character string, 32 char max.)
s%_udk_del=                   (character string, 32 char max.)
s%_udk_esc=                   (character string, 32 char max.)
s%_udk_dot=                   (. | ,)
s%_udk_backspace=            (\08 | \7F | ansi | sm9400)
s%_idk_backspace=Standard    (Standard | backspace)
s%_seq_modifier%=           (alt | shift | control)

```

s%\_seq\_scan%= (character string, 20 char max.)  
s%\_seq\_string%= (character string, 256 char max.)  
s%\_seq\_cmd% (5250 functions)

**Notes:**

- The "s%\_predefined\_setup" parameter automatically sets all the session parameters with proper values.
- When the configuration file is obtained from an already configured AX3000, non significant parameters are commented out.

**End of File**

The configuration file must be ended with the following trailer label:

```
END_AX_SETUP
```

If this trailer label is missing, from the configuration file used to set-up an AX3000, the fatal error message `ERR 103` will be issued in response to the `rsh` command and the default factory set-up will be reloaded.

## **A.6 - SETTING-UP AXEL DHCP OPTIONS**

In addition to the standard options (IP addresses, DNS server...), the DHCP server can be used to communicate manufacturer specific information: this allows to set "**Axel DHCP options**".

For example, Axel's auto-configuration feature (see chapter 2.1) requires the terminal to know the network location of the machine running the management tool (AxRM). This information can be given to terminals using this DHCP feature.

### **A.6.1 - Overview**

A DHCP server has various options numbered as follows:

- From 1 to 223: reserved options. For example, option 3 gives the list of routers and 15 lists DNS servers.
- From 224 to 254: private options. Available for manufacturers use.

The Axel options are contained within the range of numbers from 231 to 240. The 'type' is always 'character string'. The format of the entry is as follows:

- Entry starts with a keyword followed by one or more parameters.
- The symbol ":" is used as separator.

☺: In contrast to some implementations Axel uses a 'keyword' rather than a specific number. The actual number (231 to 240) is irrelevant so any non-conflicting number in this range can be used.

For more information on the Axel options see chapter A.6.3.

### **A.6.2 - Adding an Axel option with the Microsoft DHCP Server**

To add an Axel DHCP option with Microsoft's DHCP server see below:

1 - Launch the DHCP utility.

Right click on the IP address of the DHCP server and select 'Set Predefined Options' and select 'Add'

2 - The following dialog box is displayed:

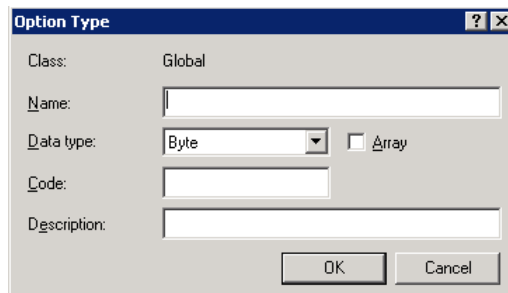

Complete the fields as follows:

- Name = (User definable) for example 'Axel Autoconf'
- Data Type = (mandatory) string
- Code = (User definable) select unused number between 231 and 240
- Description = (User definable) for example "Axel vender option for auto-configuration".

Click 'OK' to exit this box and 'OK' again to exit the former box.

3 - In the left panel select 'Server Options' then right click 'Configure Options' Within the available options 'tick' the new Axel entry and enter IP and TCP port details as below as 'string value'. For example:

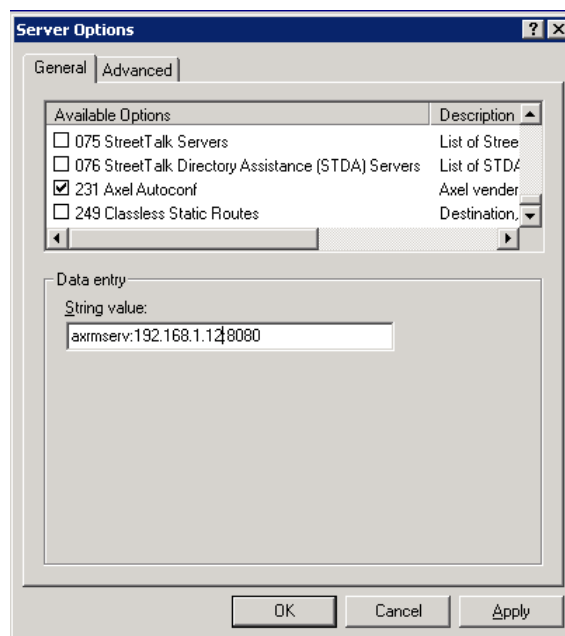

**Note:** the changes take immediately effect.

### **A.6.3 - 'axrmserv' option: auto-configuration**

The axrmserv option always the network location of the AxRM server to be broadcast.

The format is as follows:

```
axrmserv:param1:param2
```



The parameters are:

- The IP address or DNS name of the AxRM server
- The TCP port AxRM is listening on

Having two parameters is not mandatory nor is the order important. For example you may only need to enter the IP address if the default port 80 is being used.

The table below gives examples:

|                        | AxRM Network Location                                                |          |
|------------------------|----------------------------------------------------------------------|----------|
|                        | IP address                                                           | TCP port |
| axrmserver:mypc:82     | "mypc" DNS resolution                                                | 82       |
| axrmserver:82          | The IP address will be given by the method 2 or 3 (see chapter 2.1). | 82       |
| axrmserver:192.168.0.1 | 192.168.0.1                                                          | 80       |

## A.7 - SETTING THE IP ADDRESS BY A PING COMMAND

A new feature with version 'e' firmware enables the system manager to remotely assign an initial IP address to a brand new terminal, or remotely change an existing IP address.

The procedure is to manually modify the ARP table of your computer (Unix, Linux, Windows...). An ARP table entry is composed of IP addresses and Ethernet MAC addresses. The command below associates an arbitrary IP address to the terminal's hard coded MAC address. The MAC address is printed on the base of each terminal. With its updated ARP table your computer is able to access the AX3000. To set the new IP address the terminal must be pinged a multiple times.

**Using under Unix/Linux:**

Run the following command to associate the AX3000's Ethernet address xx:xx:xx:xx:xx:xx with the IP address a.b.c.d (this command updates the ARP table):

```
# arp -s a.b.c.d xx:xx:xx:xx:xx:xx
```

Run a ping command:

```
$ ping a.b.c.d
```

The first ping requests are not acknowledged. But after few seconds the AX3000 is rebooted and replies the ping requests. The AX3000 is now set with the a.b.c.d IP address.

**Using under Windows:**

☺: Windows administration s/w (AxRM or Axel Remote Management) is available free on the Axel Web site. See Chapter 8.8.2.

The procedure is the same as Unix/Linux except for the Ethernet address notation ('-' are used as separators instead of ':'). The command is:

```
C:\> arp -s a.b.c.d xx-xx-xx-xx-xx-xx
```

Run one or more ping commands (4 ping requests are sent by ping command):

```
C:\> ping a.b.c.d
```

**Note:** if required this function can be disabled by setting the 'IP Addr. Set by Ping' parameter to 'no'. For more information, refer to Appendix A.10.6.

**A.8 - RSH ADMINISTRATION COMMAND LIST**

Several administration commands are offered by the AX3000. These commands are launched by using a remote administration command (**rsh** for example) which is available as standard features from most major operating systems.

The following table lists the available AX3000 administration commands:

| Command     | Description                                                                                                                             |
|-------------|-----------------------------------------------------------------------------------------------------------------------------------------|
| ax_reboot   | Rebooting the AX3000.<br>Example: rsh ax3000 ax_reboot [password]<br>More information: chapter 10.4                                     |
| ax_sinit    | Resetting an AX3000 resource (screen session or aux. port)<br>Example: rsh ax3000 ax_sinit [password] sess1                             |
| setup_get   | Requesting the AX3000 Set-Up.<br>Example: rsh ax3000 setup_get > file<br>More information: chapter 10.4                                 |
| setup_send  | Setting-up the AX3000 through a text file.<br>Example: rsh ax3000 setup_send [password] < file<br>More information: chapter 10.4        |
| ax_download | Requesting an AX3000 firmware downloading.<br>Example: rsh ax3000 ax_download [password] 192.1.1.1 file<br>More information: chapter 11 |
| ax_version  | Requesting the AX3000 firmware revision.<br>Example: rsh ax3000 ax_version                                                              |
| ax_getstat  | Requesting the AX3000 statistics.<br>Example: rsh ax3000 ax_getstat<br>More information: chapter 9.3                                    |

**Note:** these commands are also available with uppercase characters (ax\_version and AX\_VERSION are the same command).

## A.9 - FIRMWARE DOWNLOADING (BOOTP AND TFTP)

Firmware can be downloaded, for example to add or improve AX3000 features.

**Note:** this chapter is dedicated to experts and dealt only with TFTP and BOOTP protocols. Generally a firmware downloaded via a free Windows administration utility (AxRM or Axel Remote Management). See Chapter 10.1.

Firmware can be downloaded in one of two ways:

- **tftp** protocol: the operator must enter the location of the firmware file.

- **bootp and tftp** protocol: this is an automatic procedure. The necessary parameters will already be available from a bootp server.

Whichever method is used, the firmware file is downloaded from a host (called the tftp host). Following this the AX3000 is automatically reset and the new firmware is enabled.

These two methods can be run either:

- Using the remote administration command from any network host or
- Through the set-up of the AX3000 that is to be upgraded.

All Axel products have an 'FK' (Firmware key) number. **It is important that the firmware file and Axel hardware have the same FK number.** If not the update will fail. For more information, refer to Appendix A.11.

#### **A.9.1 - Declaring and Enabling TFTP and BOOTP**

##### ***a) Unix***

These two protocols are included but not normally enabled by default.

To enable perform the following:

- Modify the file **/etc/inetd.conf** by removing the '#' comment character, from the beginning of the line(s) associated with **tftp** and/or **bootps**  
**Note:** for tftp, take care to use the 'public' mode (within inetd.conf, the 'user' field must be 'nouser' or 'nobody' and the tftpd daemon **must be launched without** the '-s /tftpboot' parameter).
- Reboot the UNIX host (or send the signal 1 to the `inetd` process).

Examples of TFTP declarations:

##### **SCO OpenServer**

```
tftp dgram udp wait nouser /etc/tftpd tftpd
```

##### **AIX 4.x**

```
tftp dgram udp nowait nobody /usr/sbin/tftpd tftpd -n
```

**UNIXWARE 7**

```
tftp dgram udp wait nobody /usr/sbin/in.tftpd in.tftpd
```

**b) Linux**

First, check the tftp package is already installed. The tftp protocol works through the xinetd daemon. Check if xinetd is running. If not, enable xinetd.

A file **'tftp'** should be present in **/etc/xinetd.d**. This file contains the tftp server settings. Check the content of the file is as shown below:

```
service tftp
{
    socket_type          = dgram
    protocol             = udp
    wait                = yes
    user                 = root
    server               = /usr/sbin/in.tftpd
    server_args         = /
    disable             = no
}
```

Reboot if you modified any of these settings.

**c) OS/400**

The TFTP protocol is available as a standard feature on OS/400, but must be correctly set to match with the AX3000 requirements.

**1 - Create a directory**

```
====> CRTDIR DIR('axfirm')
```

**2 - Copy the firmware file (for example ax3000) on /axfirm.**

**3 - Change the directory "/axfirm" QTFTP user's rights:**

```
====> CHGAUT OBJ('/axfirm') USER(QTFTP) DTAAUT(*RX) OBJAUT(*NONE)
```

**4 - Change the file "/axfirm/ax3000" QFTFTP user's rights:**

```
===> CHGAUT OBJ('/axfirm/ax3000') USER(QFTFTP) DTAAUT(*RX) OBJAUT(*NONE)
```

**5 - User's right can be checked by invoking:**

```
===> WRKLNK OBJ('/axfirm')
===> WRKLNK OBJ('/axfirm/ax3000')
```

**6 - Change the default TFTP directory:**

```
===> CHGTFTPA ALTSRCDIR('/axfirm')
```

**7 - Stop and restart the TFTP server**

```
===> ENDTCPSVR(*TFTP)
===> STRTCPSVR(*TFTP)
```

Then download the firmware from the AX3000 interactive set-up (see next chapter).

**A.9.2 - Downloading by TFTP Protocol**

To download firmware using the tftp protocol, the firmware file location (filename and tftp host IP address) must be given.

***a) Remote Administration***

The remote administration command depends on the operating system. Refer to the Chapter 6.4 (OS/400), the Chapter 7.3 (OS/390) or the Chapter 8.5 (Unix/Linux).

Example for Unix/Linux:

```
# rsh ax3001 ax_download password /usr/firm 192.168.1.249
```

The message 'Download in progress...' is displayed on the operator's console if the download runs correctly.

Possible errors (displayed on the operator's console):

```
-ERR 105: invalid rcmd command: incorrect keyword (check the
syntax and spelling).
```

- ERR 108: invalid number of parameters: bad parameter number (2 or 3 parameters are required after the keyword).
- ERR 109: invalid file length: the filename is too long (more than 31 characters).
- ERR 110: invalid server: the tftp host name is unknown (not listed in the AX3000 set-up).
- ERR 111: invalid router: the router name is unknown (not listed in the AX3000 set-up).

**Note:** other error messages may also be displayed (connection timed-out, for example). Refer to the UNIX system manuals for explanations.

For more information about the download process, see Chapter A.9.4.

### ***b) Downloading Through Set-Up***

Enter AX3000 Set-Up (<Ctrl><Alt><Esc>) and select the **[Download]** menu. The following dialog box is displayed:

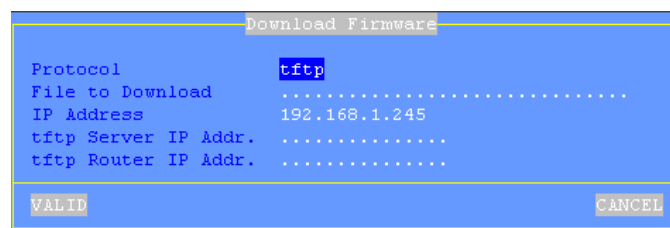

Enter the following parameters:

- **Protocol:** select tftp,
- **Filename:** path and name of the firmware file, back-slashes for this character string must be doubled. For example: C:\\AXEL\\FIRM.
- **AX3000 IP:** this is an IP address only used during the downloading operation. It can differ from the current IP address,
- **tftp Host IP:** name or IP address of the tftp host,
- **tftp Router IP** (optional): name or IP address of a router via which the tftp host can be reached.

When the [OK] button is selected, the download operation begins.

For more information about the download process see Chapter A.9.4.

### **A.9.3 - Downloading by BOOTP and TFTP Protocols**

This procedure is divided into 2 steps:

- bootp: obtaining firmware file information,
- tftp: downloading firmware file.

The bootp protocol is used get the location (IP address of the tftp host and filename) of the firmware file. This information is obtained by means of a broadcast.

Information concerning this firmware file must have been configured within the bootp host.

Prerequisites for `bootp`:

- The `bootpd` process must be run on the bootp host.
- The `bootpd` configuration file (**`/etc/bootptab`**) must list an entry for every AX3000 which can download firmware.
- The bootp host must be directly accessed by the AX3000 (not via a router). Otherwise, a bootp relay host must be set up.

The main capabilities of the `bootpd` configuration file are as follows:

- `tc`: network description
- `ht`: network type
- `sa`: IP address of tftp host
- `gw`: optional router
- `ha`: Ethernet address of the AX3000
- `ip`: IP address of the AX3000 (this address is only used during the downloading operation)
- `bf`: full firmware file name (path included)



**Examples of bootp configuration files:**

a) When the AX3000 and the tftp host are on the same network

```
net:hn:df=/etc/btdump:ht=ethernet:sa=192.168.1.252:to=auto:
axell:tc=net:ht=ethernet:ha=00A034000001:ip=192.168.1.242:bf=/tmp/axel:
```

b) When the AX3000 accesses the tftp host via a router

```
net:hn:df=/etc/btdump:ht=ethernet:sa=192.1.1.243:to=auto:
net1:tc=net:sm=255.255.255.000:gw=192.168.1.252:
axell:tc=net1:ht=ethernet:vm=rfc1048:ha=00A034000001:ip=192.168.1.242:bf=
/usr/axel/firm9645:
```

**IMPORTANT:** if a problem occurred during a previous download operation (whatever method was used), the firmware of the target AX3000 may have been erased. To restore valid firmware, the bootp+tftp protocol will automatically be run when this target AX3000 is switched on.

**a) Remote Administration**

The remote administration command depends on the operating system. Refer to the Chapter 5.5 (Unix/Linux), the Chapter 6.4 (OS/400) or the Chapter 7.3 (OS/390).

Example for Unix/Linux:

```
# rsh ax3001 ax_download password
```

The message 'Download in progress...' will be displayed on the operator's console if downloading can be performed (AX3000 and tftp host reachable, firmware file found, etc).

**Note:** error messages can also be displayed (connection timed-out for example). For explanations refer to UNIX manuals.

For more information about the download process, see Chapter A.9.4

**b) Downloading Through Set-Up**

Enter AX3000 Set-Up (<Ctrl><Alt><Esc>) and select the **[Download]** menu. Set the **Protocol** parameter to **bootp**. When the [OK] button is selected, the download operation begins.

For more information about the download process, see Chapter A.9.4.

**A.9.4 - The Download Process**

During the download operation, the following messages are displayed on the AX3000 monitor.

**a) The bootp Stage**

```
AX BOOTP V1.1a
Flash Key 3
```

If a response is received to the bootp broadcast request, information about the firmware file location will be displayed:

```
AX3000 IP: 192.168.1.242
bootp server name: vangogh
bootp relay IP: 0.0.0.0
tftp server IP: 192.1.1.254
file name: /axel/firm
tftp router IP: 192.168.1.252
```

```
AX BOOTP V1.1a
Flash Key 3
```

Next, an automatic connection to the tftp host will then be made, in order to download the firmware file.

**b) The tftp Stage**

```
AX TFTP V1.1a
Flash Key 3
```

If the download can be performed, the current firmware is erased and the following message is displayed on the AX3000 monitor:

```
Erasing code...
```

Then, the selected firmware file is downloaded (each dot represents 512 bytes):

```
Loading code
.....
.....
.....
.....
.....
code loaded
```

Finally, the AX3000 is automatically reset and the new firmware is enabled.

**IMPORTANT:** The AX3000 IP layer, used for the tftp protocol, does not handle the fragmentation/defragmentation process. Therefore, if a router fragments frames (mtu lower than 600 bytes), the AX3000 will not be able to perform the download.

#### **A.9.5 - In Event of difficulties**

This section describes possible problems. The error list is not exhaustive. If an unlisted error occurs, please contact your AXEL distributor.

After an error, the AX3000 should be power-cycled.

##### ***a) The bootp Stage***

If an error occurs, the following message is displayed on the AX3000 monitor:

```
Bootp errno: xxx
```

- xxx is the error number.

Possible errors:

- 0: Ethernet board not responding.
- 1: no response to the bootp broadcast request (the bootp host is unreachable or not correctly set-up).

**b) The tftp Stage**

A tftp error message can originate from either the tftp host or the AX3000.

Depending on the error, the AX3000 firmware may be erased. If this happens the firmware code will be automatically downloaded (bootp+tftp protocol) the next time the AX3000 is power-cycled.

**Tftp Host Errors:**

```
tftp errno: xxx label
```

- `xxx` is the error number,
- `label` is the error message. This label is sent by the tftp host and is generated by UNIX running on the tftp host.

Possible errors:

- 1: File not found
- 2: Access violation
- 3: Disk full or allocation exceeded
- 4: Illegal TFTP operation
- 5: Unknown transaction Identifier
- 6: File already exists
- 7: Illegal TFTP operation
- 0: User-defined error

For more information, refer to UNIX manuals.

**Tftp AX3000 Errors:**

```
tftp errno: xxx
```

- `xxx` is the error number.

Possible errors:

- 10: Ethernet board not responding.
- 11: no response to the tftp broadcast request (the tftp host is unreachable or not correctly set-up).
- 12: network error.
- 13: the firmware file does not correspond to AX3000 firmware or is not compatible with the AX3000 model.

- 14: the firmware file size is less than 256 bytes. This indicates that the file is not an AX3000 firmware file.
- 15: checksum error on the firmware file.

#### **AX3000 Flash Memory Errors:**

```
flash errno: xxx
```

- xxx is the error number.

Possible errors:

- 0: flash erasing failure
- 1: flash programming failure
- 2: checksum error (invalid firmware file)
- 3: segment descriptor programming failure

## **A.10 - MORE INFORMATION...**

### **A.10.1 - Reload Factory Settings**

The menu **[Configuration]-[Advanced]-[Factory Settings]** allows, after confirmation, terminal factory settings to be reloaded. **The current configuration is lost.**

On next boot, the Quick Set-Up will be displayed and the Auto-Configuration service will be started (see Chapter 2).

### **A.10.2 - General Level: Advanced Parameters**

This chapter describes special AX3000 operating parameters. Usually the default values are suitable.

All these general parameters are located in a specific dialog box in menu **[Configuration]-[Advanced]-[Tuning]**:

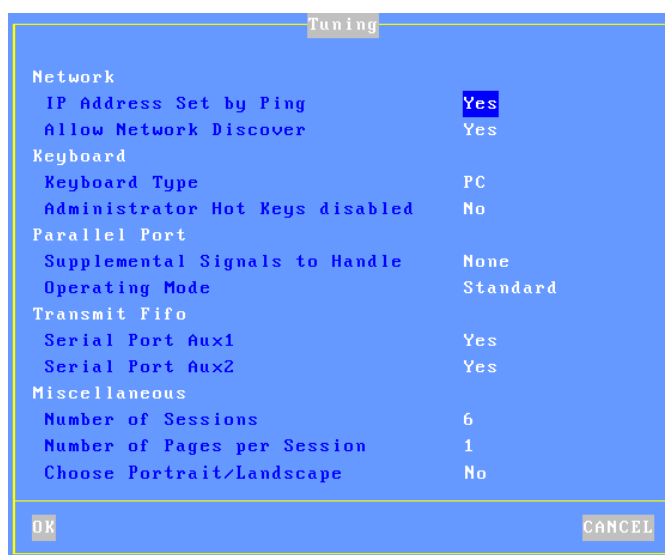

**a) The 'IP Addr. Set by Ping' Parameter**

This parameter allows or disables the AX3000 IP Address to be set by a ping command. (See Appendix A.7.)

**Note:** a new value takes immediately effect.

**b) The 'Allow Network Discover' Parameter**

By default, SNMP requests are supported by Axel terminals. This allows terminals to be discovered by AxRM (the Axel administration software).

This parameter can be used to disabled the SNMP support.

**Note:** changing this value takes immediately effect.

**c) The 'Keyboard Type' Parameter**

By default PC keyboards (102/105 keys) are supported by the AX3000, but other

keyboards type are available for special use:

- AS400 (F24): 122-keys keyboard (24 function keys) for 5250 emulation,
- ANSI (F20): keyboard with 20 function keys for VT220 emulation.

**Note:** this keyboard type modification takes immediately effect.

Note: Do not experiment with keyboard types – i.e. if you do not have an AS400 keyboard do not select AS400

#### ***d) The 'Screen Type' Parameter***

**Note:** this parameter is only available with the firmware TXT option.

By default the Screen Type is set to TFT. A CRT type can be selected. It's used only for displaying text-base session in 132-column mode.

#### ***e) The 'Frequency' Parameter***

By default the Frequency is set to 60Hz. An alternate value is available: 75Hz.

#### ***f) The 'Administrator Hot-Keys disabled' Parameter***

This parameter allows certain AX3000 hot-keys to be disabled, possibly useful if the terminal is installed in public places. For example, this prevents a user from invoking <Ctrl><Alt><Del> function. For more information, see Chapter 4.6.

**Note:** when this parameter is set to 'yes', the "consultation mode" and the "super password" don't allow the set-up to be entered.

#### ***g) The 'Supplemental Signals to Handle' Parameter***

The AX3000 checks the printer status by reading both the "Busy" and "Select-In" signals before printing.

The AX3000 will not transmit data for printing if the printer handles only the "Busy" signal,

This parameter determines whether the "Select-In" and/or "Paper Empty" signals will be selected in addition to the "Busy" signal (which is always used).

**Note:** the signal modification takes immediately effect.

***h) The 'Operating Mode' Parameter***

Data is usually sent to the parallel port through a method based on 'interrupts'. This makes efficient use of the AX3000 CPU.

In event of problems (no printing or a very slow printing), it is possible to change this parallel port management and to send data by a 'polling' method. To enable this method, set the "Operating Mode" parameter to "Standard".

**Note:** the parallel port management modification takes immediately effect.

***i) The 'Transmit FIFO, AUX1 and AUX2 ports' Parameter***

The AUX1 and AUX2 ports provide an embedded transmit buffer (FIFO). This allows the data transmission to be optimized. By default this mechanism is enabled.

If necessary this parameter allows the AUX1 (or AUX2) FIFO buffer to be disabled.

**Note:** the FIFO modification takes immediately effect.

***j) The 'Number of Sessions' Parameter***

This parameter is the maximum number of concurrent connections. Its value is from 1 to 6.

***k) The 'Number of Pages per Session' Parameter***

This parameter allows multi-page support. This may be used by legacy text application under Unix/Linux.

**Important:** the 'Number of Sessions' multiplied per the "Number of Pages per Session" must not exceed 6.

***l) The 'Choose Portrait/Landscape' Parameter***

When this option is set, printer string sequences can be entered for the "default



printer port" and printer services (LPD, Prt3270...). These sequences allow a portrait/landscape mode to be selected via a terminal status line icon (see Chapter 4.1.2).

### **A.10.3 - Session Level: Enhanced Parameters**

Each session (screen or auxiliary port) offers enhanced parameters. These parameters are available through the "Connection Properties" box (depending on the session type this box is located in the **[Sessions]-[Session x]** menu or the **[Aux. Ports]-[xxx]** menu).

This is an example of the dialog box:



#### **Notes:**

- The available parameters depend on both the connection type (screen or auxiliary port) and the associated protocol.
- New values are used for the next TCP/IP connection (no need to power-cycle the AX3000).

#### **a) The 'Secondary Server' Parameter**

A secondary server allows the user to select on which server the session is connected to. The server is chosen when the session is established. A mini-

menu is displayed.

**b) The 'TCP port' Parameter**

This parameter is the server TCP port on which the session is connected. The default values are 23 for telnet, 2048 for tty, 3389 for RDP and 1494 for ICA.

**c) The 'mss' and 'Window' Parameters**

These two parameters are the AX3000 resources allocated to telnet and tty screen sessions for receiving network data:

- **mss** (maximum segment size) is the largest segment of TCP data. This size is negotiated with the server at the connection time.
- **window** is the reception windows size (i.e. the size of the buffer on which the TCP data is stored).

It is not advisable to modify these two values unless the input data flow is not continuous (i.e. the data flow pauses and resumes regularly during scrolling).

**d) The 'Time to Live' Parameter**

This parameter controls the 'to live' time of the datagram to prevent it being looped forever due to routing errors. Routers decrement the TTL of every datagram as it traverses from one network to another. When its value reaches 0 the packet is dropped.

This parameter doesn't impact the AX3000 performance.

**e) The 'TCP port Assignment' Parameter**

The AX3000 resources (screen sessions and auxiliary ports) are identified by numeric values called TCP ports.

The TCP port assignment can be either random or fixed. The default value depends on the current network service.

The random method means the AX3000 TCP ports are different after every reboot. On booting the AX3000 generates a new base value. This value (x) is between 1024 and 3072. For each session a range of 8 TCP ports is given: session 1 = (x...x+7), session 2 = (x+8...x+15)... When a connection is established the next port of the associated range is used. After 8 connections, the same TCP port of a range is re-used.

The main benefit of this method is that if the AX3000 is suddenly powered off (power cut for example), at the next boot time, the connections are immediately accepted by the server. (i.e. the sessions are hooked on different sockets because the TCP ports are different). However this does create 'phantom' sessions, as the initial sessions are still active from the server's perspective, and must be killed by the server.

This can be done with the 'keepalive' process, manually killing or rebooting.

In some situations it may be beneficial to have always the same TCP port for an AX3000 resource (to avoid phantom sessions or to identify connections). This is the fixed port assignment. With this method the AX3000 resources are always:

- session 1 = 1024, ..., session 8 = 1031,
- aux1 port = 1032, aux2 port = 1033, parallel port 1034.
- net1 = 1035, net2 = 1036,
- usb1 = 1037, ... ,usb4 = 1040

#### ***f) The 'Nagle's Algorithm' Parameter***

The Nagle's Algorithm controls behavior of the output network dataflow of a TCP/IP device. This algorithm allows the number of datagrams sent by the AX3000 to decrease. However a certain latency may be noticeable due to the caching of data before transmission.

This algorithm is disabled to prioritize performance. However some operating systems require this function to be enabled.

#### ***g) The 'Keepalive' Parameter***

The keepalive is a mechanism that allows the AX3000 to regularly check its TCP/IP connection status.

In event of network incident, the AX3000 is able to detect this incident and to close the related TCP/IP connections. This mechanism is also useful when DSL connections are used (the AX3000 IP address is reset on time per day).

By default the keepalive function is disabled.

The keepalive function is set in minutes

**Note:** with ISDN routers (which automatically drop the phone line) this regular data flow will prevent the router from hanging-up. In this scenario the keepalive

can cause expensive phone bills.

#### ***h) The 'Break Code' Parameter***

For the telnet session, the **<Ctrl><Alt><Pause>** hotkey sends a 'break' code to the host. This break code is defined by the RFC 854, this is 'IAC BREAK'.

If needed, this break code value can be modified. The extra values are:

- AO (Abort Output),
- IP (Interrupt process),
- None (<Ctrl><Alt><Pause> generates no code).

#### ***i) The 'Enabling NAWS' Parameter***

The NAWS function (Negotiate About Window Size - RFC 1073) is an optional feature negotiated when the telnet session established. It allows the terminal screen format (line x row) to be indicated to the server (when the session is established or at any time when the screen format is modified).

This parameter allows this function to be disabled: some telnet servers don't correctly support the NAWS function.

#### ***j) The 'Always add NULL after CR' Parameter***

This option allows to be compliant with different telnet server implementation (about ASCII mode).

#### ***j) The 'National Language Negotiation' Parameter***

This option is only available with 5250 emulation. It allows some environment variables (KBDTYPE, CODEPAGE and CHARSET) to be set.

### **A.10.4 - RDP/ICA Sessions: Microsoft Keyboard Codes**

For RDP/ICA sessions a Microsoft keyboard code can be specified. This code allows a keyboard nationality to be negotiated with the TSE server.

The following table lists the available keyboard codes:

| Keyboard Nationality | Code | Keyboard Nationality | Code |
|----------------------|------|----------------------|------|
| Afrikaans            | 0436 | Icelandic            | 040F |
| Albanian             | 041C | Indonesian           | 0421 |

|                               |      |                              |      |
|-------------------------------|------|------------------------------|------|
| Arabic - United Arab Emirates | 3801 | Italian - Italy              | 0410 |
| Arabic - Bahrain              | 3C01 | Italian - Switzerland        | 0810 |
| Arabic - Algeria              | 1401 | Japanese                     | 0411 |
| Arabic - Egypt                | 0C01 | Korean                       | 0412 |
| Arabic - Iraq                 | 0801 | Latvian                      | 0426 |
| Arabic - Jordan               | 2C01 | Lithuanian                   | 0427 |
| Arabic - Kuwait               | 3401 | Macedonian (FYROM)           | 042F |
| Arabic - Lebanon              | 3001 | Malay - Malaysia             | 043E |
| Arabic - Libya                | 1001 | Malay – Brunei               | 083E |
| Arabic - Morocco              | 1801 | Maltese                      | 043A |
| Arabic - Oman                 | 2001 | Marathi                      | 044E |
| Arabic - Qatar                | 4001 | Norwegian - Bokml            | 0414 |
| Arabic - Saudi Arabia         | 0401 | Norwegian - Nynorsk          | 0814 |
| Arabic - Syria                | 2801 | Polish                       | 0415 |
| Arabic - Tunisia              | 1C01 | Portuguese - Portugal        | 0816 |
| Arabic - Yemen                | 2401 | Portuguese - Brazil          | 0416 |
| Armenian                      | 042B | Raeto-Romance                | 0417 |
| Azeri - Latin                 | 042C | Romanian - Romania           | 0418 |
| Azeri - Cyrillic              | 082C | Romanian - Moldova           | 0818 |
| Basque                        | 042D | Russian                      | 0419 |
| Belarusian                    | 0423 | Russian - Moldova            | 0819 |
| Bulgarian                     | 0402 | Sanskrit                     | 044F |
| Catalan                       | 0403 | Serbian - Cyrillic           | 0C1A |
| Chinese - China               | 0804 | Serbian - Latin              | 081A |
| Chinese - Hong Kong SAR       | 0C04 | Setsuana                     | 0432 |
| Chinese - Macau SAR           | 1404 | Slovenian                    | 0424 |
| Chinese - Singapore           | 1004 | Slovak                       | 041B |
| Chinese - Taiwan              | 0404 | Sorbian                      | 042E |
| Croatian                      | 041A | Spanish - Spain              | 0C0A |
| Czech                         | 0405 | Spanish - Argentina          | 2C0A |
| Danish                        | 0406 | Spanish - Bolivia            | 400A |
| Dutch - Netherlands           | 0413 | Spanish - Chile              | 340A |
| Dutch - Belgium               | 0813 | Spanish - Colombia           | 240A |
| English - Australia           | 0C09 | Spanish - Costa Rica         | 140A |
| English - Belize              | 2809 | Spanish - Dominican Republic | 1C0A |
| English - Canada              | 1009 | Spanish - Ecuador            | 300A |
| English - Caribbean           | 2409 | Spanish - Guatemala          | 100A |

|                          |      |
|--------------------------|------|
| English - Ireland        | 1809 |
| English - Jamaica        | 2009 |
| English - New Zealand    | 1409 |
| English - Philippines    | 3409 |
| English - South Africa   | 1C09 |
| English - Trinidad       | 2C09 |
| English - United Kingdom | 0809 |
| English - United States  | 0409 |
| Estonian                 | 0425 |
| Farsi                    | 0429 |
| Finnish                  | 040B |
| Faroese                  | 0438 |
| French - France          | 040C |
| French - Belgium         | 080C |
| French - Canada          | 0C0C |
| French - Luxembourg      | 140C |
| French - Switzerland     | 100C |
| Gaelic - Ireland         | 083C |
| Gaelic - Scotland        | 043C |
| German - Germany         | 0407 |
| German - Austria         | 0C07 |
| German - Liechtenstein   | 1407 |
| German - Luxembourg      | 1007 |
| German - Switzerland     | 0807 |
| Greek                    | 0408 |
| Hebrew                   | 040D |
| Hindi                    | 0439 |
| Hungarian                | 040E |

|                       |      |
|-----------------------|------|
| Spanish - Honduras    | 480A |
| Spanish - Mexico      | 080A |
| Spanish - Nicaragua   | 4C0A |
| Spanish - Panama      | 180A |
| Spanish - Peru        | 280A |
| Spanish - Puerto Rico | 500A |
| Spanish - Paraguay    | 3C0A |
| Spanish - El Salvador | 440A |
| Spanish - Uruguay     | 380A |
| Spanish - Venezuela   | 200A |
| Southern Sotho        | 0430 |
| Swahili               | 0441 |
| Swedish - Sweden      | 041D |
| Swedish - Finland     | 081D |
| Tamil                 | 0449 |
| Tatar                 | 0444 |
| Thai                  | 041E |
| Turkish               | 041F |
| Tsonga                | 0431 |
| Ukrainian             | 0422 |
| Urdu                  | 0420 |
| Uzbek - Cyrillic      | 0843 |
| Uzbek - Latin         | 0443 |
| Vietnamese            | 042A |
| Xhosa                 | 0434 |
| Yiddish               | 043D |
| Zulu                  | 0435 |

**Note:** this list can be found on the MSDN Microsoft site:

<http://msdn.microsoft.com/library/default.asp?url=/library/en-us/script56/html/882ca1eb-81b6-4a73-839d-154c6440bf70.asp>

#### **A.10.5 – Displaying Text Session in Graphics Mode**

Previously Axel used the legacy method to display text sessions (telnet, 5250, 3270...) based on columns and rows (80x25, 132x25...) and a specific resolution.

We are changing the way we display text because:

- Many new TFT monitors no longer support the specific resolution required (720x400) - or if they do the characters are blurry and jittery
- Many monitors have a slight delay when changing session of different resolutions. Using graphics resolutions lets Windows and telnet sessions use the same resolution.
- Most new monitors are widescreen, and the legacy characters, designed for aspect ratio 4/3 can be distorted when 'stretched' on a wide screen monitor

The solution is to use graphics resolutions for text displays. This addresses the first two points above; the character issue is covered below.

The challenge is fitting characters designed for aspect ratio of 4/3 onto a 16/9 screen without creating distortion and keeping the characters ascetically acceptable.

To resolve this issue we offer two variables:

- Full screen or part screen (window).
- Options for character size and space between characters.

Below is the dialogue box showing the options – also see chapters 6.1.3, 7.1.2 and 8.1.4:

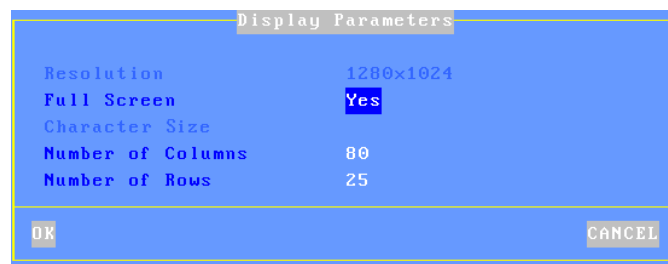

#### a) Full Screen Mode

To provide similar appearance to legacy screens a full screen mode is offered: the session is displayed on the entire screen and the character size is automatically adapted to the resolution and the number of lines/columns.

When the full screen mode is not selected the terminal calculates the optimal spacing between characters and a window is displayed:

- The background color is selected through the menu [Configuration]-[Sessions]-[Local Desktop]. (See Chapter 3.6.1)
- A grey-light frame surrounds the session.
- And the character size can be customized. (See next sub-section)

Example:

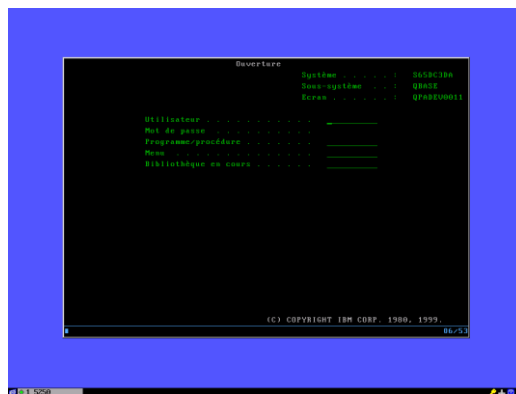

### b) Size and spacing of characters

The terminal has a single font (size 8x16 pixels), but two options:

- **Inserting spaces around character** (horizontal and vertical) to 'pad' the character

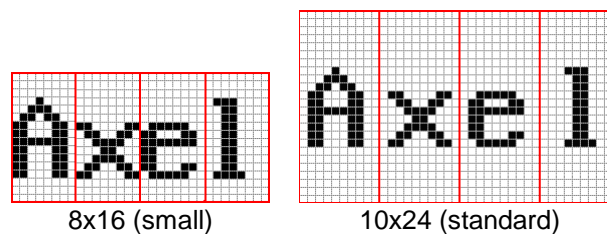

- **Doubling the size of the character** – each pixel mapped to 4 pixels



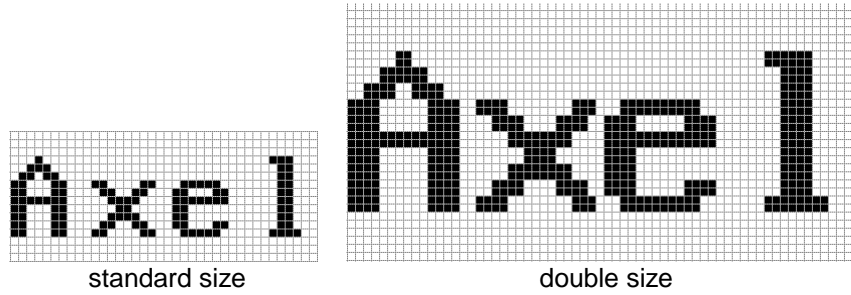

### ***c) Information about Current Session***

The <Ctrl><Alt><I> keystroke allows an information box to be displayed.

For example:

```
Server IP Address      192.168.1.180
Emulation              IBM5250
Resolution             1280x1024 60hz
Screen Size            80x24
Character Size         10x22

                        Press any key
```

## A.11 - HARDWARE AND FIRMWARE INFORMATION

To obtain the terminal's firmware and hardware revisions, use one of the following:

1. Use the AxRM utility - "Get Terminal Information" command,
2. Enter the AX3000 **interactive set-up**, and select '?',
3. Get the AX3000 set-up by issuing the **setup\_get** remote command (the revision is included in the text file banner):  
Example: rsh axname setup\_get > file
4. Use the following **ax\_version** remote command to get the revision directly:  
Example: rsh axname ax\_version

### A.11.1 - Hardware Information

The AX3000 hardware information is **FKx-BVyyy**:

- **FKx** is the circuit board code (FK stands for Flash Key)
- **BVyyy** is the boot code version (the boot code is the non-erasable part of the flash memory)

There are currently five different generations of hardware in the field:

- FK3: former production hardware of models 55, 55E and 56
- FK5: former production hardware of models 55, 55E and 56
- FK11: former production hardware of models 55, 55E and 56
- FK7: former production hardware of models 65
- FK13: former production hardware of models 65 and 65E
- FK14: former production hardware of models 65/65E (PS/2 mouse)
- FK15: current production hardware of models 60/60E
- FK16: former production hardware of models 75/75B/75E
- FK17: former production hardware of models 65B (10/100BaseT)
- FK18: former production hardware of models 75C
- FK19: former production hardware of models 75C
- FK20: former production hardware of models 65C
- FK30: former production hardware of models 70W
- FK31: current production hardware of models 70W
- FK35: former production hardware of models 70F
- FK36: current production hardware of models 70F
- FK40: former production hardware of models 75C
- FK41: current production hardware of models 75D

- FK45: current production hardware of models 65C
- FK51: current production hardware of models 85
- FK55: current production hardware of models 80F

**Note:** the correct firmware file must be downloaded for your AX3000 hardware. Example: if FK14 firmware file is downloaded into FK11 hardware, the download process will fail.

### **A.11.2 - Firmware Information**

The firmware version is **FCT.NA.yywwi:STD**

- **FCT** is the AX3000 operating mode (always TCP)
- **NA** is the firmware nationality (code is ISO compliant). The main nationalities are:
  - XX: International (except for the following countries)
  - BR: Brazil
  - CZ: Czechoslovakia
  - DK: Denmark
  - EE: Estonia
  - FI: Finland
  - FR: France
  - GR: Greece
  - IS: Iceland
  - PL: Poland
  - PT: Portugal
  - RU: Russia
  - SI: Slovenia
  - SK: Slovakia
  - TR: Turkey
- **yywwi** is the year and the week number of the firmware creation following by an alphabetical index (for instance: 0826c).
- **STD** stands for 'Standard'. In event of firmware option additional codes follow: **MSC** (Mass Storage Class), **SCA** (SmartCard), **TXT** (support of the legacy text mode)....

**Note:** three parameters depend on the firmware nationality:

- The set-up message nationality (FR: French messages, other: English messages),

- The possible presence of a national keyboard and associated character set. For instance, the Turkish environment (keyboards and character set) is only available with the 'TR' firmware.
- The default keyboard nationality (FR: France, XX: North American, TR: Turkey, etc).

## PERSONAL NOTES

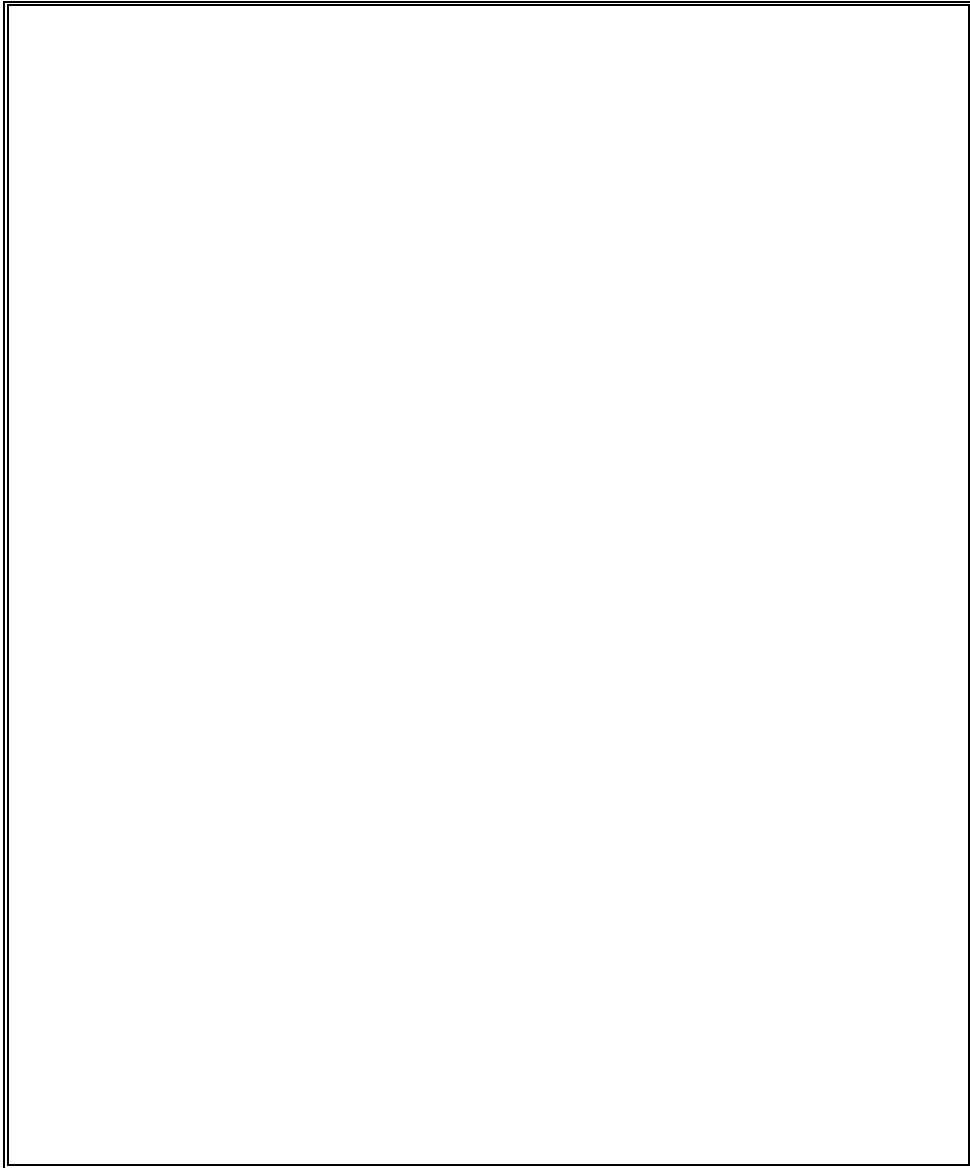
A large, empty rectangular box with a thin black border, intended for writing personal notes. The box is centered on the page and occupies most of the lower half of the document.

AXEL

14 Avenue du Québec  
Bât. K2 EVOLIC - BP 728  
91962 Courtabœuf cedex - FRANCE  
Tel.: 33 1.69.28.27.27 - Fax: 33 1.69.28.82.04 - Email: [info@axel.com](mailto:info@axel.com)